

## Model Examinations

## Model 1

Answer the following questions :

**1 Choose the correct answer :**

- (1) If the longest chord in a circle is 7 cm. , then the circumference of the circle is ..... cm. ( $\pi = \frac{22}{7}$ ) (3.5 or 7 or 22 or 44)
- (2) Twice the number  $x$  subtracted 3 from it = .....  
( $x - 3$  or  $2x + 3$  or  $2x - 3$  or  $3 - 2x$ )
- (3) If  $X = \{x : x \in \mathbb{N}, 2 \leq x \leq 3\}$  , then  $X =$  .....  
( $\{3, 2\}$  or  $\{3\}$  or  $\{2\}$  or  $\emptyset$ )
- (4)  $(49 \div 7)$  .....  $\mathbb{N}$  ( $\subset$  or  $\in$  or  $\not\subset$  or  $\notin$ )
- (5) The number of symmetrical axis of rhombus is .....  
(0 or 1 or 2 or 4)
- (6) The area of a square whose diagonal length is 8 cm. = .....  $\text{cm}^2$ .  
(44 or 36 or 50 or 32)
- (7) If  $x$  is an odd number , then  $x + 2$  is .....  
(even or odd or prime or otherwise)
- (8) The ordered pair  $(2, 5) = (2x, 5)$  , then  $x$  is .....  
(5 or 3 or 2 or 1)
- (9) The multiplicative neutral element in  $\mathbb{N}$  is .....  
(0 or 1 or 2 or 3)
- (10) On the coordinate plane :  $M(5, 1)$  ,  $N(5, 6)$   
, then  $MN =$  ..... length unit. (2 or 5 or 6 or 8)
- (11) The opposite geometric transformation is .....   
(rotation or translation or reflection)
- (12) The set of even numbers  $(E) \cap$  the set of prime number  $(P) =$  .....  
( $P$  or  $\{0\}$  or  $\mathbb{N}$  or  $\{2\}$ ) :



## Final Examinations

- (13) If the side length of a square is  $x$  and its perimeter is  $P$ , then  $P = \dots\dots\dots$   
 (  $4x$  or  $x+4$  or  $x-4$  or  $4-x$  )
- (14)  $(8 \times 3) \times 5 = \dots\dots\dots \times (3 \times 5)$  (  $3$  or  $5$  or  $8$  or  $35$  )

## 2 Complete each of the following :

- (15) 1 , 4 , 8 , 13 ,  $\dots\dots\dots$  ,  $\dots\dots\dots$  (in the same pattern)
- (16) The sum of two numbers is 35 , one of them is  $x$  , then the other is  $\dots\dots\dots$
- (17) The base length of a triangle is 8 cm. and its height is 5 cm. , then its area =  $\dots\dots\dots$   $\text{cm}^2$
- (18) The smallest counting number is  $\dots\dots\dots$
- (19)  $32 + (59 + \dots\dots\dots) = (32 + 68) + \dots\dots\dots$
- (20) The area of rhombus whose diagonals are 10 cm. and 20 cm. is  $\dots\dots\dots$   $\text{cm}^2$

## 3 Answer the following :

- (21) By using the properties of multiplication , find the value of :  $4 \times 31 \times 25$   
 $\dots\dots\dots$
- (22) In the cartesian coordinates determine the points  
 A (8 , 5) , B (8 , 2) , C (5 , 2) , D (5 , 7)  
 , then draw the figure ABCD and draw its image by reflection in  $\overleftrightarrow{CD}$

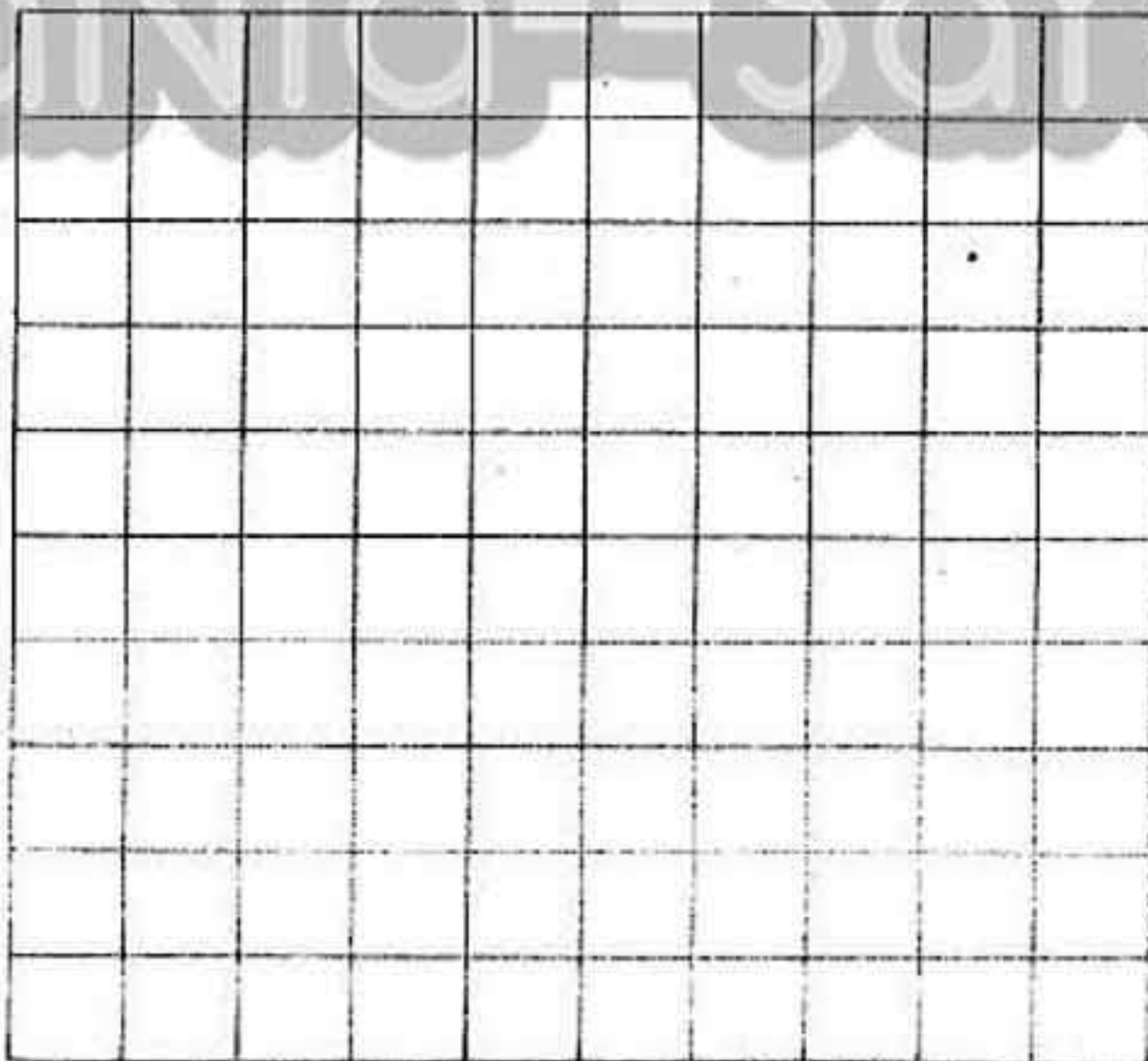



(23) Solve in  $\mathbb{N}$  the equation :  $3x + 5 = 17$

.....

(24) Calculate the perimeter of opposite figure :

$$\left(\pi = \frac{22}{7}\right)$$

.....

.....

.....

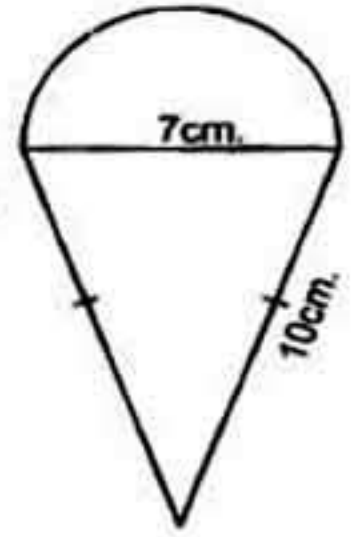

(25) If  $a = 3$  and  $b = 4$  , find the numerical value of :  $(b - a) (b + a)$

.....

(26) If the age of a man now is  $x$  years , find :

[a] The age of the man after 7 years .....

[b] The age of the man since 5 years .....

(27) A parallelogram has a base of length 14 m. and a corresponding height 9 m. Find its area.

.....

(28) If the number  $x$  exceeds twice the number  $y$  by 7 , write down the mathematical relation which relates  $x$  by  $y$

.....

(29) Using the properties of commutative and associative in  $\mathbb{N}$  to find the result of the following :

$$156 + 871 + 344 + 129 \text{ (Write the used property)}$$

.....

(30) The following table shows the marks of 50 pupils in mathematics exam in a month :

The sets	10 -	20 -	30 -	40 -	The total
The frequency	10	12	18	10	50



## Final Examinations

Represent the data by histogram and frequency polygon.

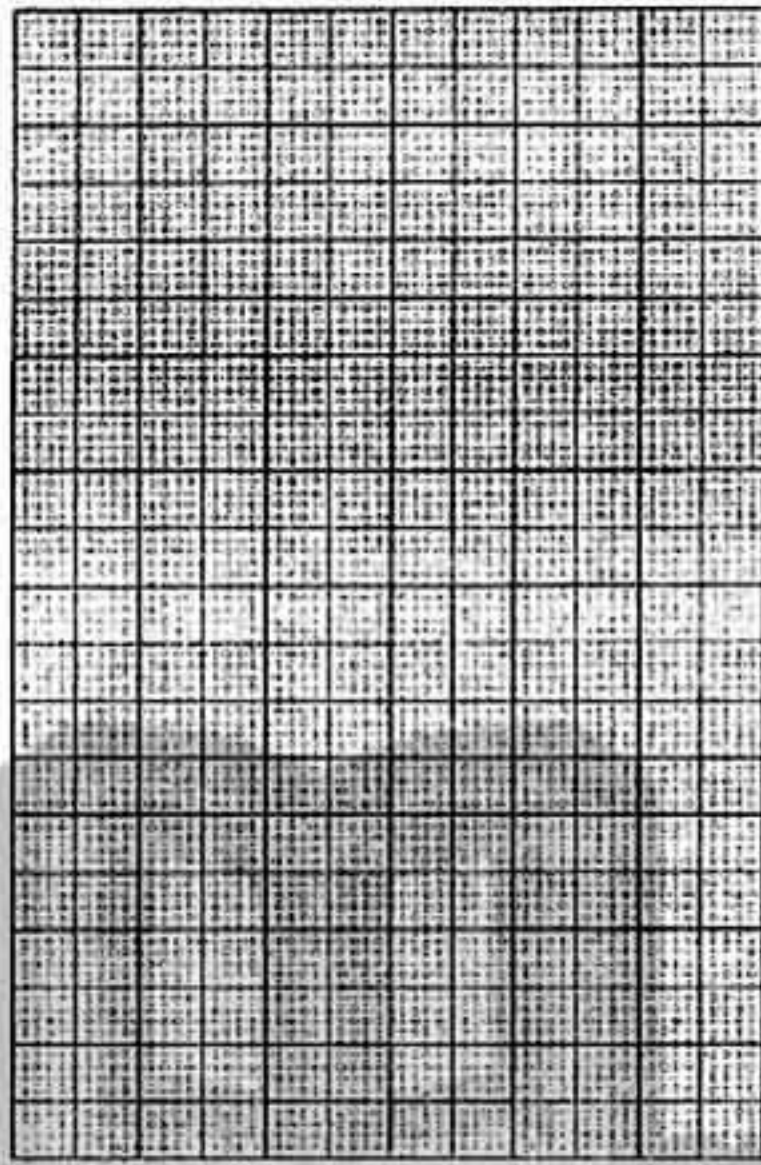

Model

2

Answer the following questions :

**1** Choose the correct answer :

- (1) The square whose perimeter is 16 cm. , its area = ..... cm<sup>2</sup>  
( 4 or 16 or 8 or 7 )
- (2) The sum of two numbers  $x$  and  $y$  is 10 , then  $y =$  .....  
(  $10 - x$  or  $x - 10$  or  $10x$  or  $\frac{10}{x}$  )
- (3) The number of symmetry axes of a rectangle is .....  
( 0 or 1 or 2 or 3 )
- (4)  $3 \times (2 + 10) =$  ..... ( 30 or 36 or 40 or 13 )
- (5) If  $7y = 84$  , then  $\frac{1}{2}y =$  ..... ( 6 or 12 or 21 or 42 )
- (6) 1 , 3 , 9 , 27 , ..... (in the same pattern)  
( 32 or 64 or 37 or 81 )
- (7) If  $O$  is the set of odd numbers , then  $O$  .....  $\mathbb{N}$   
(  $\in$  or  $\notin$  or  $\subset$  or  $\not\subset$  )



- ( 8 ) The rectangle whose length 7 cm. and width 3 cm. , its perimeter  
= ..... cm. ( 21 or 10 or 20 or 13 )
- ( 9 ) The additive identity element in  $\mathbb{N}$  is .....  
( 0 or 1 or 2 or 3 )
- (10)  $32 \times 53 + 32 \times \dots = 32 \times 100$  ( 53 or 47 or 37 or 23 )
- (11) The area of parallelogram = .....  
(  $b + h$  or  $b - h$  or  $b \times h$  or  $\frac{b}{h}$  )
- (12) The area of a rhombus equals  $24 \text{ cm}^2$  and the length of one  
of its diagonals is 8 cm. , then the length of the other diagonal  
= ..... cm. ( 3 or 6 or 8 or 12 )
- (13) The difference between three times a number and two is .....  
(  $3x + 2$  or  $3x - 2$  or  $2 \times 3x$  or  $\frac{3x}{2}$  )
- (14)  $(7 \times 3 - 3 \times 7) \dots \mathbb{N}$  (  $\in$  or  $\notin$  or  $\subset$  or  $\not\subset$  )

**2 Complete each of the following :**

- (15) If A (3 , 4) , B (5 , 2) , then the coordinate of the midpoint of  $\overline{AB}$   
is (..... , .....)
- (16) The opposite geometric transformation  is .....
- (17) If the perimeter of an equilateral triangle is 18 cm. and its area  
is  $15 \text{ cm}^2$  , then its height is ..... cm.
- (18) The diameter length of a circle whose circumference is 88 cm.  
= ..... cm. ( $\pi = \frac{22}{7}$ )
- (19) An odd number  $\times$  an even number = ..... number.
- (20) The isosceles trapezium has ..... axis of symmetry.

**3 Answer the following :**

- (21) Solve the equations in  $\mathbb{N}$  :

[a]  $2x - 5 = 3$

[b]  $a + 7 = 20$

.....  
.....



## Final Examinations

(22) Which is greater in area ?

A square with its diagonal length 12 cm. or a rhombus with the length of its diagonals are 15 cm. and 10 cm.

.....

.....

(23) On the coordinate plane draw  $\Delta ABC$  where  $A(2, 1)$  ,  $B(5, 1)$  ,  $C(5, 5)$  , then draw the image of  $\Delta ABC$  by reflection in  $\vec{BC}$

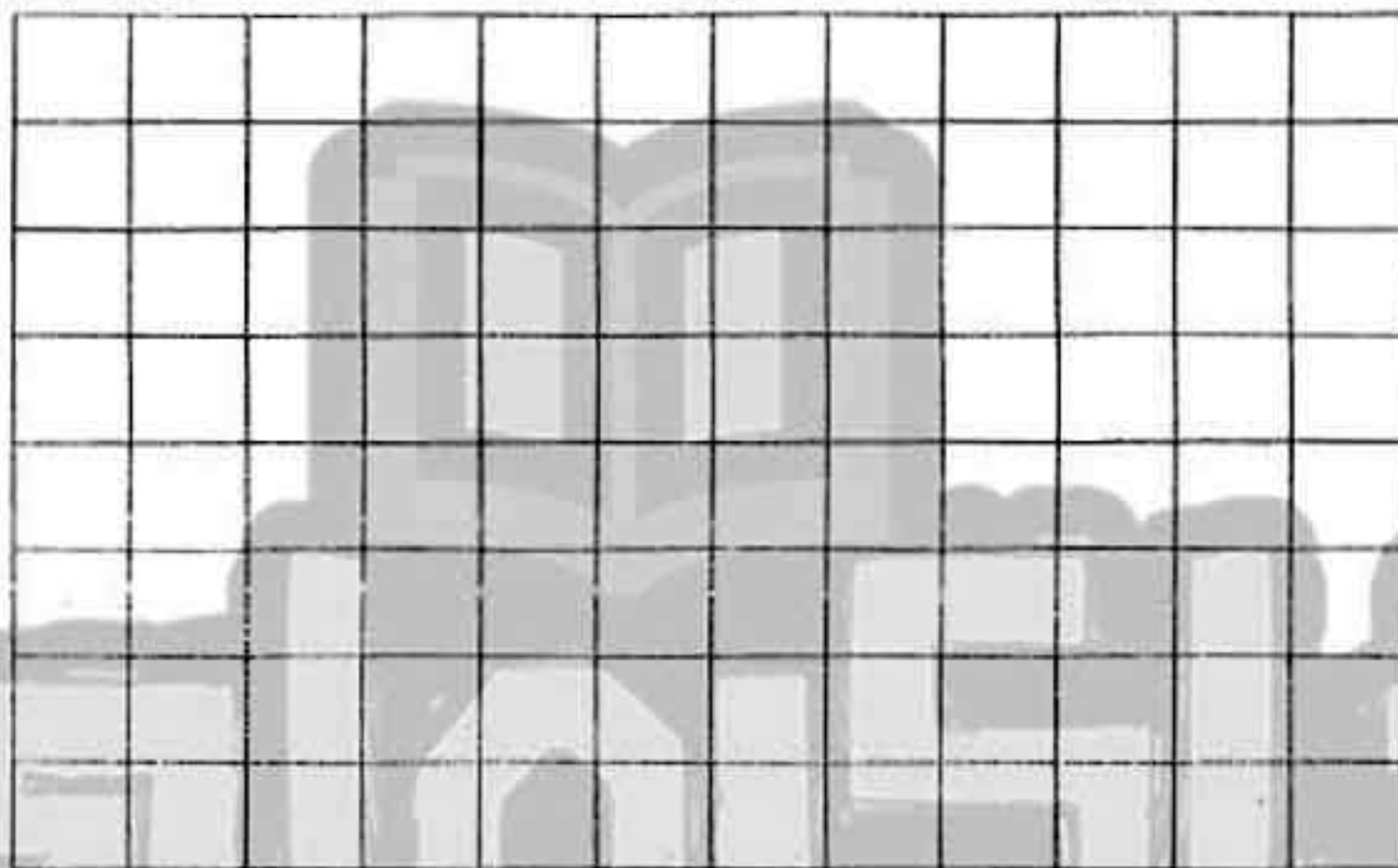

(24) Using the properties of addition in  $\mathbb{N}$  , find :  $55 + 36 + 45 + 64$

.....

(25) Find the perimeter of the figure where  $AB = 21$  m. and  $AD = 50$  m.

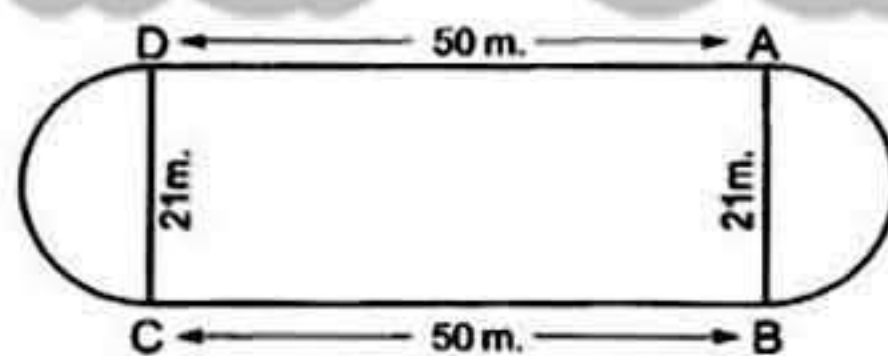

$$\left(\pi = \frac{22}{7}\right)$$

.....

.....

(26) Use the properties to find the result :  $8 \times 47 \times 125$

.....

(27) If  $a = 3$  ,  $b = 4$  ,  $c = 0$  , find the value of :  $2 \times a + 5 \times b - c$

.....



(28) Use the distribution property to find :  $37 \times 46 + 37 \times 54$

.....

(29) If  $X = \{2, 3, 4, 5\}$  and  $Y$  is the set of factors of 6, then find the following :

[a]  $X \cap Y$

[b]  $X \cup Y$

.....

(30) The following table shows the recorded temperatures in 40 cities on a day :

Temperature	20 -	22 -	24 -	26 -	28 -	Total
No. of cities	7	9	11	8	5	40

Represent these data by a histogram.

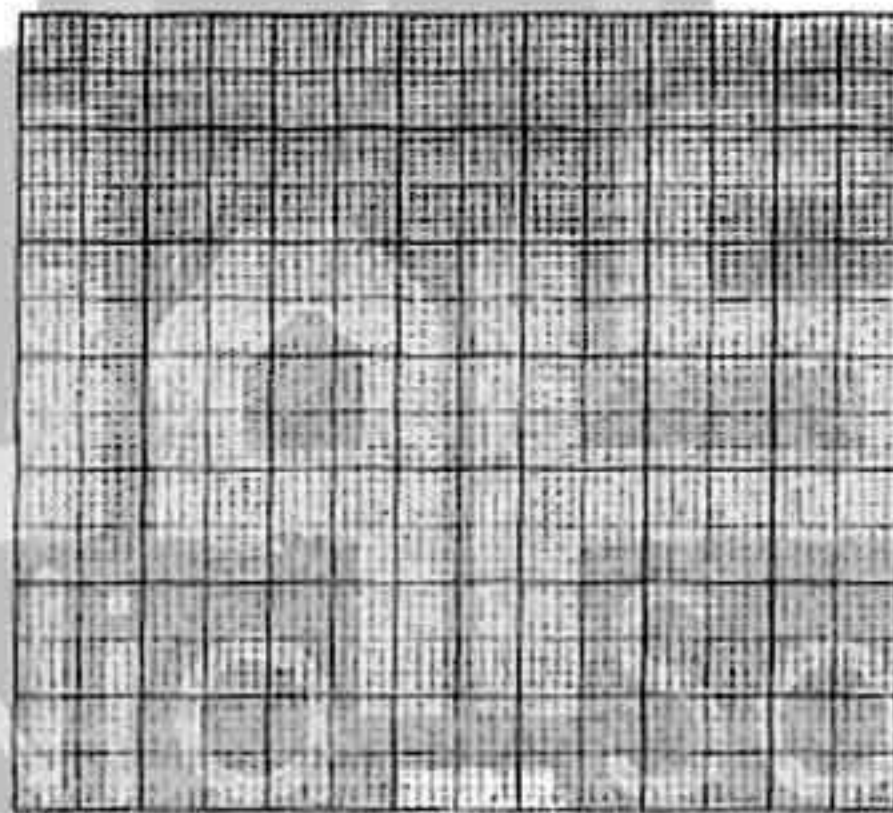

Model

3

Answer the following questions :

تابع جديد زاكروولي على موقعنا  
<https://www.zakrooly.com>

1 Choose the correct answer :

(1) If  $86 \times 15 = 86 \times a + 86 \times 10$ , then  $a =$  .....

(1 or 5 or 15 or 10)

(2)  $\{2, 3\} \cap \{1, 4\} =$  .....

( $\emptyset$  or  $\{1, 2, 3, 4\}$  or  $\{2, 3\}$  or  $\{1, 4\}$ )

(3) The area of the rhombus of diagonal length 7 cm. and 10 cm.

is .....  $\text{cm}^2$

(17 or 70 or 35 or 40)

43

هذا العمل خاص بموقع زاكروولي التعليمي ولا يسمح بتداوله على مواقع أخرى



## Final Examinations

- (4) If  $x$  is an odd number, then  $x + 3$  is ..... number.  
(odd or even or prime or otherwise)
- (5) The number of axes symmetry of square is .....  
(1 or 2 or 3 or 4)
- (6) If  $x + 8 = 15$ , then  $x =$  .....  
(3 or 7 or 6 or 5)
- (7) The diameter length of a circle whose circumference is 88 cm.  
equals ..... ( $\pi = \frac{22}{7}$ ) (28 or 14 or 7 or 21)
- (8) If three times a number subtracted from 15, then the expression  
that expresses this is .....  
( $3x + 15$  or  $15 - 3x$  or  $3x - 15$  or  $x - 15$ )
- (9) The square whose area is  $36 \text{ cm}^2$ , the length of its side = ..... cm.  
(5 or 6 or 3 or 7)
- (10) The multiplicative neutral element in  $\mathbb{N}$  – the additive neutral  
element in  $\mathbb{N} =$  ..... (0 or 1 or 2 or 3)
- (11) If  $x = 2$  and  $y = 3$ , then  $5xy =$  ..... (10 or 11 or 13 or 30)
- (12) The midpoint between (1, 5) and (5, 5) is .....  
( (5, 3) or (3, 5) or (5, 1) or (5, 5) )
- (13) The opposite geometric transformation  is .....  
(translation or reflection or rotation)
- (14) The perimeter of rectangle is 20 cm., and its width is  $x$  cm., then its  
length is ..... ( $10 - x$  or  $20 - x$  or  $x - 10$  or  $x - 20$ )

**2 Complete each of the following :**

- (15) 1, 1, 2, 3, 5, 8, ....., ....., ..... (in the same pattern)
- (16)  $75 + 89 = 89 + 75$  (..... property)
- (17) If  $945 = (x \times 100) + 45$ , then  $x =$  .....
- (18) The area of the parallelogram whose base length is 8 cm.  
and height 2.5 cm. is .....  $\text{cm}^2$
- (19) The symmetry axis divides the figure into two ..... halves.
- (20) If  $x \in \mathbb{N}$ ,  $2x = 8$ , then  $x =$  .....



**3 Answer the following :**

(21) Solve the equation in  $\mathbb{N}$  :  $5x - 2 = 8$

.....

(22) Use the properties of addition and multiplication to find the value of :

[a]  $45 \times 27 - 45 \times 27$

[b]  $28 + 36 + 72 + 64$

.....

(23) In 2-dimensional coordinate plane

locate the points A (3 , 1)

, B (5 , 1) , C (5 , 3) and D (3 , 3)

Name the figure ABCD

, then find its area.

.....

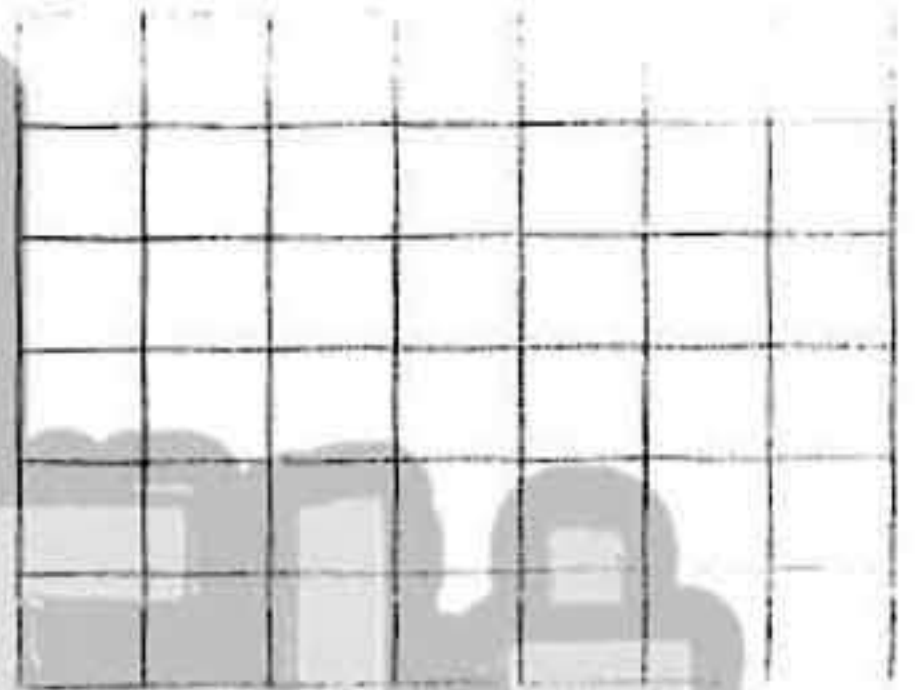
(24) If  $X = \{a : a \in \mathbb{N}, 1 \leq x < 5\}$  ,  $Y = \{4, 5, 6\}$  , find :

[a]  $X \cap Y$

[b]  $X \cup Y$

[c]  $X - Y$

.....

(25) In the cartesian coordinates plane , from the following figure :

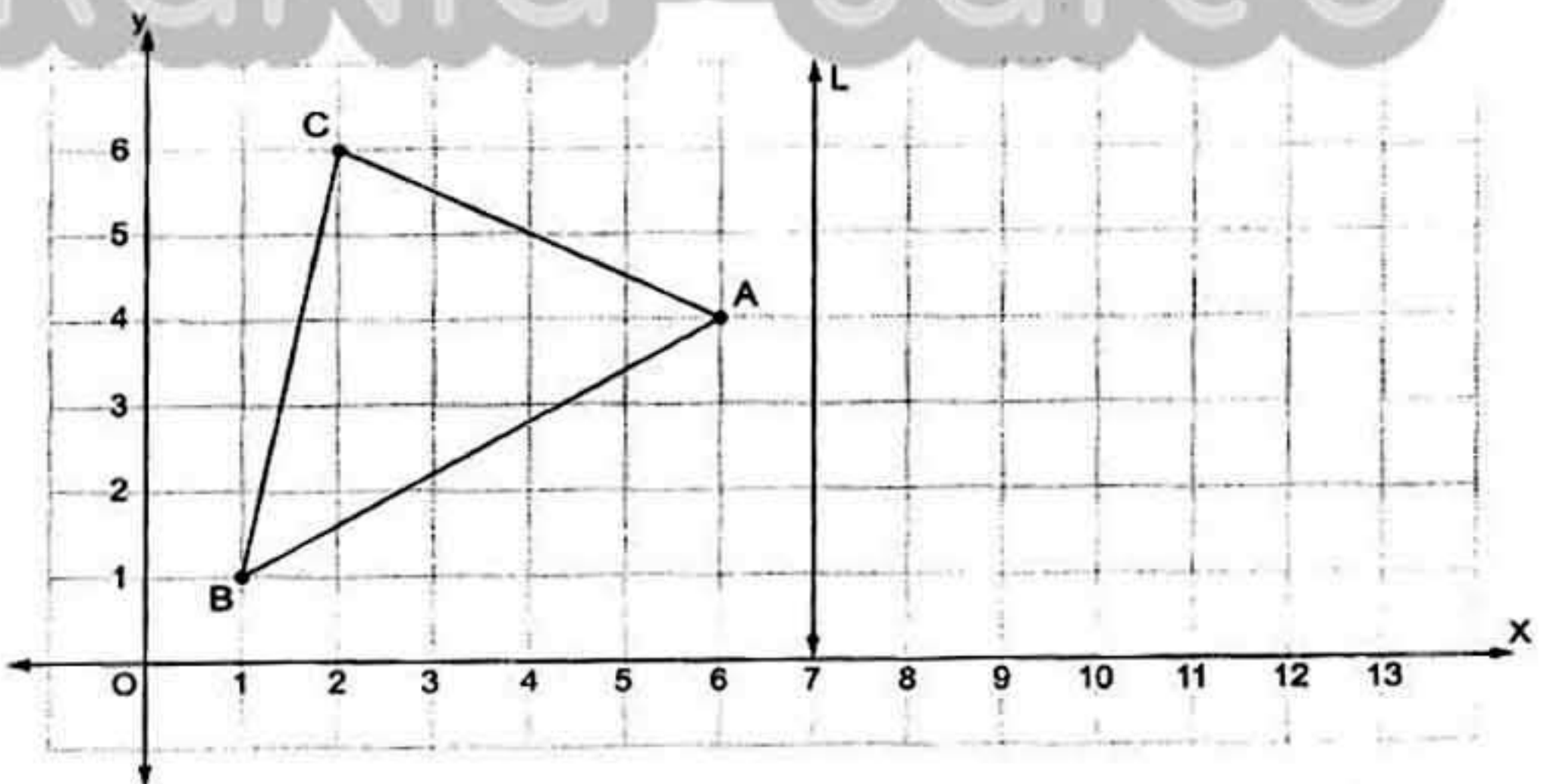



## Final Examinations

[a] Complete :

A (..... , .....), B (..... , .....) and C (..... , .....)

[b] If L is the axis of reflection of the  $\triangle ABC$ , draw  $\triangle A'B'C'$

the image of  $\triangle ABC$  by reflection in the straight line L

(26) In the opposite figure :

ABCD is a parallelogram in which

AB = 10 cm. , DE = 12 cm. , DF = 8 cm.

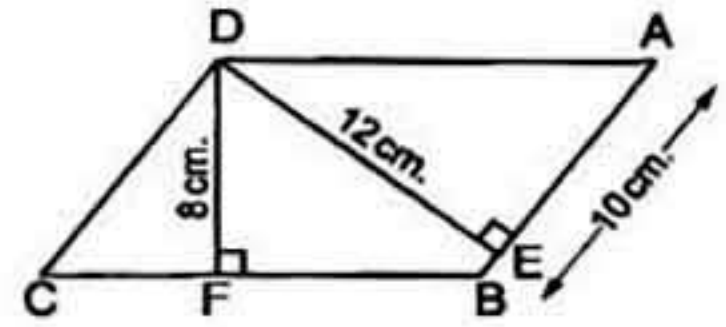

Find : [a] The area of the parallelogram ABCD

[b] The length of  $\overline{BC}$

.....

.....

(27) In the opposite figure :

Calculate the perimeter of the

figure where AM = 35 cm. ( $\pi = \frac{22}{7}$ )

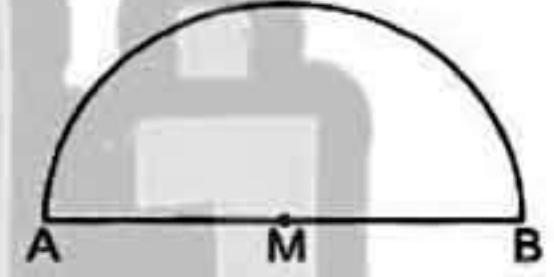

.....

(28) An employee spends his salary as following :

L.E. 200 for clothes.

L.E. 800 for food.

L.E. 400 for transportation and medicine.

L.E. 200 for renting.

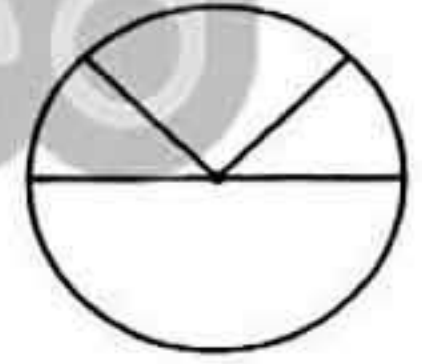

Graph that data on the opposite pie graph.

(29) Which is greater in area ?

Asquare whose diagonal is 10 cm. or a rhombus of area 80 cm<sup>2</sup>

.....

.....



(30) Represent the following data by a frequency ploygon :

Sets	10 -	20 -	30 -	40 -	Total
Frequency	10	12	18	10	50

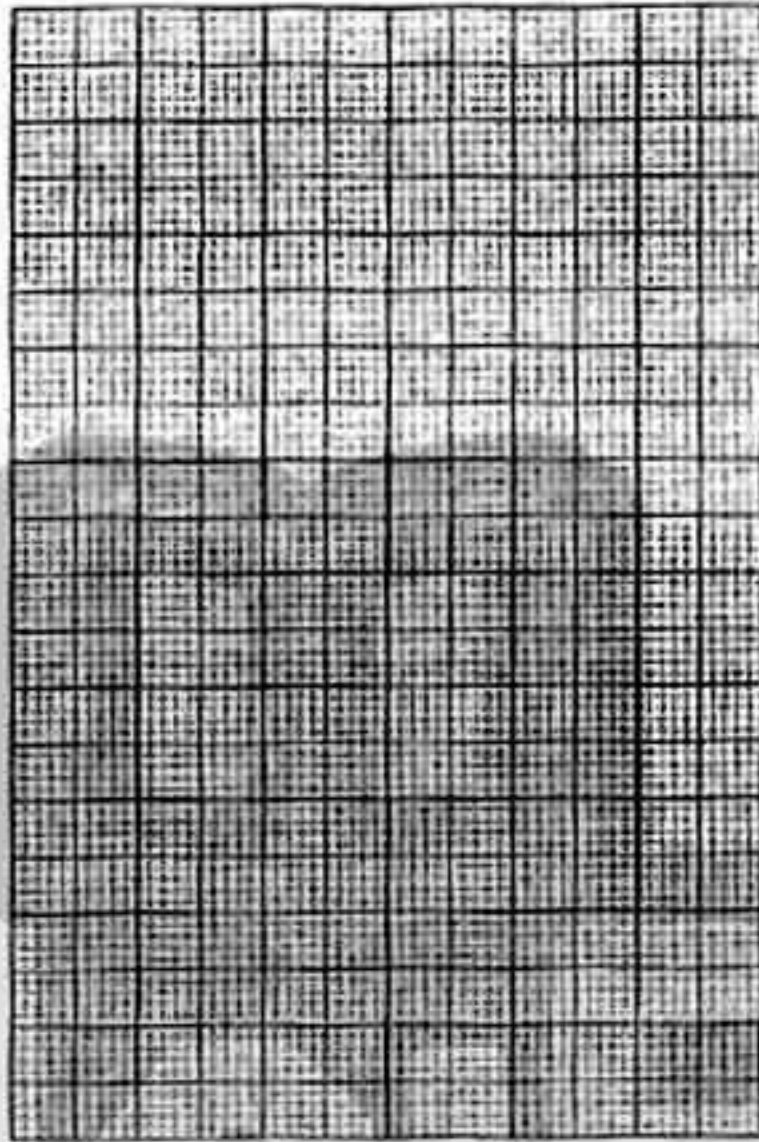

Model

4

Answer the following questions :

1 Choose the correct answer :

- (1) The next number in the pattern 5 , 35 , 65 , ..... is .....  
( 70 or 95 or 105 or 115 )
- (2) If  $X = \{x : x \in \mathbb{N} , x < 3\}$  , then  $X = \dots\dots\dots$   
(  $\{1, 2\}$  or  $\{2\}$  or  $\{0, 1, 2\}$  or  $\emptyset$  )
- (3) The number of axes of symmetry of the rhombus equals .....  
( zero or 1 or 2 or 4 )
- (4) The circumference of the circle its radius 5 cm. = .....  $\pi$  cm.  
( 10 or 5 or 20 or 4 )
- (5)  $53 \times 16 = 16 \times \dots\dots\dots$  ( 35 or 61 or 53 or 16 )
- (6) If  $10 = 2y$  , then the value of  $y$  is ..... ( 5 or 6 or 8 or 14 )



## Final Examinations

- (7) The multiplicative neutral element in  $\mathbb{N}$  is .....  
(0 or 1 or 2 or 3)
- (8) Subtracting 5 from double the number  $x =$  .....  
( $x - 5$  or  $2x - 5$  or  $5 - 2x$  or  $5x$ )
- (9) The area of rhombus whose diagonals are 6 cm. and 8 cm.  
= .....  $\text{cm}^2$  (48 or 14 or 24 or 100)
- (10)  $(49 \div 8) \dots \mathbb{N}$  ( $\subset$  or  $\not\subset$  or  $\in$  or  $\notin$ )
- (11) If  $x$  is an odd number, then  $x + 3$  is ..... number.  
(odd or even or prime or otherwise)
- (12) If  $x + 5 = 7$ ,  $x \in \mathbb{N}$ , then  $x =$  ..... (1 or 2 or 3 or 4)
- (13) The triangle whose base length is 5 cm. and the corresponding height of it is 8 cm., its area = .....  $\text{cm}^2$   
(13 or 20 or 26 or 40)
- (14) On the coordinate plane :  $M(1, 2)$ ,  $N(1, 8)$ , then  
 $MN =$  ..... length units. (2 or 5 or 6 or 8)

**2 Complete each of the following :**

- (15) Area of parallelogram = .....  $\times$  .....
- (16) If  $A$ ,  $B$  and  $C$  are natural numbers, then  $(A \times B) \times C = A \times (B \times C)$   
called ..... property.
- (17) The set of even numbers  $\cap$  the set of odd numbers = .....
- (18) The perimeter of the equilateral triangle whose side length is  $l$  cm.  
= ..... cm.
- (19) The set of prime numbers which are less than 17 is .....
- (20) The square whose perimeter is 32 cm., its area = .....  $\text{cm}^2$

**3 Answer the following :**

- (21) Find the perimeter of the opposite figure :

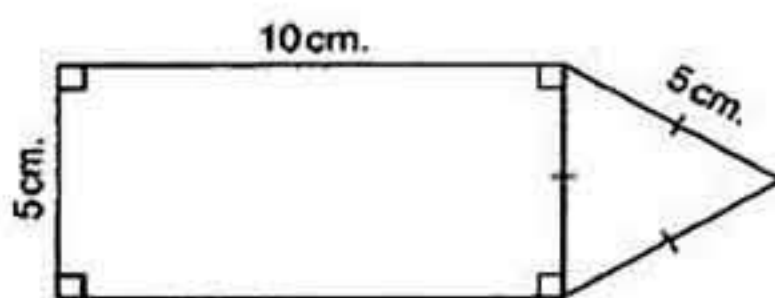



(22) In the cartesian coordinates plane , locate the points

A (2 , 2) , B (5 , 2) , C (5 , 6)

[a] Find the length of each of  $\overline{AB}$  and  $\overline{BC}$

[b] Draw the image of figure ABC by reflection in  $\overleftrightarrow{BC}$

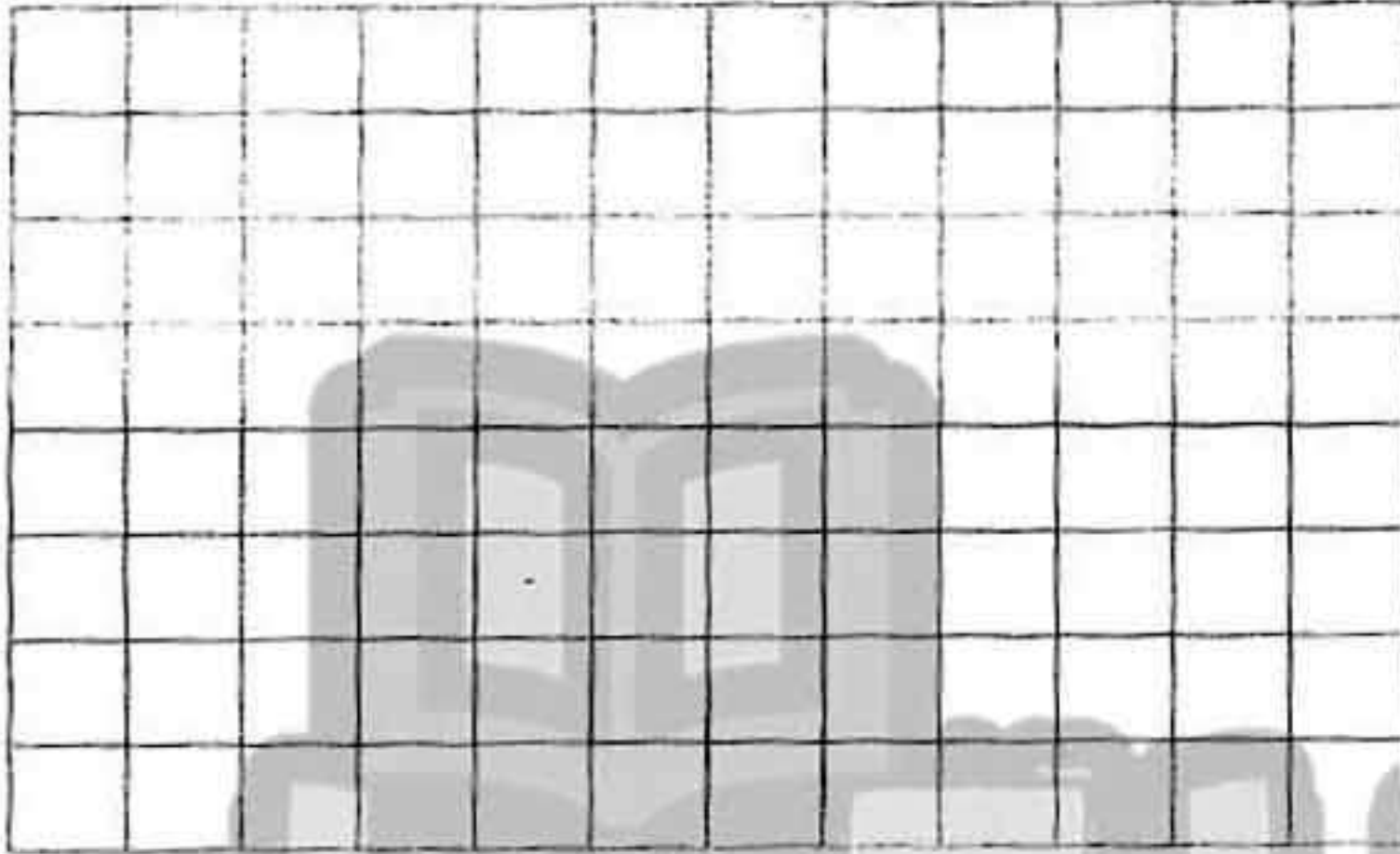

(23) Use the properties of the operations to find :

[a]  $872 + 199 + 128 + 801$

[b]  $56 \times 1001$

.....  
 .....

(24) Solve the equations :

[a]  $2x + 9 = 21$  ,  $x \in \mathbb{N}$

[b]  $x - 5 = 2$  ,  $x \in \mathbb{N}$

.....  
 .....

(25) If the number  $x$  exceeds twice the number  $y$  by 9

Write the mathematical relation between  $x$  and  $y$

.....

(26) Two circles the diameter of the first is 10 cm. and the diameter of the second is 15 cm. , find the difference between their circumferences.

$(\pi = 3.14)$

.....



## Final Examinations

(27) A square shaped piece of land with diagonal length 25 m. and a square shaped house with side length 15 m. has been built on it and the left part used as a garden , find the area of the garden.

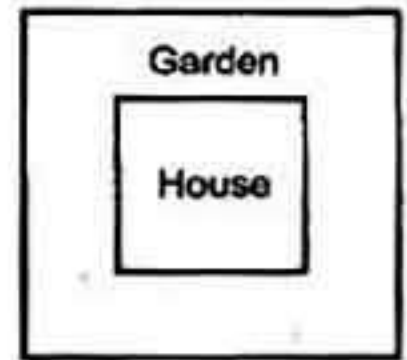

(28) Use the properties of commutative and associative in  $\mathbb{N}$  to find the result of :  $8 \times 43 \times 125$

(29) Solve the equation :  $x \times 3 + x \times 60 = 4 \times 63$

(30) The following table shows the frequency distribution of the number of work hours of 50 workers :

Sets	4 –	6 –	8 –	10 –	Total
Frequency	12	8	16	14	50

Draw the histogram which represents these data.

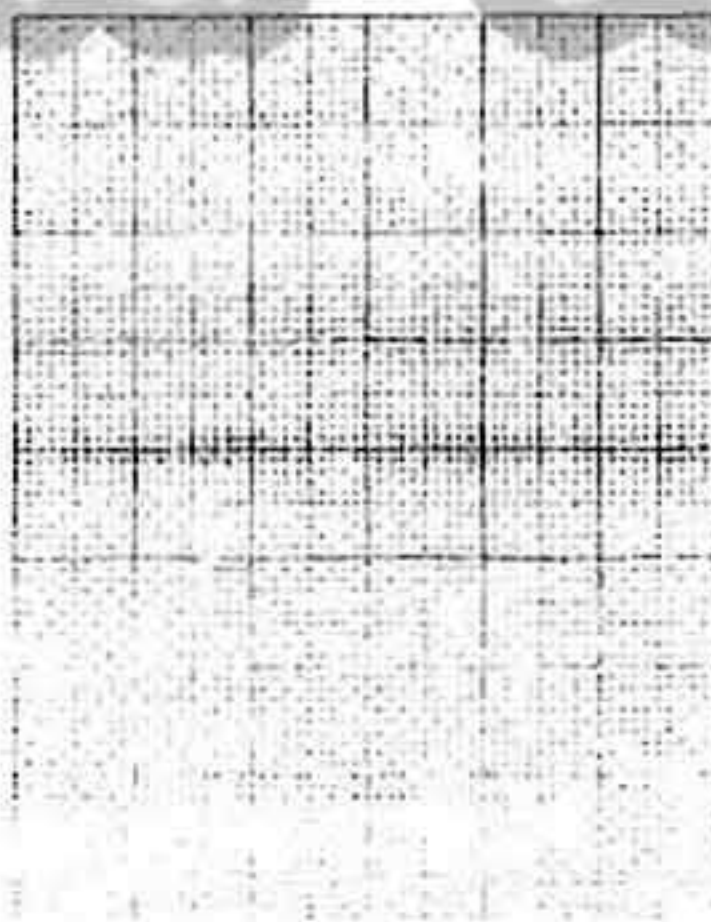

تابعنا على صفحتنا على الفيسبوك

[www.facebook.com/ZakroolySite](http://www.facebook.com/ZakroolySite)



## Model 5

Answer the following questions :

1 Choose the correct answer :

(1) If  $(x + 2) \times 7 = 7 \times 8$ , then  $x = \dots\dots\dots$  (6 or 7 or 8 or 56)

(2) If the difference between two numbers is 5 the smaller number is  $y$ , then the greater number is  $\dots\dots\dots$

(5y or 5 - y or y - 5 or y + 5)

(3) The isosceles triangle has  $\dots\dots\dots$  line(s) of symmetry.

(1 or 2 or 3 or 4)

(4) The shaded triangle is the image of the other triangle

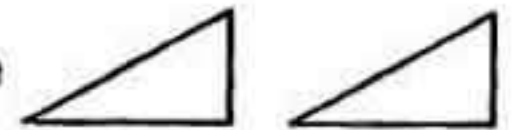

by a  $\dots\dots\dots$

(perimeter or translation or reflection or rotation)

(5) The length of diagonal of rhombus its area  $20 \text{ cm}^2$  and the length of the other diagonal is 8 cm. =  $\dots\dots\dots$  cm. (5 or 10 or 4 or 6)

(6)  $\frac{0}{7} \dots\dots\dots \mathbb{N}$  ( $\in$  or  $\notin$  or  $\subset$  or  $\not\subset$ )

(7) The area of a square whose diagonal length 6 cm. is  $\dots\dots\dots \text{ cm}^2$

(18 or 36 or 12 or 24)

(8) The additive neutral element in  $\mathbb{N}$  is  $\dots\dots\dots$  (0 or 1 or 2 or 3)

(9) If  $3x = 12$ , then  $x + 3 = \dots\dots\dots$  (4 or 6 or 7 or 10)

(10) The circumference of the circle =  $\dots\dots\dots$

(2dπ or 2π or πr or 2πr)

(11)  $5 \times (100 - \dots\dots\dots) = 5 \times 99$  (1 or 2 or 99 or 0)

(12) If E is the set of even numbers, then  $E \dots\dots\dots \mathbb{N}$

( $\in$  or  $\notin$  or  $\subset$  or  $\not\subset$ )

(13) If (5, 6), then y coordinate =  $\dots\dots\dots$  (1 or 6 or 11 or 5)

(14) If  $X = \{x : x \in \mathbb{N}, 3 < x < 4\}$ , then  $X = \dots\dots\dots$

( $\emptyset$  or {3, 4} or {3} or {4}).



## Final Examinations

**2 Complete each of the following :**

(15) 2 , 7 , 12 , 17 , ..... , ..... (in the same pattern)

(16) In the opposite figure :

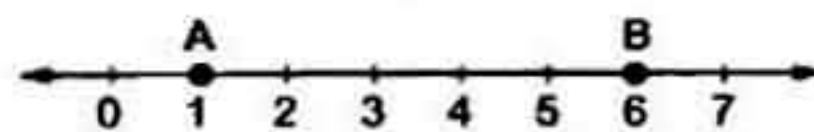
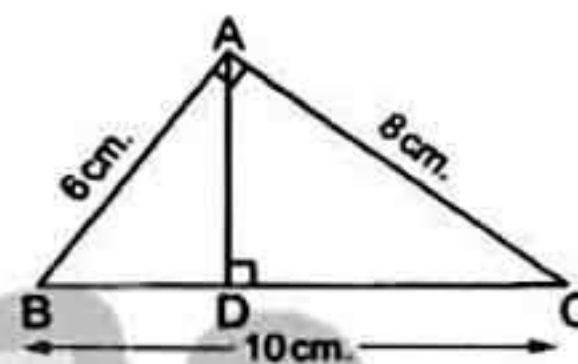
The length of  $\overline{AB}$  = ..... length units.(17) If the longest chord in a circle is 7 cm. , then the circumference of the circle is ..... cm. (where  $\pi = \frac{22}{7}$ )(18) Adding to the double of  $x$  is written as .....(19) The area of triangle = .....  $\times$  .....(20)  $\mathbb{N} - \{0\} = \dots\dots\dots$ **3 Answer the following :**(21) ABC is a right-angled triangle at A ,  
AB = 6 cm. , AC = 8 cm. and BC = 10 cm.Find : [a] The area of  $\triangle ABC$ [b] The length of  $\overline{AD}$ (22) Use the properties of addition to find :  $71 + 82 + 29 + 18$ 

(23) In the cartesian coordinate plane , from the following figure :

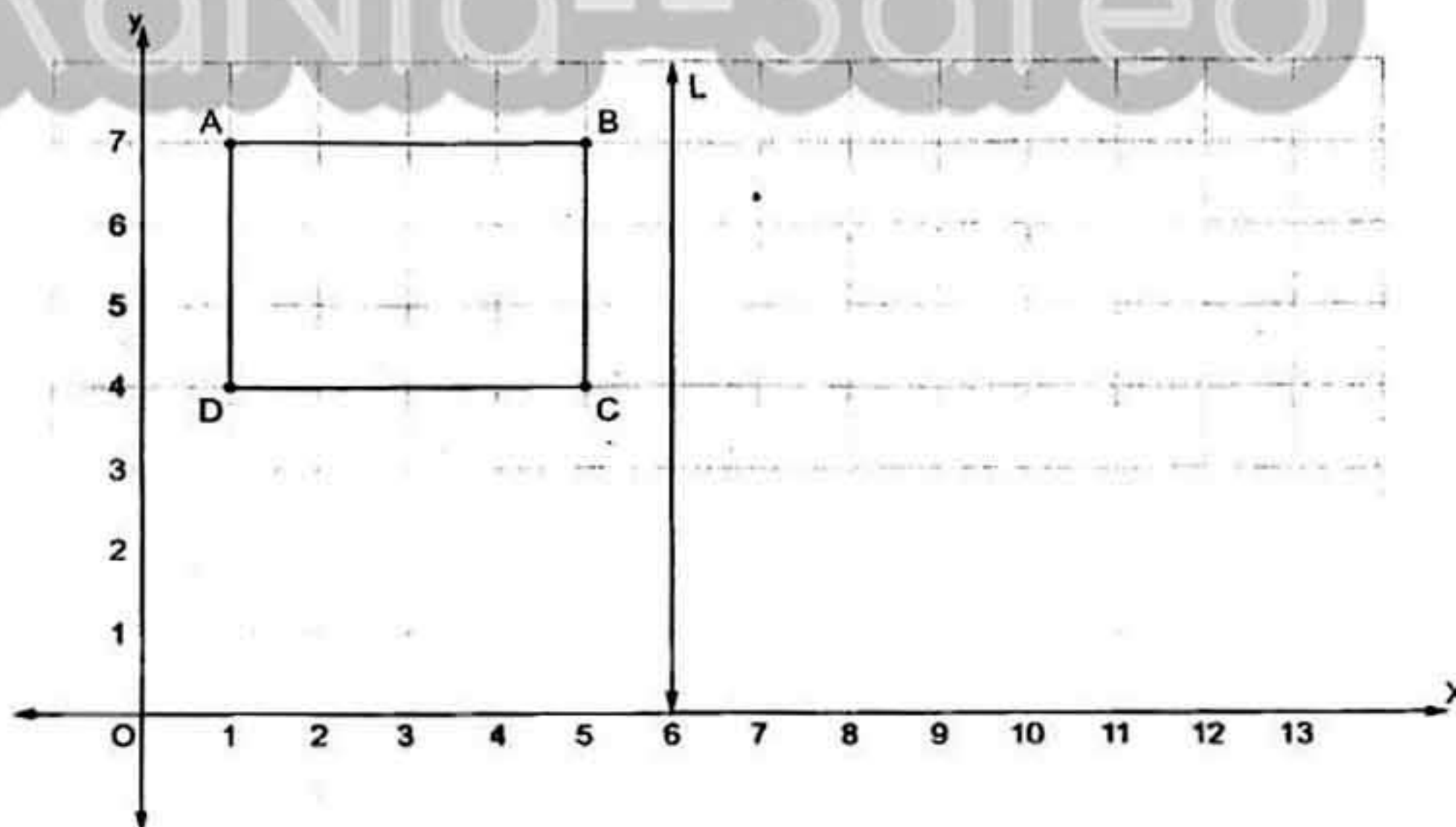



[a] Complete :

A (..... , .....) , B (..... , .....)

C (..... , .....) , D (..... , .....)

[b] If L is the axis of reflection of the figure ABCD , find the image of the figure by reflection in the straight line L , then complete :

$\hat{A}$  (..... , .....) ,  $\hat{B}$  (..... , .....)

$\hat{C}$  (..... , .....) ,  $\hat{D}$  (..... , .....)

(24) In the opposite figure :

The perimeter of the square ABCD = 56 cm. , find the perimeter of the whole figure.

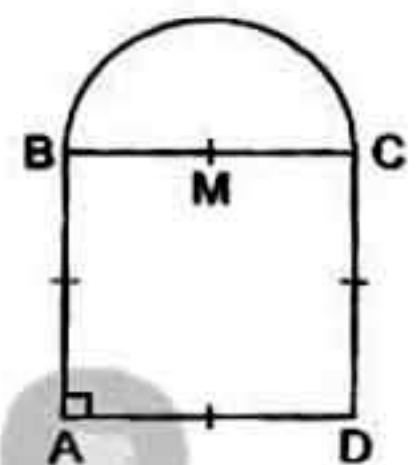

(25) Use the distribution property to find the value of :  $18 \times 99$

(26) Solve the equation :  $2x + 3 = 23$  where  $x \in \mathbb{N}$

(27) Calculate using commutative and associative properties :  $2 \times 347 \times 5$

(28) Find the height of the parallelogram with area  $48 \text{ cm}^2$  and its base is 8 cm. long.

(29) If  $x = 3$  ,  $y = 2$  and  $z = 5$  , find the following :

[a]  $x \times y + y \times z$

[b]  $(x - y) \times z$



## Final Examinations

(30) The opposite bar graph shows the number of pupils in each sport group in a school :

[a] What is the most popular game ?

.....

[b] What is the least popular game ?

.....

[c] What is the total number of pupils ?

.....

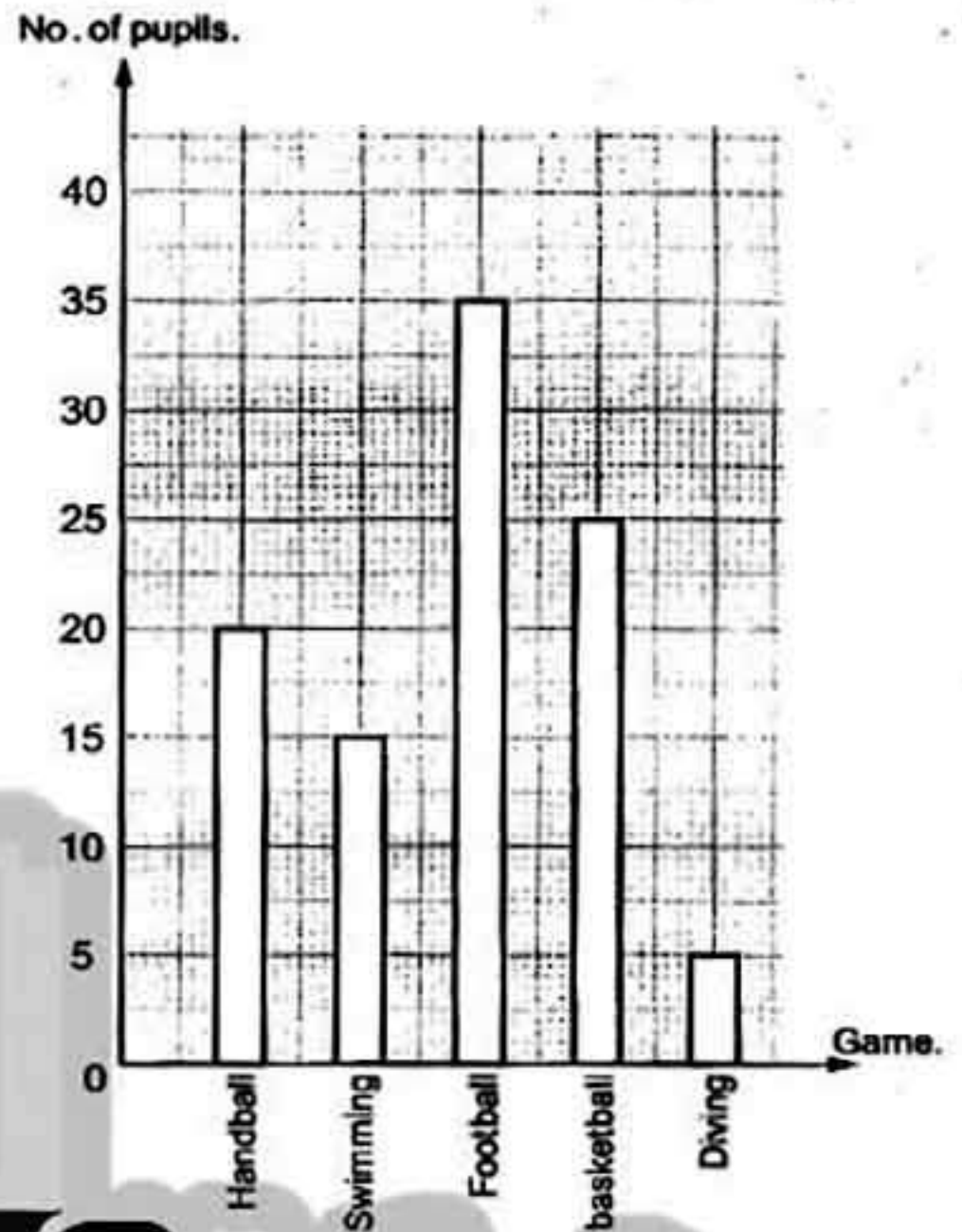

Model

6

Answer the following questions :

1 Choose the correct answer :

- (1) If the age of a man is  $x$  now , then his age after 7 years is .....  
(  $x+7$  or  $x-7$  or  $7x$  or  $7-x$  )
- (2) The square whose area is  $8 \text{ cm}^2$  , the length of its diagonal = ..... cm.  
( 32 or 4 or 8 or 16 )
- (3) The rhombus has ..... line(s) of symmetry.  
( zero or 1 or 2 or 4 )
- (4) The circumference of a circle with diameter length 14 cm.  
= .....  $\pi$  cm. ( 7 or 14 or 28 or 16 )
- (5) If  $3x = 15$  ,  $x \in \mathbb{N}$  , then  $x + 1 =$  ..... ( 3 or 4 or 5 or 6 )
- (6) The least prime number  $\times$  any prime number = ..... number.  
( odd or even or prime or otherwise )
- (7) If we multiply the number  $x$  by 7 , then we subtract from the result 3 , we shall get .....  
(  $7x+3$  or  $3x+7$  or  $7x-3$  or  $3-7x$  )



- (8) The length of the base of a triangle whose area is  $240 \text{ cm}^2$  and its height = 10 cm. is ..... cm. ( 12 or 24 or 48 or 2400 )
- (9) If  $X = \{x : x \in \mathbb{N}, 3 < x \leq 5\}$ , then  $X = \dots\dots\dots$   
( {4, 5} or {4} or {3, 4} or {5} )
- (10) The midpoint between (1, 2) and (7, 2) is .....  
( (3, 2) or (4, 2) or (2, 3) or (2, 4) )
- (11) ..... triangle has three sides are equal in length.  
( Obtuse or Scalene or Equilateral or Isosceles )
- (12)  $37 \times 100 - 37 \times \dots\dots\dots = 37 \times 15$  ( 115 or 75 or 85 or 63 )
- (13) If  $x = 2$  and  $y = 3$ , then  $5xy = \dots\dots\dots$  ( 10 or 11 or 13 or 30 )
- (14)  $213 + 57 = 57 + 213$  is called ..... property. ( commutative or closure or associative or additive identity element )

**2 Complete each of the following :**

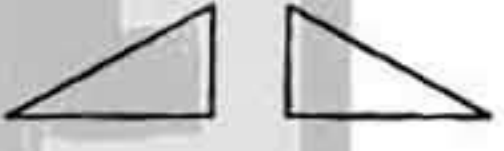
- (15) The opposite transformation is ..... 
- (16) 8, 11, 14, ..... (in the same pattern)
- (17)  $\{2, 3\} \cap \{1, 4\} = \dots\dots\dots$
- (18) The area of the parallelogram = ..... x .....
- (19)  $45 \times (37 + 63) = 45 \times \dots\dots\dots = \dots\dots\dots$
- (20) If we add 9 to four times of number  $z$ , then we get .....

**3 Answer the following :**

- (21) The opposite figure shows a football playground, find the distance around the figure (where  $\pi = \frac{22}{7}$ )

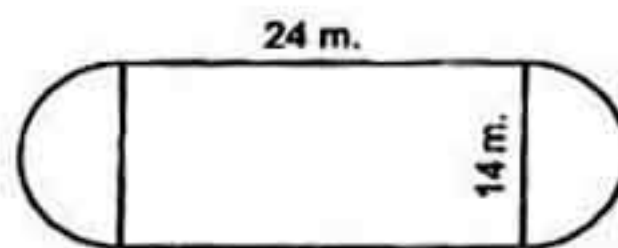



## Final Examinations

- (22) In a coordinate plane , draw the figure ABCD in which A (2 , 3) , B (2 , 5) , C (5 , 5) and D (5 , 2) , then draw its image by reflection across  $\overleftrightarrow{CD}$

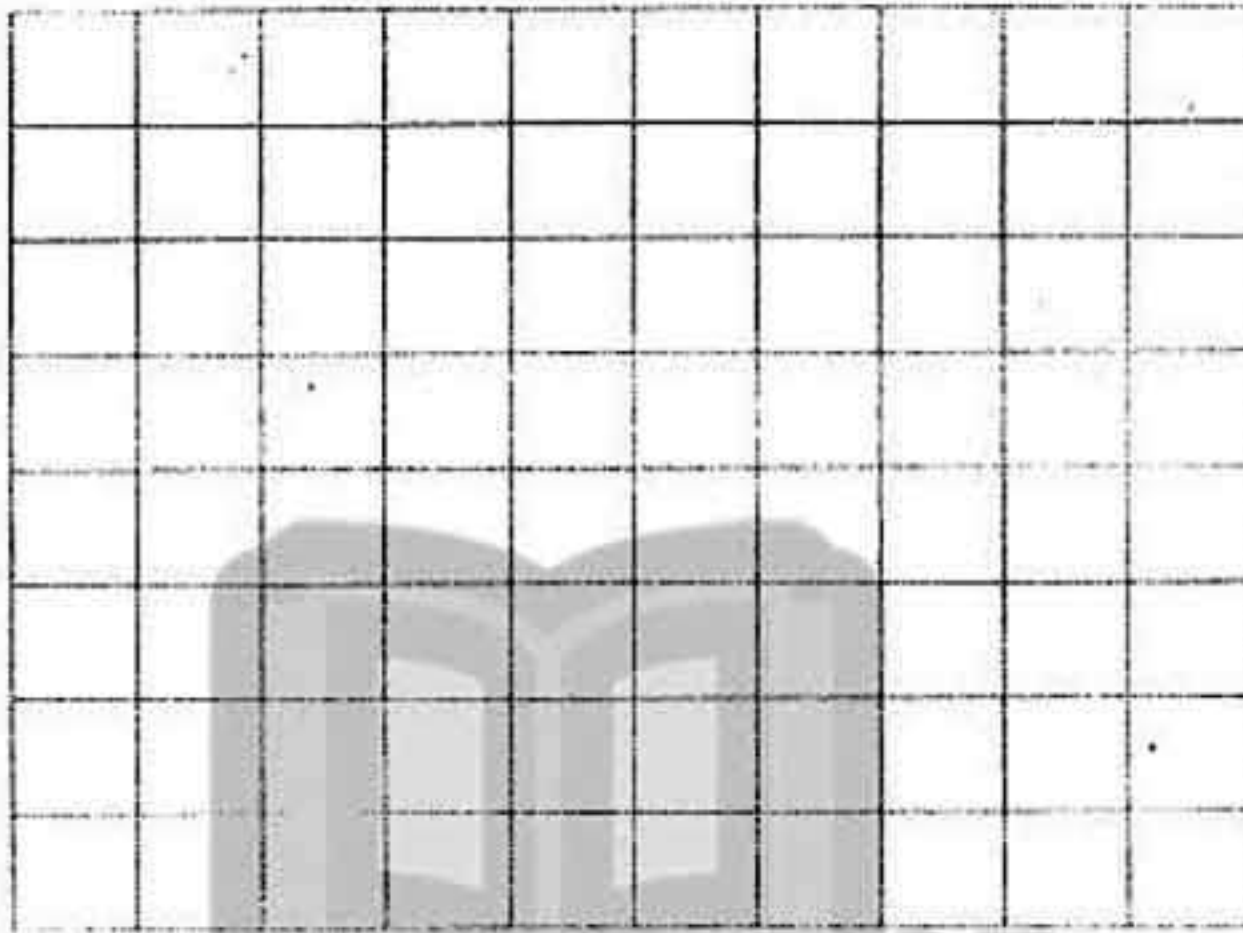

- (23) Use the properties of addition operation in  $\mathbb{N}$  to find the result of :  
 $72 + 89 + 28 + 11$

.....

- (24) Solve the following equation in  $\mathbb{N}$  :  $\frac{1}{7} x - 2 = 3$

.....

- (25) Find the area of a rhombus with diagonal length 6 cm. and 9 cm.

.....

- (26) Use the distributive property to find :  $26 \times 999$

.....

- (27) Noticing the opposite pie graph ,  
 a school has 1000 students :

- [a] What is the number of students  
 in the primary stage ?

.....

- [b] What is the number of students in the KG stage ?

.....

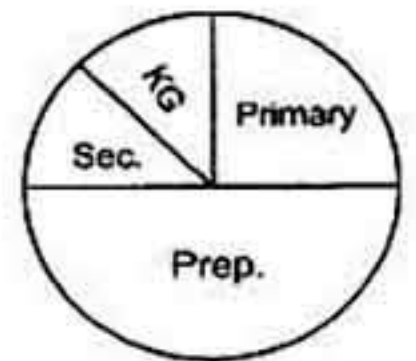



(28) Use the properties of multiplication to find :  $8 \times 69 \times 125$

.....

(29) In the opposite figure :

ABC is an isosceles triangle.

Find the perimeter of the triangle.

.....

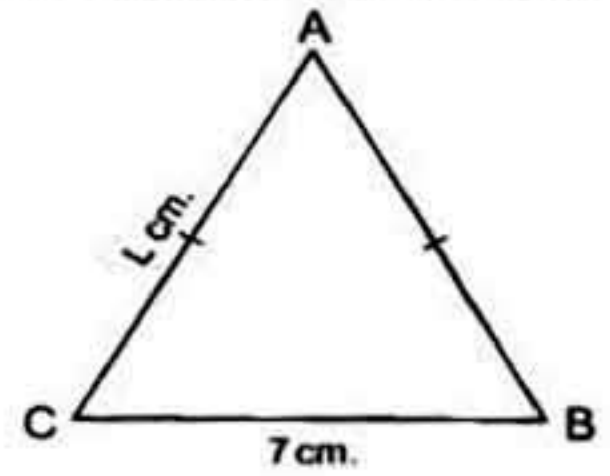

(30) The following table represents the marks of students in math exam :

Sets	10 -	20 -	30 -	40 -
Frequency	7	12	10	9

Draw the frequency polygon of these data.

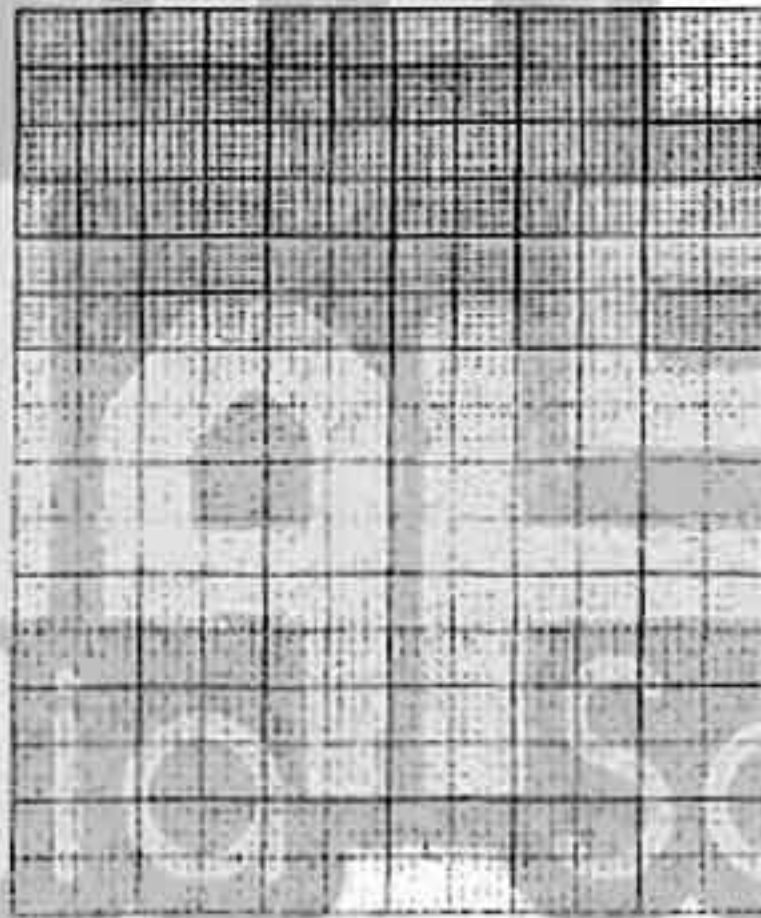

Model

7

Answer the following questions :

1 Choose the correct answer :

- (1) The number of axes of symmetry of rhombus equals .....  
( zero or 1 or 2 or 4 )
- (2) If  $7 \times 21 = 21 \times x$ , then  $x =$  ..... ( 7 or 3 or 21 or 147 )
- (3) Sama saved L.E.  $y$  and her father gave her L.E. 12, then she has  
L.E. ....  
(  $y - 12$  or  $12y$  or  $\frac{y}{12}$  or  $y + 12$  )



## Final Examinations

- (4) The area of square whose perimeter is 24 cm. equals ..... cm<sup>2</sup>  
(24 or 36 or 16 or 20)
- (5) 0.15 .....  $\mathbb{N}$  (  $\in$  or  $\notin$  or  $\subset$  or  $\not\subset$  )
- (6) If  $x + 1 = 3$ , then  $2x =$  ..... (2 or 3 or 4 or 8)
- (7) 1, 4, 9, 16, ..... (in the same pattern)  
(32 or 24 or 27 or 25)
- (8) If the sum of two numbers A and B is 35, then  $B =$  .....  
(  $A - 35$  or  $35A$  or  $35 - A$  or  $A + 35$  )
- (9) If  $y = 5x + 9$ , then the constant is ..... (5 or 6 or 9 or 8)
- (10) The shaded triangle is the image of the other triangle by a .....  
( reflection or rotation or translation )
- (11) The multiplicative neutral element in  $\mathbb{N} \times$  the additive neutral element in  $\mathbb{N} =$  ..... (0 or 1 or 2 or 3)
- (12) If the base length of a triangle is 8 cm. and its height is 5 cm.  
, then its surface area = ..... cm<sup>2</sup>. (30 or 13 or 40 or 20)
- (13) The area of a rhombus whose diagonals 10 cm. and 20 cm.  
is ..... cm<sup>2</sup>. (200 or 30 or 100 or 400)
- (14) If  $x(75 + 10) = 9 \times 85$ , then  $x =$  ..... (5 or 85 or 9 or 8)

## 2 Complete each of the following :

- (15)  $\frac{\text{The circumference of the circle}}{\text{The length of the diameter}} =$  .....
- (16) The natural number between  $\frac{9}{3}$  and  $\frac{15}{3}$  is .....
- (17) The set of even numbers (E)  $\cup$  the set of odd numbers (O) = .....
- (18) The length of the diagonal of a square with area 72 cm<sup>2</sup> = ..... cm.
- (19)  $53 \times 164 + 47 \times$  ..... =  $164 \times 100$
- (20) The perimeter of equilateral triangle whose side length is  $x$  cm.  
= ..... cm.



**3 Answer the following :**

(21) In the opposite figure , complete :

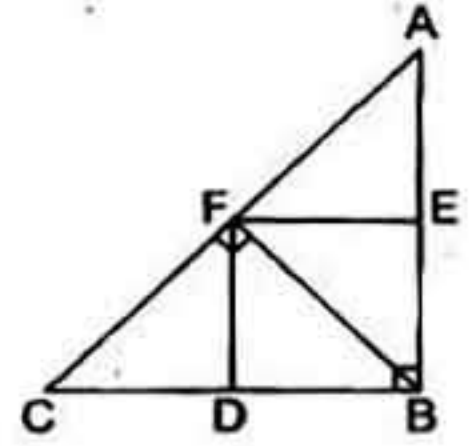
[a]  $\Delta AEF$  is the image of  $\Delta BEF$  by reflection in .....[b]  $\Delta ABF$  is the image of  $\Delta CBF$  by reflection in .....[c]  $\Delta EBF$  is the image of  $\Delta$  ..... by reflection in  $\overrightarrow{BF}$ (22) If  $x = 2$  ,  $y = 1$  and  $z = 7$  , find the value of :[a]  $z + x - y$ [b]  $\frac{z - y}{x}$ (23) Three times of a natural number  $x$  is 8 more than the multiplicative neutral , express this information in an equation and solve it for  $x$ 

(24) Use the commutative and the associative properties to find the result of :

[a]  $4 \times 175 \times 25$ [b]  $102 + 175 + 98$ 

(25) In the opposite figure :

ABCD is parallelogram in which  $AB = 10$  cm. , $DE = 12$  cm. and  $DF = 8$  cm. Find :

[a] The area of the parallelogram ABCD

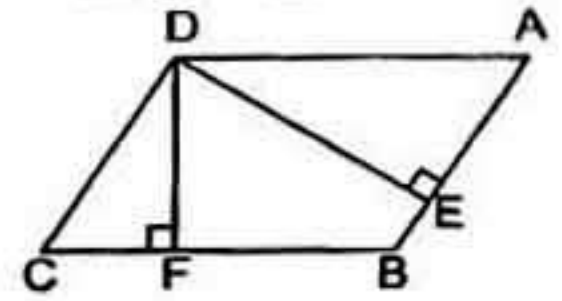
[b] The length of  $\overline{BC}$ (26) Use the distribution property in  $\mathbb{N}$  to find :  $215 \times 101$



## Final Examinations

- (27) Calculate the perimeter of the opposite figure where  $AB = 14$  cm. ( $\pi = \frac{22}{7}$ )

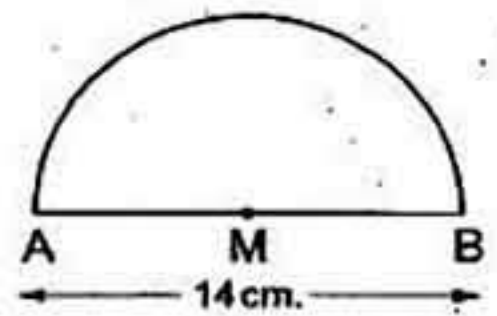

- (28) If  $X = \{x : x \in \mathbb{N}, 1 \leq x < 5\}$ ,  $Y = \{4, 5, 6\}$   
Find : [a]  $X \cap Y$  [b]  $X \cup Y$  [c]  $X - Y$

- (29) Solve the equation :  $x + 3 = 12$  where  $x \in \mathbb{N}$

- (30) Represent the following data by a frequency polygon :

Sets	4 -	6 -	8 -	10 -	Total
Frequency	4	6	5	10	25

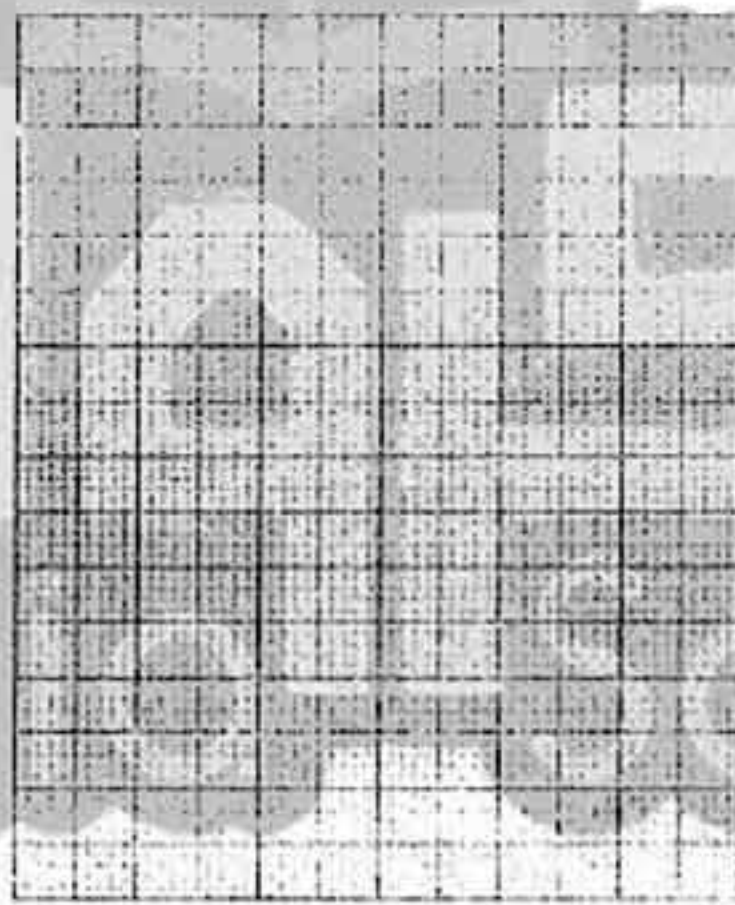

Model

8

Answer the following questions :

- 1 Choose the correct answer :

- (1) The area of the largest rectangle whose perimeter is 24 cm. = .....  $\text{cm}^2$  ( 15 or 36 or 72 or 144 )
- (2) If  $y \div 10 = 50$ , then  $y =$  ..... ( 50 or 100 or 5 or 500 )
- (3) The square whose diagonal length = 8 cm. , its area = .....  $\text{cm}^2$  ( 64 or 32 or 16 or 8 )



- (4)  $\frac{9-5}{3-3} = \dots\dots\dots$  (zero or 3 or 4 or meaningless)
- (5) If  $X = \{x : x \in \mathbb{N}, x \leq 2\}$ , then  $X = \dots\dots\dots$   
( $\{0, 1\}$  or  $\{1\}$  or  $\{0, 1, 2\}$  or  $\emptyset$ )
- (6) If  $y = 3x + 5$ , then the constant is  $\dots\dots\dots$  ( $y$  or  $x$  or 3 or 5)
- (7) If the side lengths of a triangle are equal in length, then the triangle is  $\dots\dots\dots$  triangle. (scalene or isosceles or equilateral)
- (8) Subtract 4 from the number  $a$  the symbolic expression is  $\dots\dots\dots$   
( $2a - 4$  or  $a + 4$  or  $a - 4$  or  $2a + 4$ )
- (9) If  $x + 7 = 9$ ,  $x \in \mathbb{N}$ , then  $x = \dots\dots\dots$  (16 or 2 or 11 or 13)
- (10) If the ordered pair  $(5, 2) = (5, y)$ , then  $y = \dots\dots\dots$   
(2 or 3 or 4 or 5)
- (11) If  $A(2, 3)$ ,  $B(2, 7)$ , then the midpoint of  $\overline{AB}$  is  $\dots\dots\dots$   
( $(10, 4)$  or  $(2, 5)$  or  $(2, 10)$  or  $(0, 9)$ )
- (12) A circumference of a circle is 22 cm., then its diameter length =  $\dots\dots\dots$  cm. (Where  $\pi = \frac{22}{7}$ ) (3.5 or 7 or 8 or 11)
- (13)  $(5 - 9) \dots\dots\dots \mathbb{N}$  ( $\in$  or  $\notin$  or  $\subset$  or  $\not\subset$ )
- (14) The shown transformation is called  $\dots\dots\dots$  b/d  
(reflection or rotation or translation)

### 2 Complete each of the following :

- (15) A triangle whose area =  $120 \text{ cm}^2$ , and its height = 10 cm., then its base length =  $\dots\dots\dots$  cm.
- (16) The multiplicative neutral element in  $\mathbb{N}$  is  $\dots\dots\dots$
- (17)  $47 \times (36 + 64) = 47 \times \dots\dots\dots = \dots\dots\dots$
- (18) If  $5 + 0 = 0 + 5 = 5$ , then it is called  $\dots\dots\dots$  property.
- (19) The set of even numbers – the set of odd numbers =  $\dots\dots\dots$
- (20) The number of axes of symmetry of the rhombus is  $\dots\dots\dots$

### 3 Answer the following :

(21) Which is greater in area ?

A parallelogram of base 10 cm. and corresponding height 6 cm. or a rhombus of diagonals lengths 12 cm. and 16 cm.

$\dots\dots\dots$



## Final Examinations

(22) Solve the following equation :  $5x - 7 = 33$  ,  $x \in \mathbb{N}$

(23) The length of the diameter of the wheel of a bicycle is 56 cm. Calculate the covered distance if the wheel turns one turn and what is the number of turns to cover distance of 352 metres ?

(Where  $\pi = \frac{22}{7}$ )

(24) In the opposite figure :

ABCD is a rectangle of area  $828 \text{ cm}^2$

$E \in \overline{BC}$  ,  $AD = 23 \text{ cm}$ . and  $BE = 35 \text{ cm}$ .

Find the area of  $\triangle DCE$

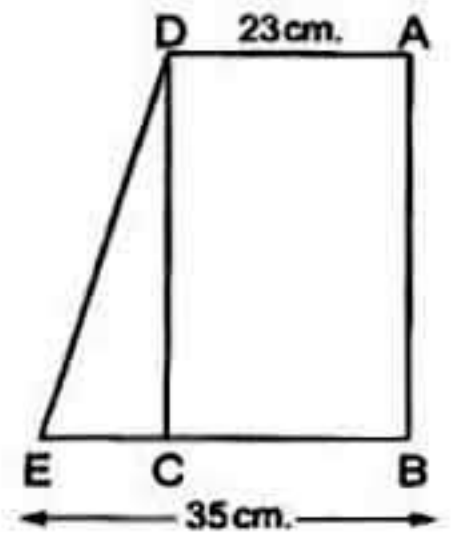

(25) An employee spends his salary as follows :

$\frac{1}{8}$  of it to clothes ,  $\frac{1}{2}$  of it to food

,  $\frac{1}{4}$  of it to medicine and  $\frac{1}{8}$  of it to renting.

If his salary was L.E. 1 600

, then find the spending of food.



(26) In the cartesian coordinates plane , from the following figure :

[a] Complete :

A (..... , .....), B (..... , ..... ) and C (..... , .....)

[b] If L is the axis of reflection of the  $\triangle ABC$  , draw  $\triangle A'B'C'$  the image of  $\triangle ABC$  by reflection in the straight line L

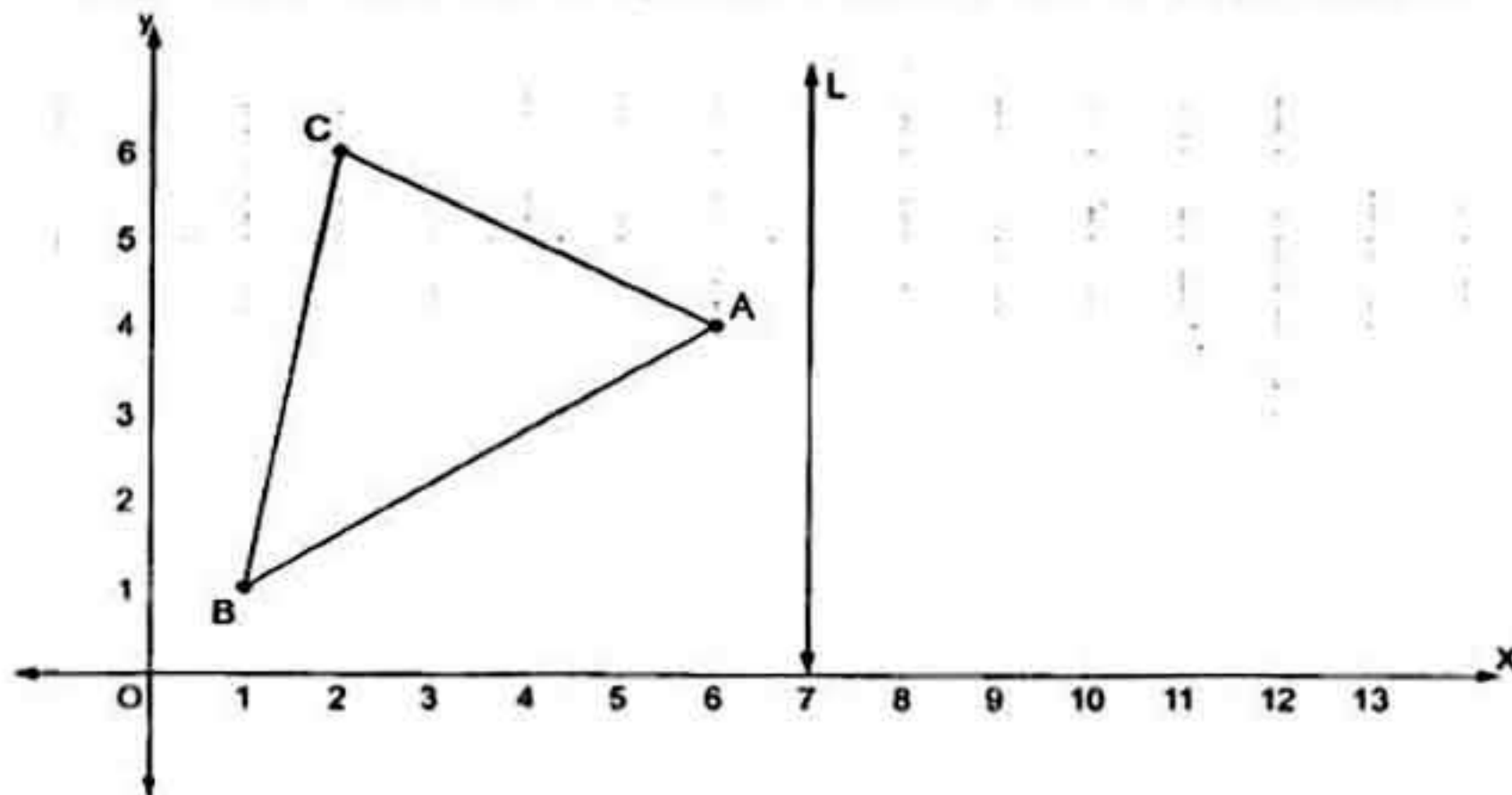



(27) Using the properties of commutation , distribution and association in  $\mathbb{N}$  , find the value of each of the following :

[a]  $137 \times 36 - 37 \times 36$

[b]  $28 + 59 + 72 + 41$

[c]  $8 \times 81 \times 125$

(28) Find the perimeter of the opposite figure :

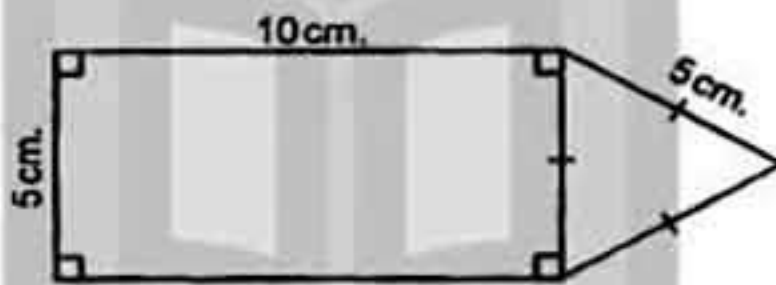

(29) Use the distribution property to find the value of :  $519 \times 99$

(30) The following table shows the marks of 40 pupils in English exam :

Sets	10 –	20 –	30 –	40 –	Total
Frequency	6	k	14	12	40

[a] Find the value of k

[b] Represent these data by the frequency polygon.

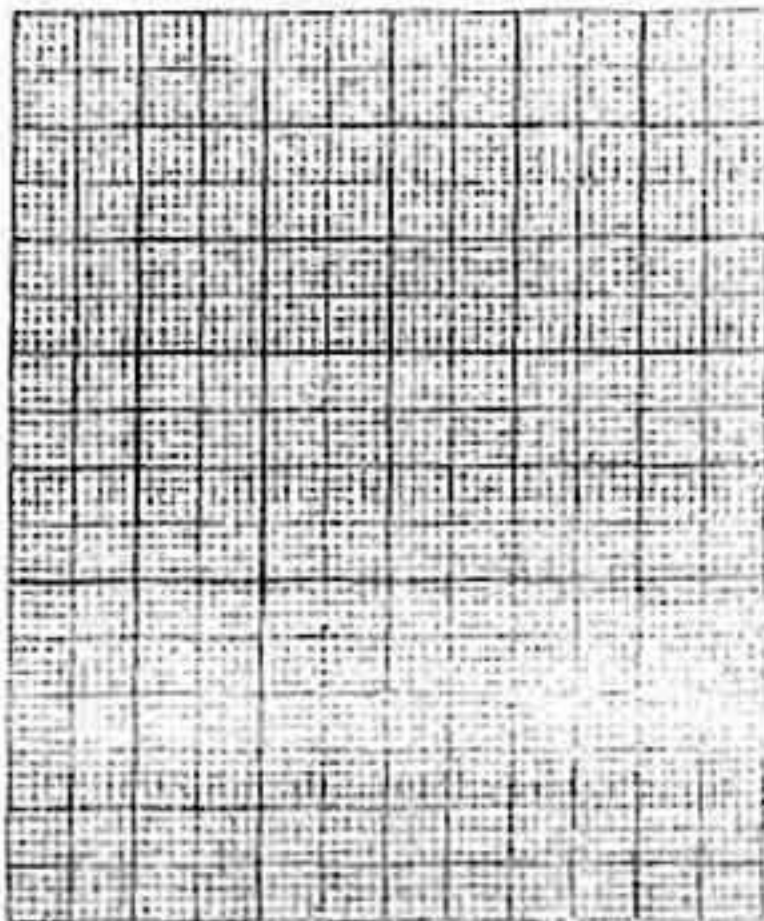



Answer the following questions :

**1 Choose the correct answer :**

(1) If we multiply the number  $x$  by 7 , then we subtract from the result 4 , we shall get .....

(  $7x - 4$  or  $4x + 7$  or  $7x - 3$  or  $3 - 7x$  )

(2) There are ..... axes of symmetry of an equilateral triangle.

( 0 or 1 or 2 or 3 )

(3) Area of the opposite triangle is .....  $\text{cm}^2$

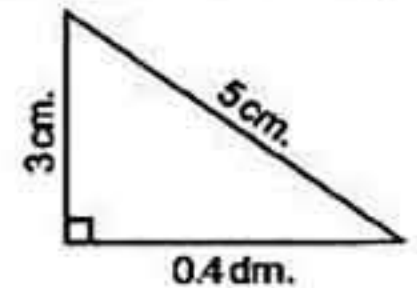

( 12 or 24 or 43 or 6 )

(4) If  $x$  is an odd number , then  $x + 2$  is .....

( even or odd or prime or otherwise )

(5)  $\{5, 6, 7\}$  .....  $\mathbb{N}$  (  $\in$  or  $\notin$  or  $\subset$  or  $\not\subset$  )

(6) If  $3x = 15$  ,  $x \in \mathbb{N}$  , then  $x - 1 =$  ..... ( 5 or 4 or 3 or 2 )

(7) The area of square whose diagonal length is 8 cm. is .....  $\text{cm}^2$

( 10 or 16 or 32 or 64 )

(8) If  $X = \{x : x \in \mathbb{N}, 5 \leq x < 7\}$  , then  $X =$  .....

(  $\{5\}$  or  $\{6\}$  or  $\{5, 6\}$  or  $\{5, 6, 7\}$  )

(9) If the sum of two numbers  $x$  and  $y$  is 20 , then  $y =$  .....

(  $x - 20$  or  $20 - x$  or  $x + 20$  or  $\frac{x}{20}$  )

(10) If the longest chord in a circle is 7 cm. , then the circumference of the circle is ..... cm. (where  $\pi = \frac{22}{7}$ )

( 3.7 or 7 or 22 or 44 )

(11) A parallelogram in which the lengths of two adjacent sides are 5 cm. and 7 cm. , then length of the smaller height = 4 cm. , then its

area = .....  $\text{cm}^2$  ( 20 or 10 or 28 or 14 )

(12) If A (3 , 1) , B (3 , 9) , then the midpoint of  $\overline{AB}$  is .....

( (6 , 10) or (3 , 10) or (3 , 5) or (0 , 10) )



- (13) The perimeter of the equilateral triangle whose side length  $L$  cm. is ..... cm. ( $L + 3$  or  $\frac{1}{3}L$  or  $L - 3$  or  $3L$ )
- (14) The set of odd numbers ..... the set of natural numbers. ( $\in$  or  $\notin$  or  $\subset$  or  $\not\subset$ )

**2 Complete each of the following :**

- (15) If  $A \times 60 + A \times 4 = 3 \times 64$ , then  $A = \dots\dots\dots$
- (16) 2, 7, 12, 17, ..... , ..... (in the same pattern)
- (17) The additive neutral element in  $\mathbb{N}$  is .....
- (18) The perimeter of square whose side length is 10 cm. = ..... cm.
- (19) Area of the triangle =  $\frac{1}{2}$  the length of its base  $\times$  .....
- (20) For any natural numbers  $x$ ,  $y$  and  $z$  where  $(x \times y) \times z = x \times (y \times z)$  is called ..... property.

**3 Answer the following :**

- (21) In a 2-dimensional coordinate plane : Draw the triangle ABC where  $A(2, 1)$ ,  $B(5, 1)$  and  $C(5, 5)$ , then draw the image of the triangle ABC by reflection across  $\overleftrightarrow{BC}$

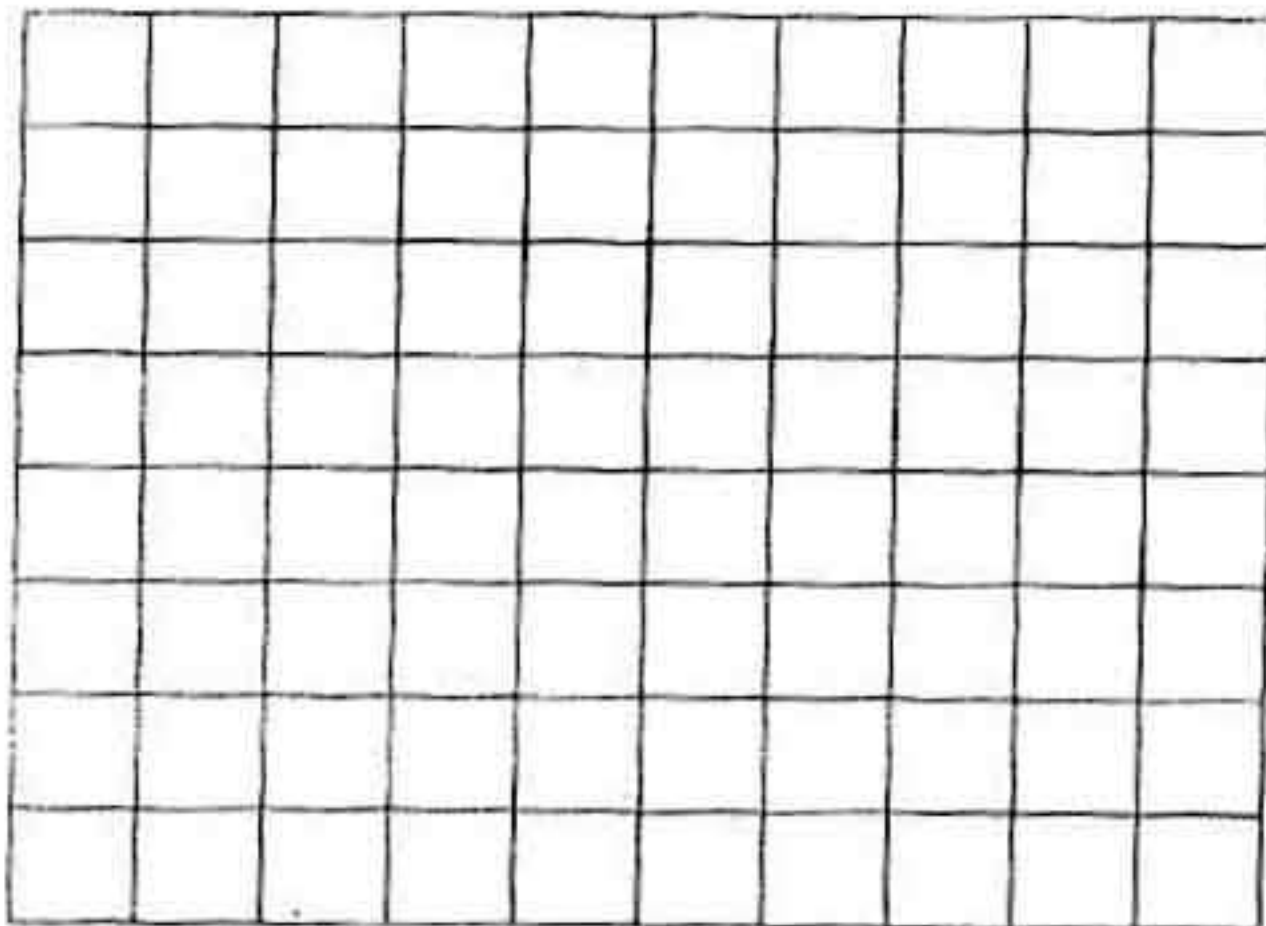



## Final Examinations

(22) Five even natural numbers , the greatest number is  $x + 13$  , write down these numbers.

.....

(23) The area of a rectangle equals the area of a square whose diagonal length is 12 cm. , find the perimeter of the rectangle if its width equals 8 cm.

.....

(24) Solve each of the following equations in  $\mathbb{N}$  :

[a]  $\frac{1}{6}x - 3 = 2$

[b]  $3x + 7 = 19$

.....

.....

(25) Find the area of rhombus whose diagonals lengths 20 cm. and 10 cm.

.....

(26) Calculate using commutative , associative and distributive properties :

[a]  $642 + 171 + 358 + 29$

[b]  $25 \times 304$

.....

.....

(27) If the number  $x$  exceeds twice the number  $y$  by 7 , write down the mathematical relation which relates  $x$  by  $y$

.....

(28) In the opposite figure , there is a window which has the form of square whose side length is 70 cm. and above it there is a semicircle. Calculate the perimeter of the window. (where  $\pi = \frac{22}{7}$ )

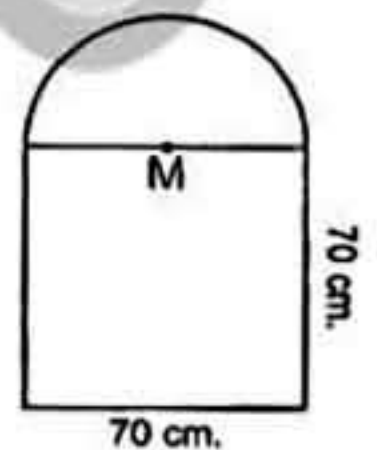

(29) Use distributive property to find the result of :  $18 \times 99$

.....

(30) The following table shows the marks of 40 pupils in an exam :

Sets	10 -	20 -	30 -	40 -	50 -	Total
Frequency	5	7	12	A	7	40



[a] Find the value of A

[b] Draw the histogram and the frequency polygon which represent these data.

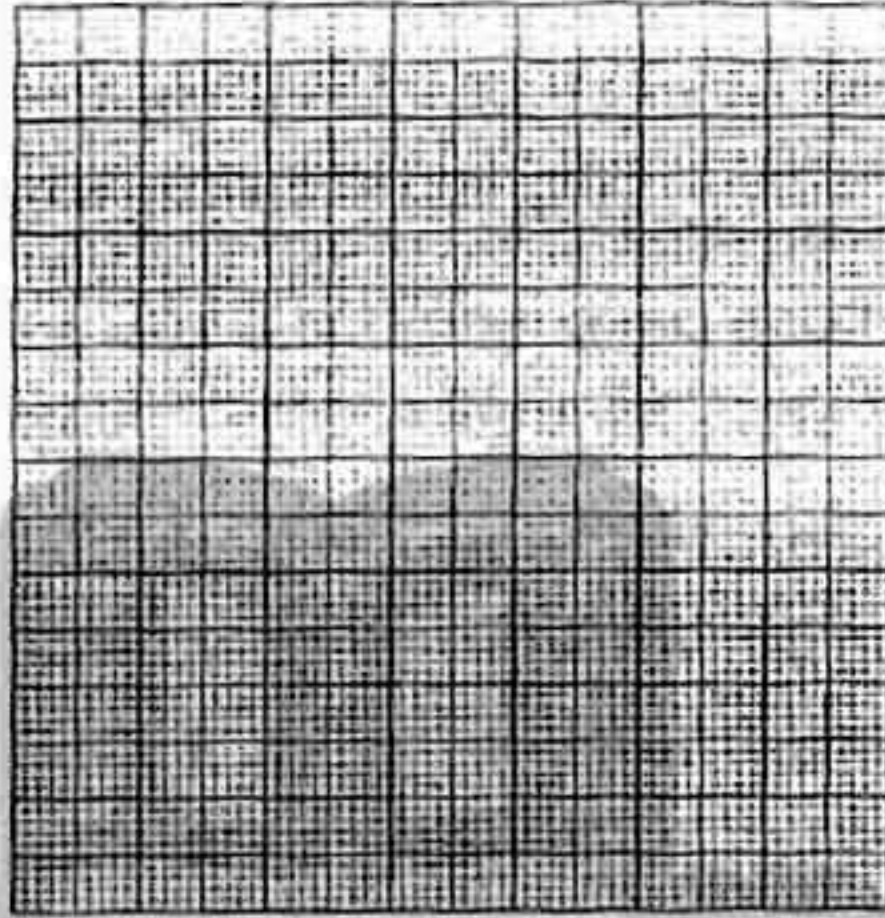

Model

10

Answer the following questions :

1 Choose the correct answer :

- (1) The diameter length of the circle whose circumference is 88 cm. equals ..... cm. (28 or 14 or 21 or 7)
- (2) If  $x + 8 = 15$ ,  $x \in \mathbb{N}$ , then  $x =$  ..... (3 or 7 or 6 or 5)
- (3) Add 5 to double number a is written as ..... (5a + 2 or 5 + a or 2a + 5 or 2a - 5)
- (4) The area of the rhombus whose side length is 8 cm. and its height is 4 cm. equals ..... cm<sup>2</sup> (12 or 16 or 32 or 64)
- (5)  $75 \times 99 = 75 \times (100 - \dots)$  (100 or 75 or 1 or 0)
- (6) The smallest natural number is ..... ( $\frac{1}{7}$  or 0 or 1 or  $\frac{1}{2}$ )
- (7) The opposite geometric transformation is .....  (reflection or rotation or translation)
- (8) The square has ..... lines of symmetry. (1 or 2 or 4 or infinite)



## Final Examinations

(9) If  $7y = 84$ , then  $\frac{1}{2}y = \dots\dots\dots$  (6 or 12 or 21 or 42)

(10) If  $\mathbb{N}$  is the set of natural numbers,  $a \in \mathbb{N}$ ,  $b \in \mathbb{N}$ ,  
then  $a + b \dots\dots\dots \mathbb{N}$  ( $\in$  or  $\notin$  or  $\subset$  or  $\not\subset$ )

(11) The ordered pair  $(2, 7) = (x, 7)$ , then  $x = \dots\dots\dots$   
(5 or 4 or 7 or 2)

(12) The triangle whose base length is 5 cm. and the corresponding  
height of it is 8 cm., its area =  $\dots\dots\dots$  cm<sup>2</sup>  
(13 or 20 or 26 or 40)

(13) If the difference between two numbers  $a$  and  $b$  is 35,  $a$  is the  
greater number, then  $b = \dots\dots\dots$   
( $35 - a$  or  $35 + a$  or  $a - 35$  or  $\frac{a}{35}$ )

(14) If  $X = \{x : x \in \mathbb{N}, 2 \leq x \leq 3\}$ , then  $X = \dots\dots\dots$   
( $\{2, 3\}$  or  $\{2\}$  or  $\{3\}$  or  $\emptyset$ )

**2** Complete each of the following :

(15) The square whose perimeter is 36 cm., then its area =  $\dots\dots\dots$  cm<sup>2</sup>

(16) The next number in the pattern : 1, 4, 7, 10 ;  $\dots\dots\dots$

(17)  $425 + 575 = 575 + \dots\dots\dots$  ( $\dots\dots\dots$  property)

(18) On the coordinate plane :  $M(5, 1)$ ,  $N(5, 6)$ , then  
 $MN = \dots\dots\dots$  length units.

(19) If  $x$  is an even number, then  $(x - 1)$  is an  $\dots\dots\dots$  number.

(20) If  $87 \times 15 = 87 \times x + 87 \times 10$ , then  $x = \dots\dots\dots$

**3** Answer the following :

(21) Use the properties of the operations to find :

[a]  $872 + 199 + 128 + 801$

[b]  $56 \times 1\,001$



(22) If the age of a man now is  $x$  years , find :

[a] The age of the man after 5 years .....

[b] The age of the man since 7 years .....

(23) Find the area of the shaded part  
where the outer shape is a rectangle  
and the inner shape is a square.

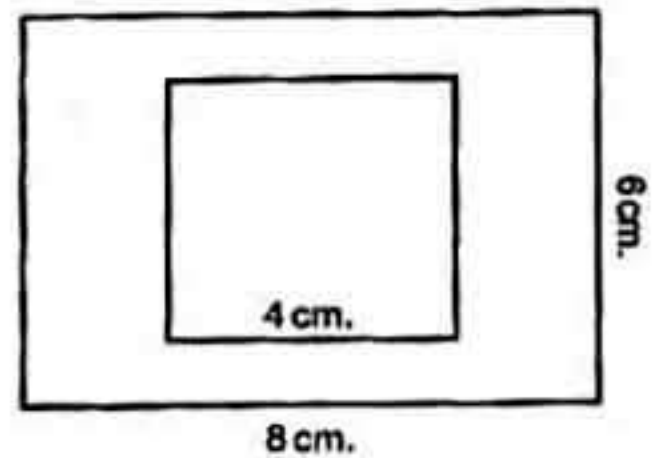

(24) Solve the equations :

[a]  $2x - 3 = 11$  ,  $x \in \mathbb{N}$

[b]  $\frac{1}{2}x + 8 = 10$  ,  $x \in \mathbb{N}$

(25) In a coordinate plane , locate the points A (5 , 0) , B (9 , 0)  
, C (9 , 4) and D (5 , 4) , name the shape ABCD , then draw the  
image of ABCD by reflection across  $\overline{AD}$

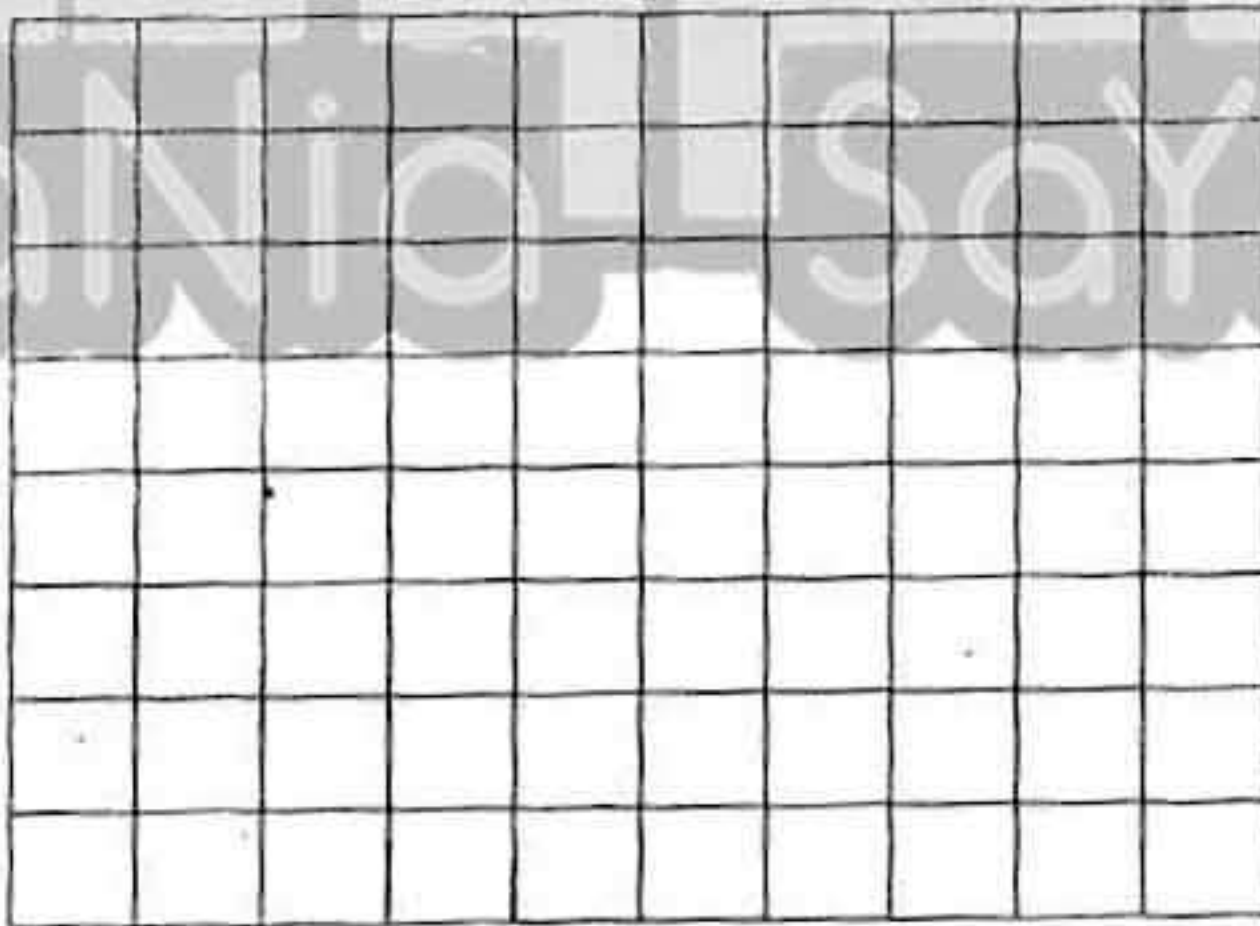

(26) By using the properties of multiplication find the value of :

[a]  $4 \times 31 \times 25$

[b]  $5 \times 99$



## Final Examinations

(27) If the height of a parallelogram is 8 cm. and the length of corresponding base is 10 cm. , calculate the area of the parallelogram.

.....

(28) If  $a = 5$  ,  $b = 2$  and  $c = 3$  , find the value of :

[a]  $a + c - b$

[b]  $\frac{a-c}{b}$

.....

.....

(29) Find the eighth term in the sequence : 1 , 3 , 6 , 10 , .....

.....

(30) The following table shows the marks of 50 pupils in exam of Arabic in one month :

Sets	10 -	20 -	30 -	40 -	Total
Frequency	10	12	18	10	50

Draw a histogram which represents these data.

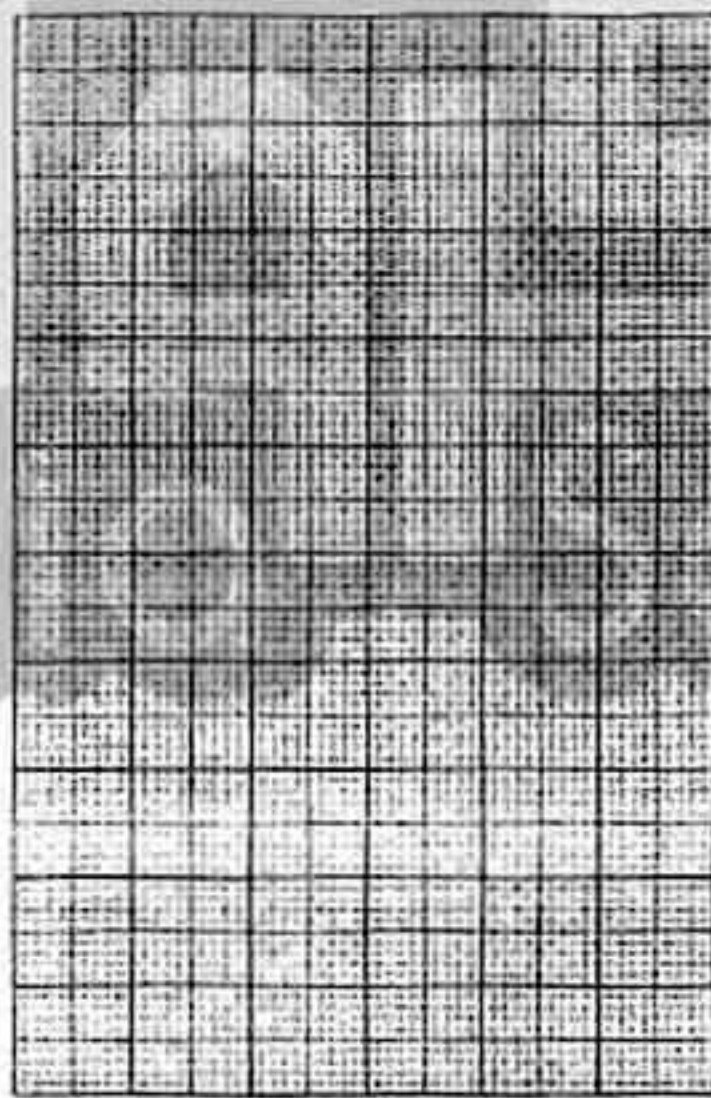

Model

11

Answer the following questions :

1 Choose the correct answer :

( 1 ) 5 is subtracted from twice the number  $x = \dots\dots\dots$

(  $5 - x$  or  $2x - 5$  or  $5x + 2$  or  $5 - 2x$  )

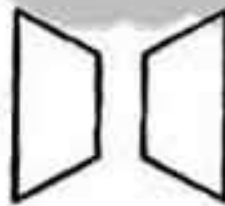

- (2) The diameter length of a circle whose circumference is 88 cm.  
= ..... cm. (28 or 14 or 7 or 21)
- (3) Youssef saved L.E.  $x$  and his father gave him L.E. 15, then he has  
L.E. .... (  $x + 15$  or  $15 - x$  or  $x - 15$  or  $x$  )
- (4) If the area of a square is  $200 \text{ cm}^2$ , then the length of its diagonal is  
..... cm. (16 or 18 or 15 or 20)
- (5) If  $x = 3$ ,  $y = 5$ , then  $4x - 2y =$  ..... (2 or 5 or 14 or 22)
- (6) If  $\mathbb{N}$  is the set of natural numbers,  $a \in \mathbb{N}$ ,  $b \in \mathbb{N}$   
, then  $a \times b$  .....  $\mathbb{N}$  ( $\in$  or  $\notin$  or  $\subset$  or  $\not\subset$ )
- (7)  $\frac{0}{7}$  .....  $\mathbb{N}$  ( $\in$  or  $\notin$  or  $\subset$  or  $\not\subset$ )
- (8) The number of symmetry axes of an equilateral triangle = .....  
(3 or 2 or 1 or 0)
- (9) If  $6 \times 12 = 12 \times x$ , then  $x =$  ..... (4 or 6 or 7 or 8)
- (10) If the side length of a square is  $L$ , then its perimeter = .....  
(  $L + 4$  or  $L - 4$  or  $2L$  or  $4L$  )
- (11)  $\{1, 2, 3\}$  .....  $\mathbb{O}$  ( $\in$  or  $\notin$  or  $\subset$  or  $\not\subset$ )
- (12) If  $3x + 7 = 19$ ,  $x \in \mathbb{N}$ , then  $x =$  ..... (2 or 3 or 4 or 5)
- (13) The area of a triangle whose base length 5 cm. and corresponding  
height 6 cm. is .....  $\text{cm}^2$ . (30 or 15 or 25 or 36)

- (14) The opposite geometric transformation  is .....  
( translation or rotation or reflection )

## 2 Complete each of the following :

- (15)  $\mathbb{N} - \{0\} =$  .....
- (16) The radius length of the circle =  $\frac{\text{.....}}{2\pi}$
- (17)  $32 + (59 + \text{.....}) = (32 + 68) + \text{.....}$
- (18) A rhombus its area is  $50 \text{ cm}^2$  and the length of one of its diagonals  
25 cm. , then the length of the other diagonal = ..... cm.



## Final Examinations

(19) If  $b = 3$  , then  $2b - 5 = \dots\dots\dots$

(20) If  $654 = (x \times 100) + 54$  , then  $x = \dots\dots\dots$

**3 Answer the following :**

- (21) Draw the image  
of  $\triangle ABC$  by reflection  
in the straight line L

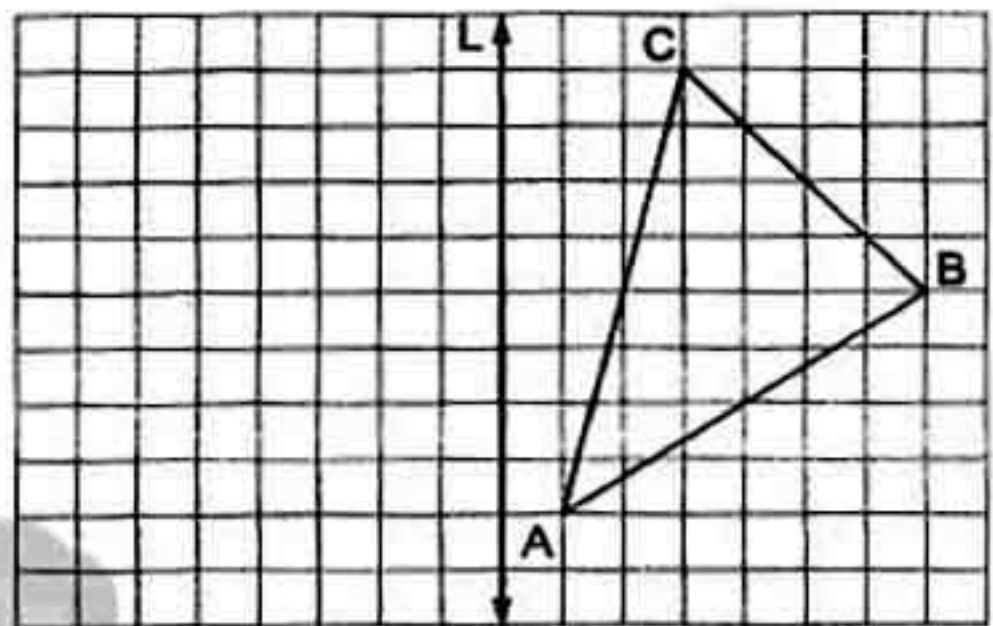

- (22) If the number  $x$  exceeds twice the number  $y$  by 9 , write the  
mathematical relation between  $x$  and  $y$
- .....

- (23) A parallelogram of area  $36 \text{ cm}^2$  and the length of its base is 4 cm.  
Find the corresponding height of its base.
- .....

- (24) Solve the equations in  $\mathbb{N}$  :

[a]  $x - 3 = 21$

[c]  $3y = 27$

- (25) On a coordinate plane, draw the figure ABCD where A (1 , 1) , B (4 , 1)  
, C (4 , 3) , D (1 , 3) , then complete :

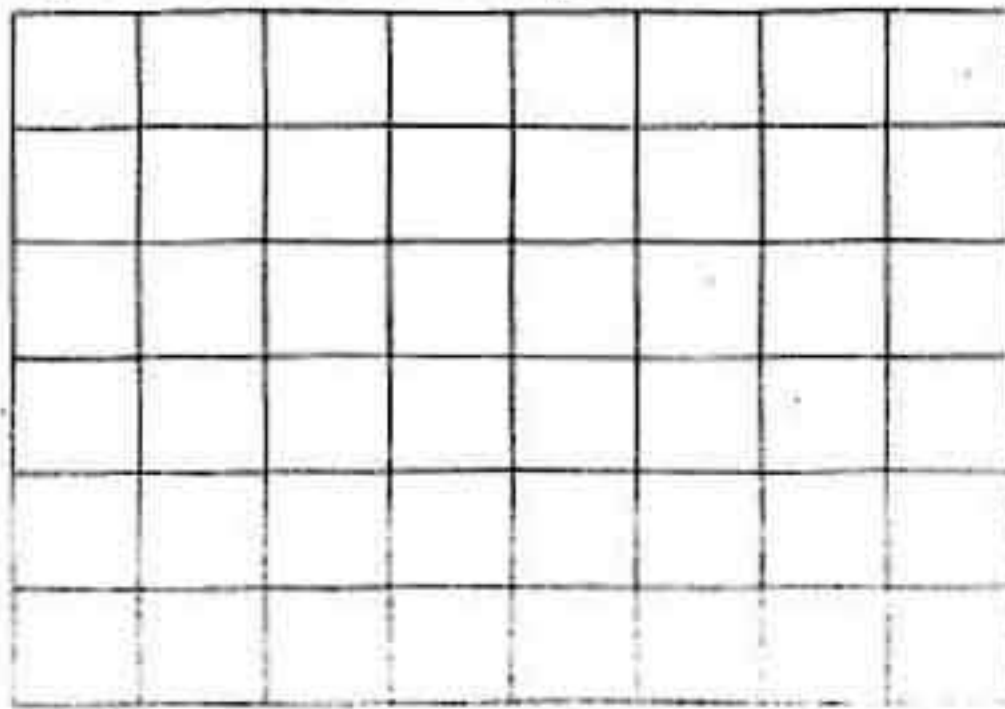

[a] The length of  $\overline{AB} = \dots\dots\dots$  units.

[b] The name of the figure ABCD is .....







Answer the following questions :

1 Choose the correct answer :

(1) The diameter of circle = ..... ( r or 2r or 3r or 4r )

(2) If  $x + 8 = 18$  , then  $x - 1 =$  ..... ( 11 or 10 or 9 or 8 )

(3) If the diagonals lengths of a rhombus are 10 cm. and 12 cm. , then its area = .....  $\text{cm}^2$  ( 120 or 60 or 24 or 32 )

(4)  $\{3, \frac{15}{4}\}$  .....  $\mathbb{N}$  (  $\in$  or  $\notin$  or  $\subset$  or  $\not\subset$  )

(5) If we subtract 5 from a , we get ..... ( 5a or 5-a or a-5 or a+5 )

(6) If A (2 , 4) , B (2 , 6) , then the midpoint of  $\overline{AB}$  is ..... ( (10 , 4) or (2 , 5) or (2 , 10) or (0 , 9) )

(7) The square has ..... axes of symmetry. ( 0 or 2 or 3 or 4 )

(8) The area of a triangle whose base length 5 cm. and the corresponding height 6 cm. is .....  $\text{cm}^2$  ( 3 or 11 or 15 or 60 )

(9) If the sum of two numbers x and y is 25, then  $y =$  ..... (  $x - 25$  or  $25 - x$  or  $x + 25$  or  $\frac{x}{25}$  )

(10) If O is the set of odd numbers, then  $O$  .....  $\mathbb{N}$  (  $\in$  or  $\notin$  or  $\subset$  or  $\not\subset$  )

(11) A square whose diagonal length is 12 cm. , its area = .....  $\text{cm}^2$  ( 144 or 84 or 72 or 60 )

(12) The geometric transformation  is ..... ( translation or rotation or reflection )

(13) If the circumference of a circle is 314 cm. , then its radius length = ..... cm. where  $\pi = 3.14$  ( 100 or 75 or 50 or 25 )

(14) If  $7 \times 95 = x \times (75 + 20)$  , then  $x =$  ..... ( 5 or 95 or 7 or 9 )



**2 Complete each of the following :**(15) If the age of a man now is  $x$  years, then his age after 5 years = .....(16) If the long base of parallelogram is 8 cm. , short base 5 cm. and its short height is 4 cm. , then its area = ..... cm<sup>2</sup>

(17) 1 , 2 , 3 , 5 , 8 , ..... , ..... (in the same pattern)

(18) The property used in :  $a \times (b \times c) = (a \times b) \times c$  is .....(19) The additive neutral element in  $\mathbb{N}$  is .....(20) The set  $\{a : a \in \mathbb{N} , a < 4\}$  in the listing method = .....**3 Answer the following :**

(21) Use the commutative and the associative properties to simplify finding the result of :

[a]  $98 + 175 + 102$

[b]  $5 \times 312 \times 20$

(22) In the orthogonal cartesian coordinates , locate the points A (8 , 2) , B (3 , 2) , C (3 , 6) , D (8 , 6) , then complete :

[a] The length of  $\overline{AB}$  = ..... units, the length of  $\overline{BC}$  = ..... units.

[b] The figure ABCD is .....

[c] The perimeter of the figure ABCD = ..... units.

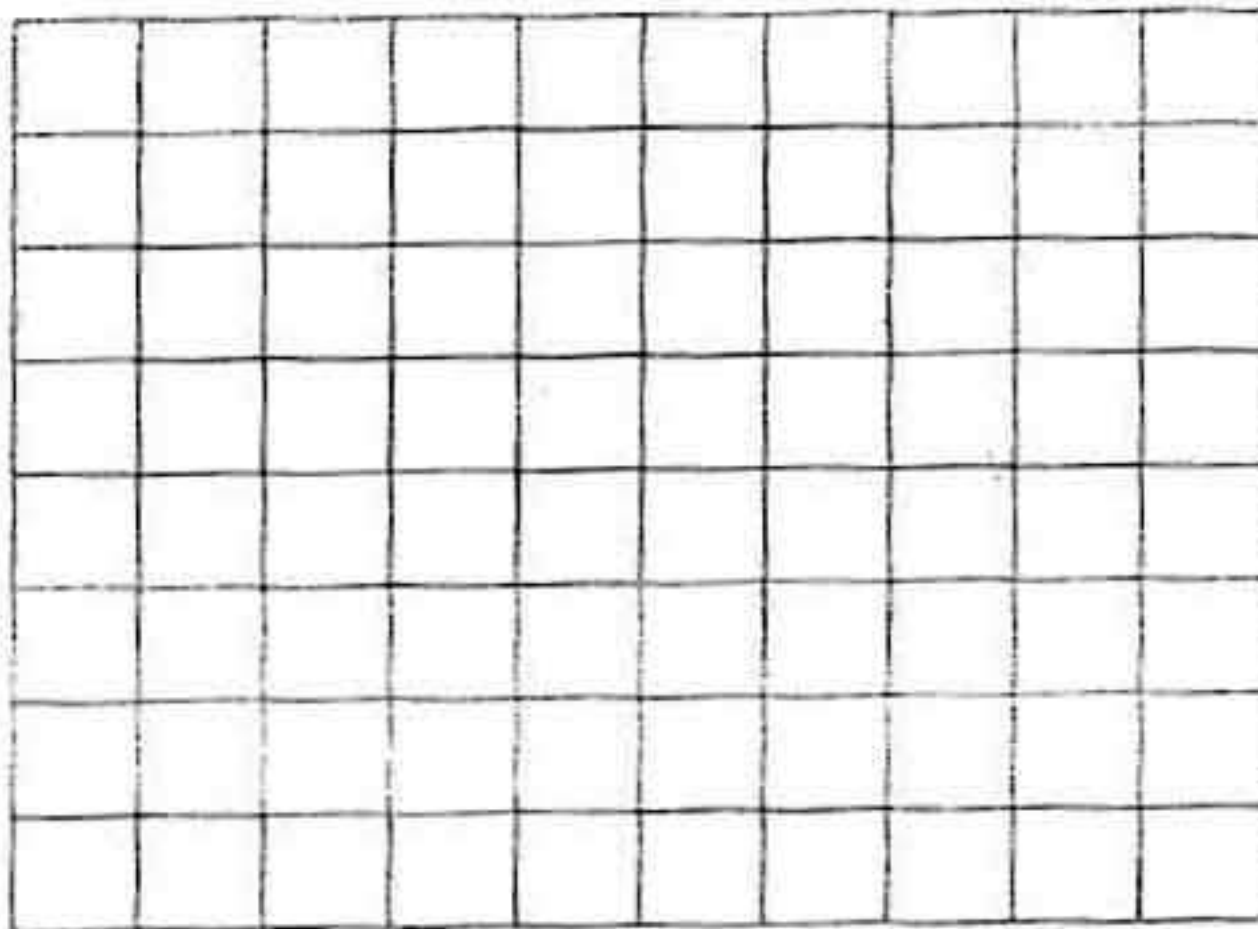



## Final Examinations

(23) Solve in  $\mathbb{N}$  the equations : [a]  $3x + 8 = 29$  [b]  $\frac{1}{3}x + 8 = 10$

(24) In the opposite figure :

ABCD is a square , its perimeter is 60 cm. ,  $E \in \overline{BC}$  and  $BE = 35$  cm.  
Find the area of the figure ABED

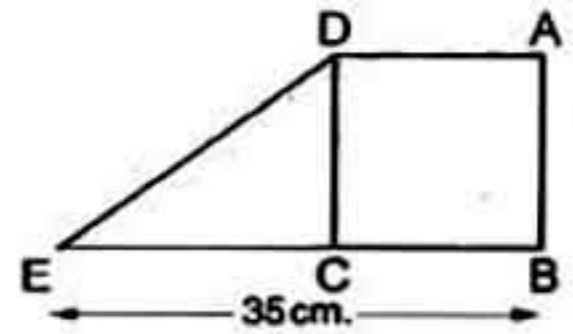

(25) Shady saved 14 pounds , he bought 3 notebooks of  $x$  pounds for each. The remainder with him was 8 pounds , express these situation by an equation.

(26) Use the distribution property in  $\mathbb{N}$  to find :

[a]  $111 \times 98$

[b]  $315 \times 101$

(27) An employes spends his monthly salary as follows : 1000 pounds for food, 500 pounds for clothes, 250 pounds for the rent of the flat and 250 pounds for other spending.

Represent there data on the shown circular sectors.

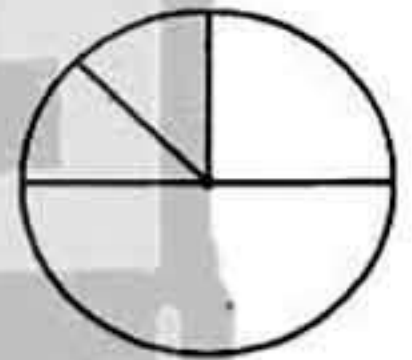

(28) On the coordinate plane, draw  $\Delta ABC$  where  $A(3, 5)$  ,  $B(6, 5)$  ,  $C(3, 2)$  , then draw the image of  $\Delta ABC$  by reflection across  $AC$

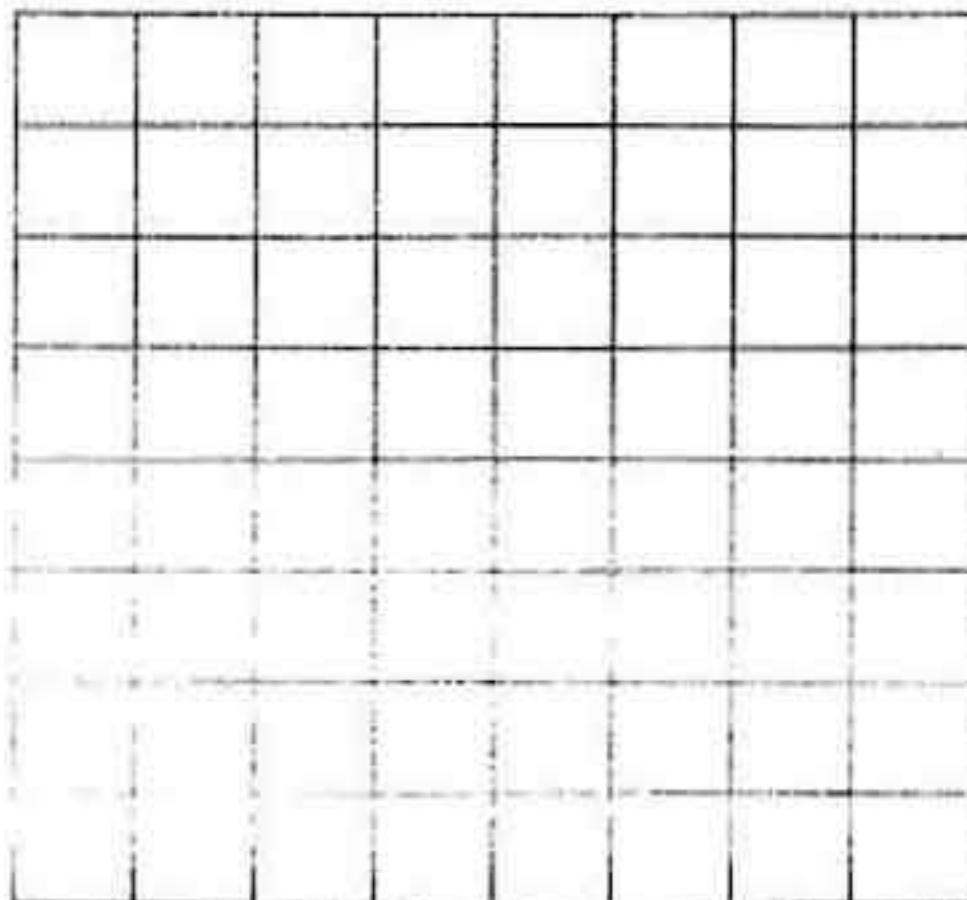



- (29) Calculate the perimeter of the opposite figure where  $\overline{AB}$  is the diameter of the circle and  $AB = 14$  cm. (Consider  $\pi = \frac{22}{7}$ )

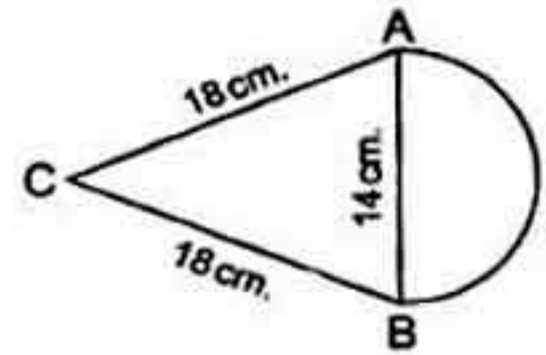

- (30) The following table shows the daily wages of workers in a company :

Sets	20 –	30 –	40 –	50 –	60 –	Total
Frequency	8	10	16	12	4	50

Draw the histogram and frequency polygon which represent these data.

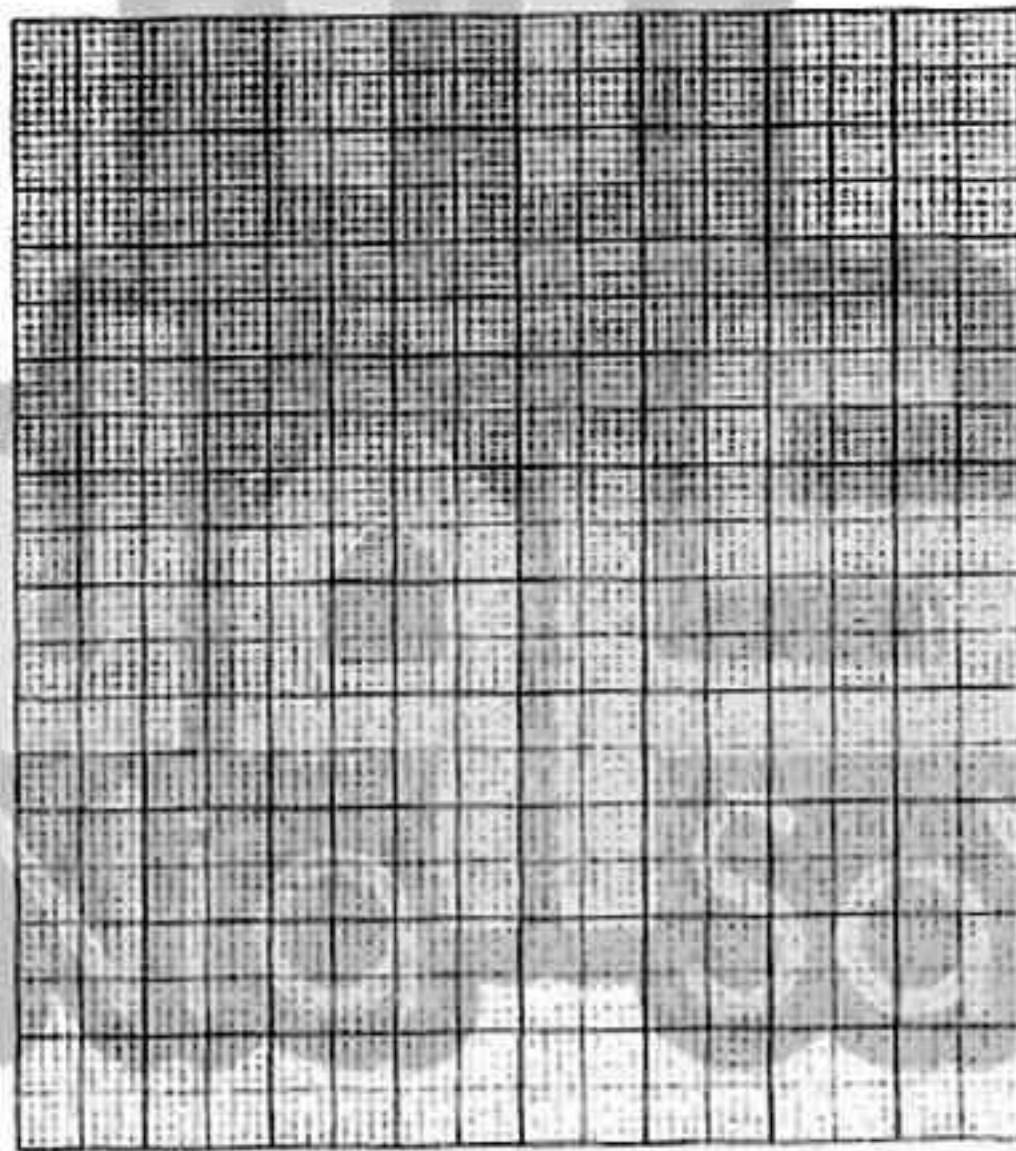

Model 13

Answer the following questions :



تابعنا على صفحتنا على الفيسبوك

[www.facebook.com/ZakroolySite](http://www.facebook.com/ZakroolySite)

- 1 Choose the correct answer :

(1) If the area of a rhombus equals  $24 \text{ cm}^2$  and the length of one of its diagonals is 8 cm. , then the length of the other diagonal = ..... cm.

( 3 or 6 or 8 or 12 )

(2) The next term in the pattern : 5 , 25 , 45 , ..... is .....

( 15 or 35 or 50 or 65 )



## Final Examinations

- (3) The number of axes of symmetry of scalene triangle is .....  
(0 or 1 or 2 or 3)
- (4) The multiplicative identity element in  $\mathbb{N}$  is .....  
(0 or 1 or 2 or 3)
- (5) If  $X = \{x : x \in \mathbb{N}, 0 < x < 1\}$ , then  $X =$  .....  
( $\emptyset$  or  $\{0, 1\}$  or  $\{0\}$  or  $\{1\}$ )
- (6) If  $2a + 7 = 15$ ,  $a \in \mathbb{N}$ , then  $a =$  ..... (22 or 11 or 8 or 4)
- (7) If  $x$  is an odd number, then  $x + 2$  is ..... number.  
(odd or even or prime)
- (8)  $(4 \times \dots) \times 78 = 7800$  (5 or 25 or 50 or 125)
- (9)  $c \dots a$   where  $a, c$  are two natural numbers.  
( $>$  or  $<$  or  $=$  or  $\leq$ )
- (10) Adding 8 to double  $x$ , the symbolic expression is .....  
( $2x + 8$  or  $8 - 2x$  or  $x + 8$  or  $8 + 3x$ )
- (11) The circumference of a circle whose diameter is 14 cm.  
equals ..... cm. ( $\pi = \frac{22}{7}$ ) (100 or 88 or 44 or 22)
- (12) The least prime number  $\times$  any prime number = ..... number.  
(odd or even or prime or otherwise)
- (13) If the ordered pair  $(3, 4) = (3, y)$ , then  $y =$  .....  
(2 or 3 or 4 or 5)
- (14)  $\frac{5}{7} \dots \mathbb{N}$  ( $\in$  or  $\notin$  or  $\subset$  or  $\not\subset$ )

## 2 Complete each of the following :

- (15)  $91 \times (73 + 27) = 91 \times \dots = \dots$
- (16) Area of square =  $\frac{1}{2} \times \dots \times \dots$
- (17) Circumference of the circle  $\div$  diameter length = .....
- (18) The perimeter of an equilateral triangle whose side length is  $L$  cm. = ..... cm.
- (19) The length of the base of the triangle is 8 cm. and its height is 5 cm.  
, then its area = .....  $\text{cm}^2$
- (20) The square whose diagonal length is 8 cm. , its area = .....  $\text{cm}^2$



## 3 Answer the following :

(21) Which is greater in area ? a rhombus in which the lengths of its diagonals are 8 cm. and 6 cm. or the parallelogram in which the length of its base is 10 cm. and the corresponding height is 5 cm. , then calculate the difference between them.

.....

.....

(22) Solve the following equations in  $\mathbb{N}$  :

[a]  $x + 3 = 12$

[b]  $2x - 7 = 5$

(23) On the coordinate plane draw  $\triangle ABC$  where A (2 , 1) , B (5 , 1) , C (5 , 5) , then draw the image of  $\triangle ABC$  by reflection in  $\overline{BC}$

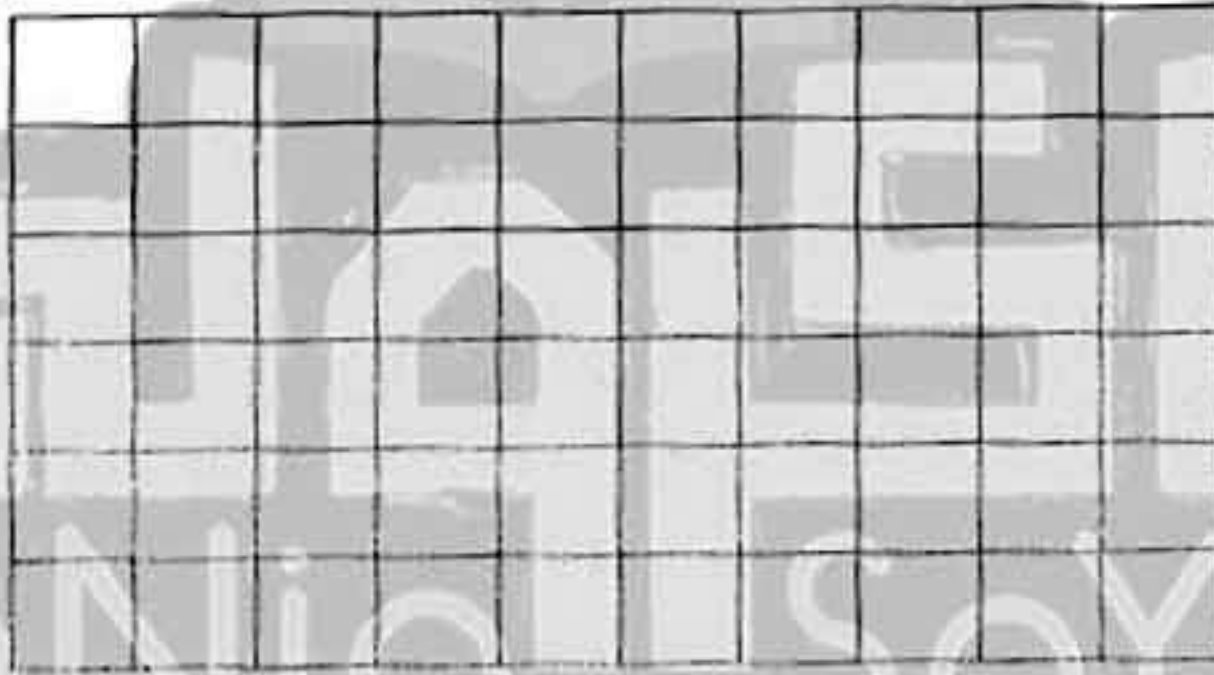

(24) If  $X = \{x : x \in \mathbb{N}, 1 < x \leq 6\}$  ,  $Y = \{5, 6, 7\}$  , find :

[a]  $X \cap Y$

[b]  $X \cup Y$

[c]  $X - Y$

(25) Calculate using commutative , associative and distributive properties :

[a]  $25 \times 304$

[b]  $642 + 171 + 358 + 29$

(26) In the opposite figure :

ABC is a triangle ,  $\overline{CE} \perp \overline{AB}$

, if  $AB = 6$  cm. ,  $BC = 5$  cm. and  $CE = 4$  cm.

Find the area of  $\triangle ABC$

.....

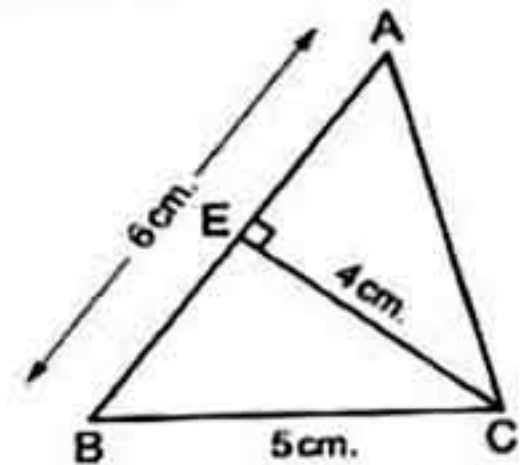



## Final Examinations

(27) If the diameter length of a bicycle's wheel is 66 cm. , what is the covered distance if the wheel turns 1000 rounds ? (Where  $\pi = 3.14$ )

(28) Calculate the perimeter of the following figure (where  $\pi = \frac{22}{7}$ )

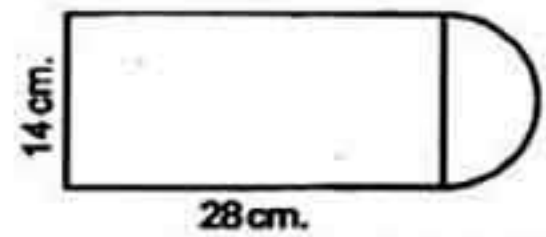

(29) Find the number which if added to 3 , the sum will be 9

(30) The following table shows the frequency distribution of the number of work hours of 50 workers :

Sets	2 -	4 -	6 -	8 -	10 -	Total
Frequency	8	9	15	16	2	50

Graph these data using the frequency polygon :

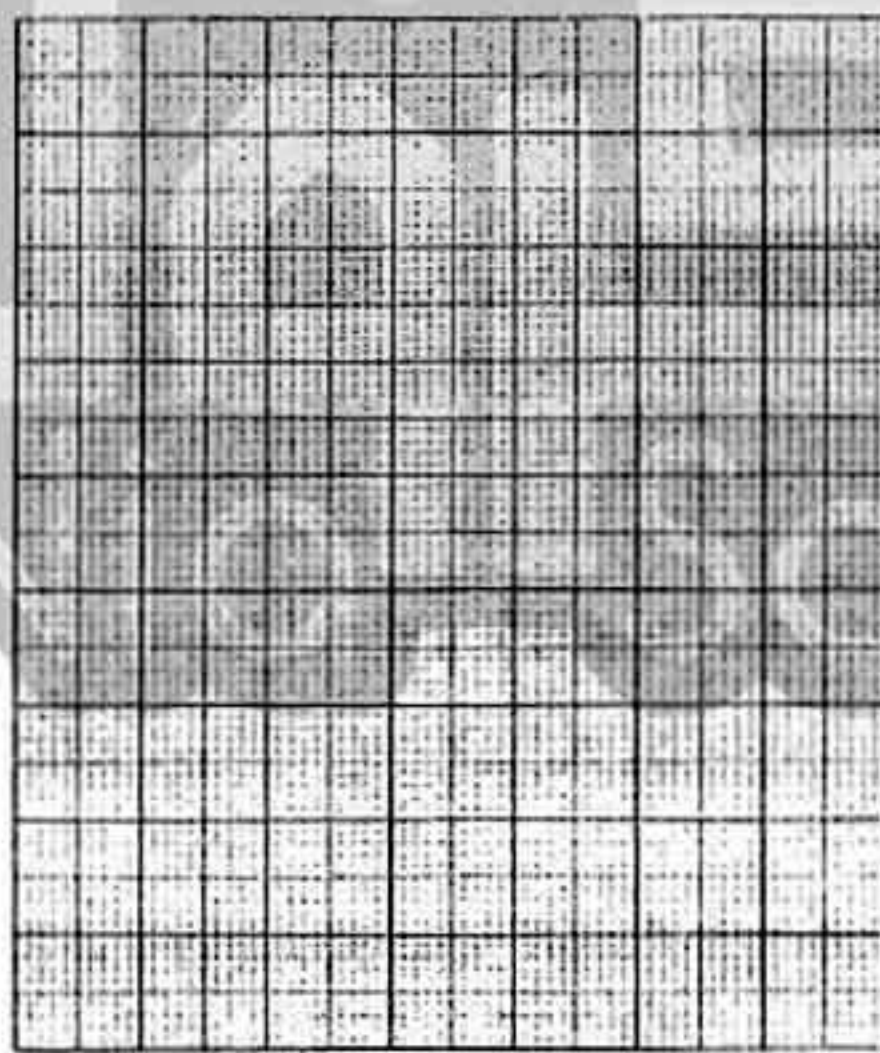

Model

14

Answer the following questions :

1 Choose the correct answer :

( 1 ) The set of even numbers (E)  $\cap$  the set of prime numbers (P) = .....  
( P or {0} or  $\mathbb{N}$  or {2} )



- (2) The difference between two numbers is 5 , the smaller one is  $y$  , then the greater number is .....
- ( 5 y or 5 - y or y - 5 or y + 5 )
- (3) The number of axes of symmetry of the rhombus = .....
- ( 1 or 2 or 3 or 4 )
- (4) If  $y + 5 = 20$  , then  $y =$  .....
- ( 4 or 15 or 25 or 100 )
- (5) If we multiply the number  $a$  by 9 , then we subtract 4 from the result , we get .....
- ( 9 a + 4 or 4 a + 9 or 9 a - 4 or a - 36 )
- (6)  $\{2, \frac{1}{2}\}$  .....  $\mathbb{N}$  (  $\in$  or  $\notin$  or  $\subset$  or  $\not\subset$  )
- (7) The circumference of a circle whose diameter is 21 cm. equals ..... cm. ( $\pi = \frac{22}{7}$ ) ( 22 or 44 or 66 or 88 )
- (8) The shaded triangle is an image of other triangle by ..... 
- ( reflection or translation or rotation )
- (9) A rhombus in which the lengths of its diagonals are 10 cm. and 12 cm. , its area = .....  $\text{cm}^2$  ( 120 or 60 or 24 or 32 )
- (10) The square whose perimeter is 16 cm. , its area = .....  $\text{cm}^2$  ( 4 or 7 or 8 or 16 )
- (11)  $5 \times (2 + 10) =$  ..... ( 50 or 60 or 75 or 100 )
- (12) 1 , 4 , 7 , 10 , ..... (in the same pattern) ( 15 or 20 or 13 or 17 )
- (13) The triangle whose base length is 5 cm. and the corresponding height of it is 8 cm. , its area = .....  $\text{cm}^2$  ( 40 or 26 or 20 or 13 )
- (14) The ordered pair  $(3, 4) = (x, 4)$  , then  $x =$  ..... ( 2 or 3 or 4 or 7 )

## 2 Complete each of the following :

- (15)  $15 \times 5 + 15 \times 7 = 15$  ( ..... + ..... )
- (16) If  $7 + 0 = 0 + 7 = 7$  , then the used property is called .....
- (17) The symmetry axis divides the figure into two ..... halves.
- (18) The multiplicative neutral element in  $\mathbb{N}$  is .....



## Final Examinations

(19) The square whose area is  $18 \text{ cm}^2$ , then its diagonal length is ..... cm.

(20) If  $X = \{x : x \in \mathbb{N}, x < 3\}$ , then  $X = \dots\dots\dots$

**3** Answer the following :

(21) Use the properties to find :

[a]  $73 \times 1001$

[b]  $872 + 199 + 128 + 801$

.....  
 .....

(22) In the coordinate plane draw the triangle ABC where A (2 , 4) , B (4 , 2) , C (4 , 7) , then draw the image of the triangle ABC by reflection across  $\overline{BC}$

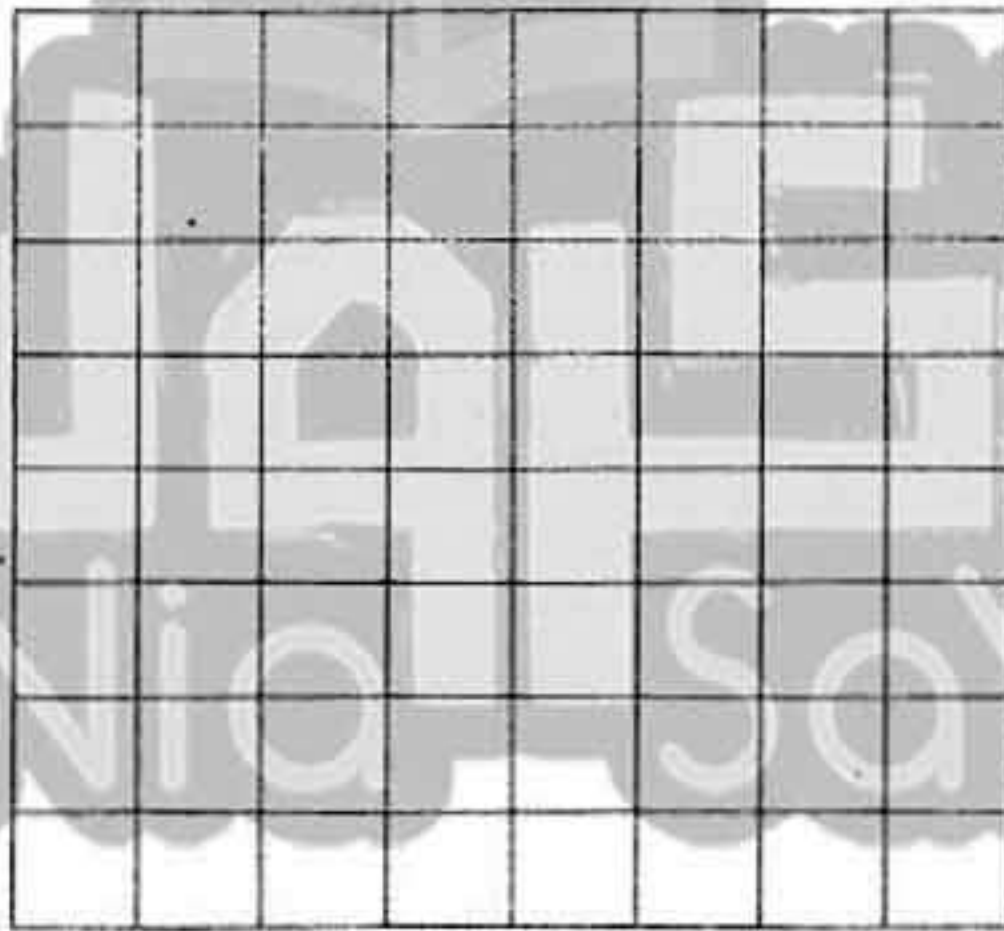

(23) Solve the equations in  $\mathbb{N}$  :

[a]  $2x + 9 = 21$

[b]  $5 - y = 3$

.....  
 .....

(24) Find the area of the opposite parallelogram :

.....

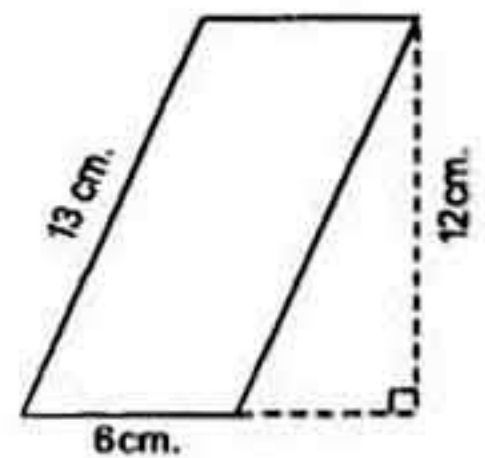



(25) Use the properties of operations in  $\mathbb{N}$  to find :

[a]  $25 \times 37 \times 4$

[b]  $5 \times (20 + 15)$

(26) Calculate the perimeter of the opposite figure where  $AM = 7$  cm. ( $\pi = \frac{22}{7}$ )

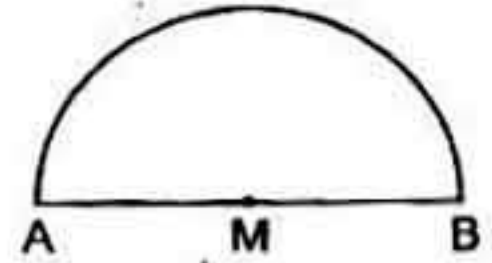

(27) If the number  $x$  exceeds twice the number  $y$  by 7 , write down the mathematical relation which relates  $x$  by  $y$

(28) By using the distribution property find :  $37 \times 46 + 37 \times 54$

(29) If the age of a man now is  $2x$  years where  $x \in \mathbb{N}$  Find :

[a] The age of the man after 6 years .....

[b] The age of the man since 3 years .....

(30) The following table the recorded temperature in 40 cities on day :

Temperature	20 –	22 –	24 –	26 –	28 –
No. of cities	7	10	12	6	5

[a] Draw each of histogram and frequency polygon.

[b] What is the number of cities their temperatures are less than 24 ?

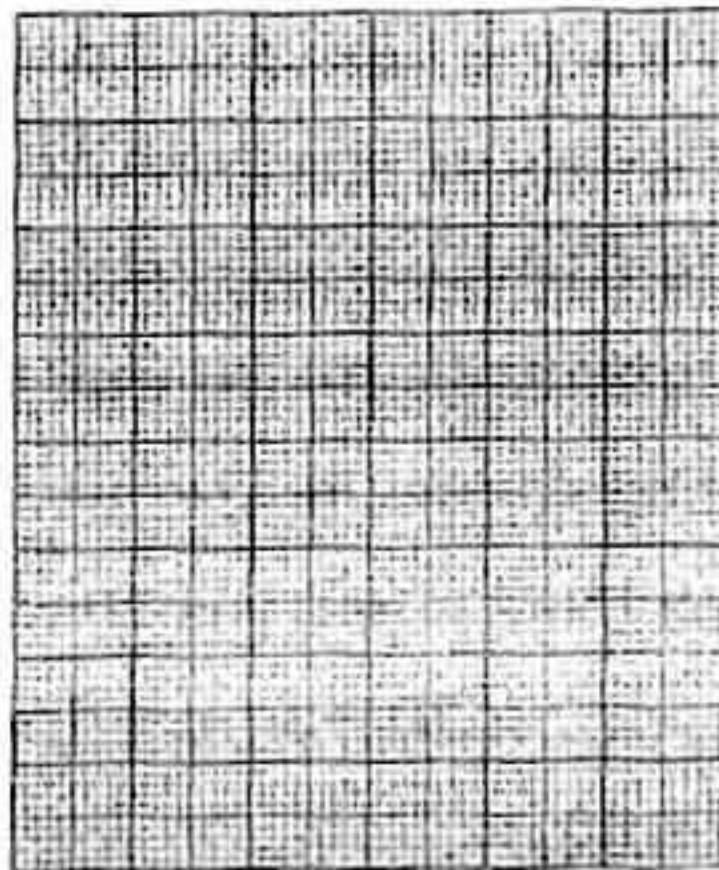



Answer the following questions :

1 Choose the correct answer :

- (1) If  $x$  is an even number , then  $x + 2$  is ..... number.  
( even or odd or prime or otherwise )
- (2) The radius length of a circle whose circumference is  
88 cm. = ..... cm. ( $\pi = \frac{22}{7}$ ) ( 28 or 21 or 14 or 7 )
- (3) The isosceles trapezium has ..... line(s) of symmetry.  
( 4 or 3 or 2 or 1 )
- (4) If the area of a square is  $50 \text{ cm}^2$  , then the length of its diagonal  
is ..... cm. ( 7 or 8 or 9 or 10 )
- (5) If  $a = 3$  ,  $b = 5$  , then  $4a - 2b =$  ..... ( 2 or 5 or 14 or 22 )
- (6) If  $x + 3 = 8$  ,  $x \in \mathbb{N}$  , then  $2x =$  .....  
( 11 or 24 or 5 or 10 )
- (7)  $37 \times 100 - 37 \times$  ..... =  $37 \times 15$  ( 115 or 75 or 85 or 63 )
- (8) The number of altitudes of the triangle is .....  
( 1 or 2 or 3 or 4 )
- (9)  $(8 - 8) \dots \mathbb{N}$  (  $\in$  or  $\notin$  or  $\subset$  or  $\not\subset$  )
- (10) 7 is subtracted from double of  $x =$  .....  
(  $7 - 2x$  or  $2x - 7$  or  $2 - 7x$  or  $7 + 2x$  )
- (11) The base length of a triangle is 8 cm. and its height is 5 cm. , then  
its surface area = .....  
( 20 cm. or  $20 \text{ cm}^2$  or 40 cm. or  $40 \text{ cm}^2$  )
- (12) The smallest counting number is ..... ( 0 or 1 or 2 or 3 )
- (13) If the sum of two numbers  $x$  and  $y$  is 20 , then  $y =$  .....  
(  $20 + x$  or  $20 - x$  or  $x - 20$  or  $\frac{x}{20}$  )
- (14)  $(4 \times \dots) \times 78 = 7800$  ( 5 or 10 or 25 or 50 )



**2 Complete each of the following :**

(15) The area of the rhombus =  $\frac{1}{2} \times$  the product of .....

(16) If A (2 , 3) , B (2 , 7) , then the midpoint of  $\overline{AB}$  is .....

(17) If the number  $x$  is 9 more than twice  $y$  , then  $x =$  .....

(18) The opposite transformation is .....  

(19) If A , B , C are natural numbers , then  $(A \times B) \times C = A \times (B \times C)$  is called ..... property.

(20) If the perimeter of a rectangle is 20 cm. , its length is  $x$  , then its width is .....

**3 Answer the following :**

(21) Write in the list method the set :  $X = \{x : x \in \mathbb{N} , 1 < x \leq 7\}$  , then represent its elements on the number line.

.....

(22) Use the properties of addition to find the result of the following :

$82 + 75 + 18 + 25$

.....

(23) Which is greater in area ?

A rhombus the lengths of its diagonals are 8 cm. and 6 cm. or a parallelogram in which the lengths of its base is 10 cm. and the corresponding height is 5 cm.

.....

أكتب ذاكرولي في البحث وانضم لجروبات ذاكرولي  
من الصف الأول للصف السادس الابتدائي



## Final Examinations

- (24) In the cartesian coordinate plane determine the following points A (6 , 6) , B (6 , 2) , C (1 , 2) and D (1 , 6) , then complete :
- [a] The name of the figure ABCD is .....
- [b] The length of  $\overline{CD}$  is .....

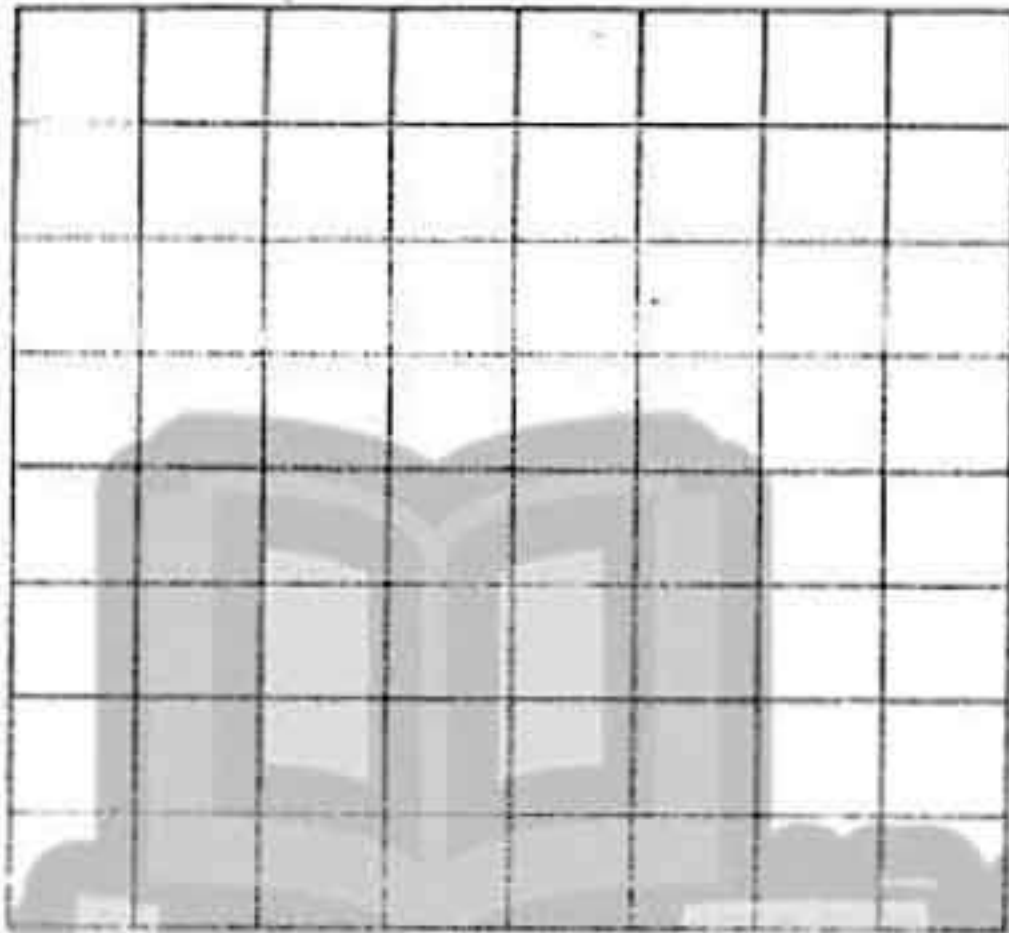

- (25) If  $X = \{x : x \in \mathbb{N}, 1 \leq x \leq 8\}$  ,  $Y = \{2, 4, 9\}$  , find :

[a]  $X \cup Y$

[b]  $X \cap Y$

[c]  $X - Y$

- (26) Solve the equations in  $\mathbb{N}$  :

[a]  $3x + 7 = 19$

[b]  $2y \div 5 = 10$

- (27) If the diameter length of the wheel of a bicycle is 50 cm.  
How long is the distance covered by the bicycle in meter if it turns 1200 turns ? ( $\pi = 3.14$ )

- (28) Use the operations properties in  $\mathbb{N}$  to find :

[a]  $8 \times 12 \times 125$

[b]  $231 \times 71 - 31 \times 71$



(29) If  $L$  is the axis of reflection of the  $\triangle ABC$ , draw  $\triangle A'B'C'$  the image of  $\triangle ABC$  by reflection in  $L$ .

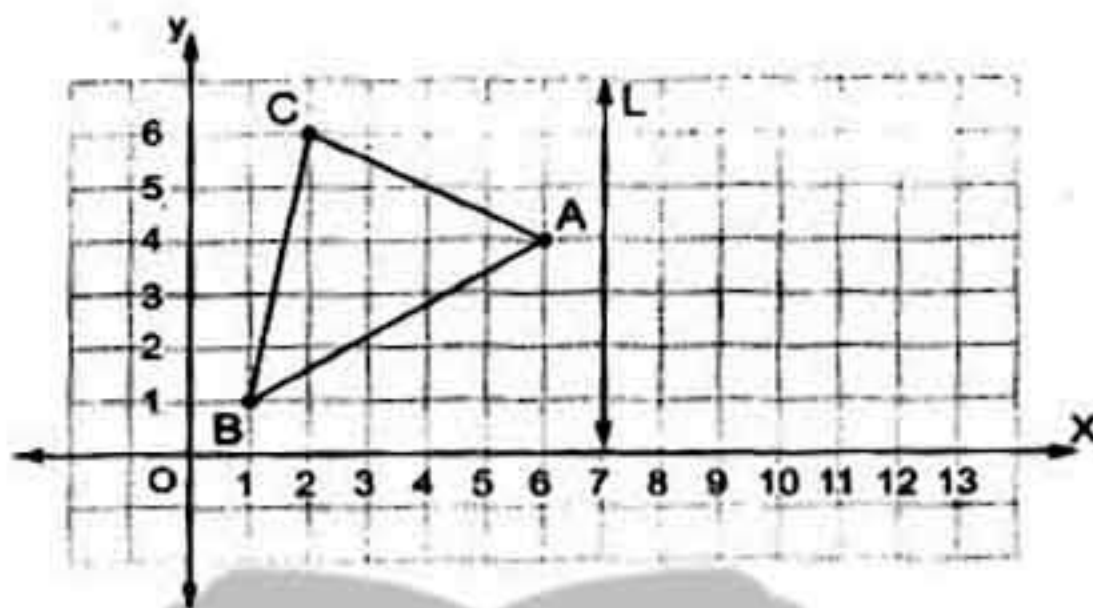

(30) The following table shows the frequency distribution of the number of work hours of 50 workers :

Sets	10 –	20 –	30 –	40 –	Total
Frequency	12	8	16	14	50

Draw the frequency polygon which represent these data.

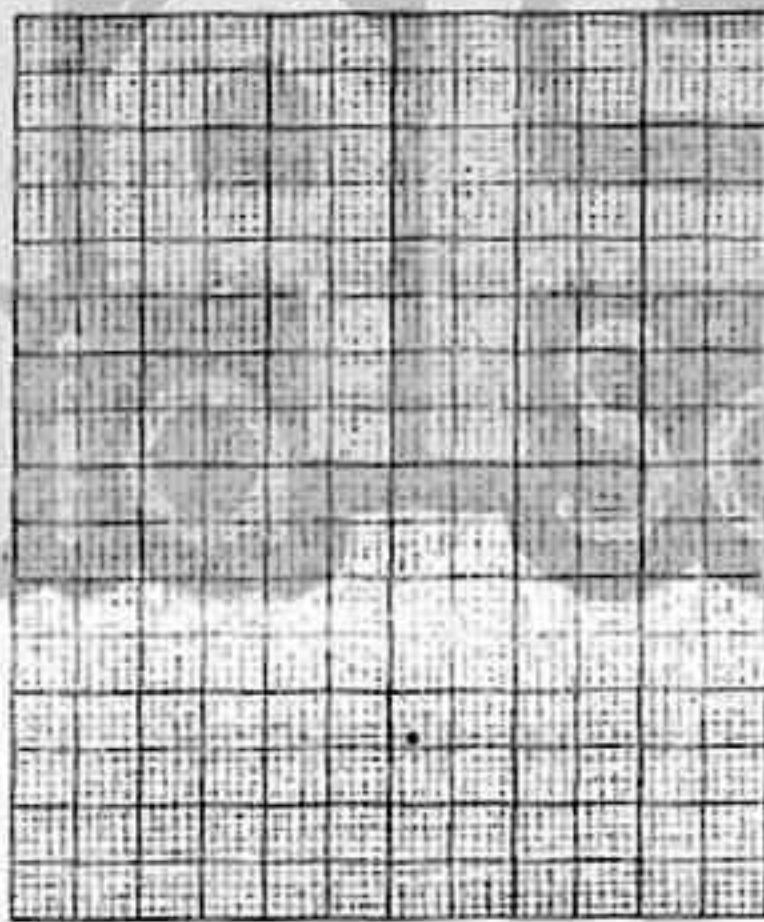

Model

16

Answer the following questions :

تابع جید ذاکرولی علی موقعنا  
<https://www.zakrooly.com>

1 Choose the correct answer :

(1) If  $3x = 6$ ,  $x \in \mathbb{N}$ , then  $5x - 1 = \dots\dots\dots$  (4 or 6 or 7 or 9)

(2) If  $a = 1$ ,  $b = 2$ , then  $5ab = \dots\dots\dots$  (10 or 11 or 13 or 20)



## Final Examinations

- (3) The isosceles triangle has ..... line(s) of symmetry.  
(0 or 1 or 2 or 3)
- (4) The area of rhombus whose diagonals lengths are 12 cm.  
and 16 cm. = ..... cm<sup>2</sup> (56 or 28 or 96 or 129)
- (5)  $\{2, 3\}$  .....  $\mathbb{N}$  ( $\in$  or  $\notin$  or  $\subset$  or  $\not\subset$ )
- (6) The area of a square whose diagonal length is 14 cm. = ..... cm<sup>2</sup>  
(196 or 98 or 56 or 158)
- (7) The length of the base of a triangle whose area is 120 cm<sup>2</sup> and its  
height is 10 cm. is ..... cm. (2 or 6 or 12 or 24)
- (8) The additive neutral element in  $\mathbb{N} \times$  the multiplicative neutral  
element in  $\mathbb{N} =$  ..... (3 or 2 or 1 or 0)
- (9) If the product of two numbers a and b is 15, then b = .....  
(15a or  $\frac{a}{15}$  or  $\frac{15}{a}$  or a + 15)
- (10) If the radius length of a circle is 20 cm., then its circumference  
= ..... cm. (10 $\pi$  or 20 $\pi$  or 40 $\pi$  or 80 $\pi$ )
- (11) Adding 5 to three times a number y is .....  
(5  $\times$  3y or 5 - 3y or 3y - 5 or 3y + 5)
- (12) If b = 3, then 2b - 1 = ..... (6 or 5 or 4 or 3)
- (13)  $\{7, 9.2\}$  .....  $\mathbb{N}$  ( $\in$  or  $\notin$  or  $\subset$  or  $\not\subset$ )
- (14) If  $7y = 2x + 3$ , then the constant is ..... (y or 7 or 2 or 3)

## 2 Complete each of the following :

- (15) If  $735 = (x \times 100) + 35$ , then x = .....
- (16) The set of natural numbers less than 7 and greater than 2 is .....
- (17)  $21 + (36 + \dots) = (21 + \dots) + 84$
- (18) 99 added to the neutral element of multiplication = .....
- (19)  $1 \times 2, 2 \times 4, 3 \times 8, \dots, \dots$  (in the same pattern)
- (20) The area of a parallelogram = .....



**3 Answer the following :**

(21) In the two dimensions cartesian coordinates , determine the points

A (2 , 5) , B (5 , 2) , C (5 , 8) , then :

[a] Find the length of  $\overline{BC}$

[b] Draw its image by reflection across  $\overleftrightarrow{BC}$

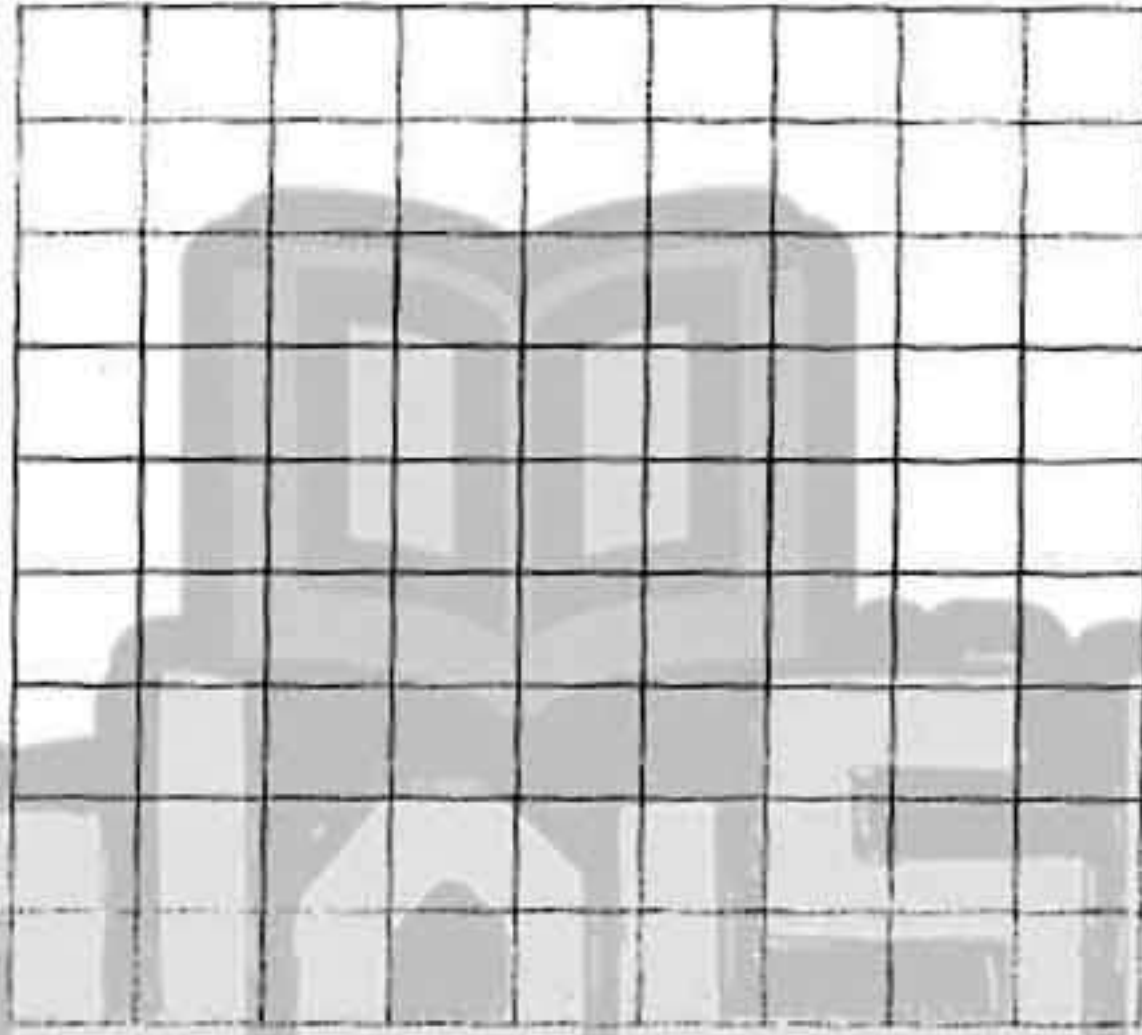

(22) Solve the following equation :  $5x - 7 = 33$  ,  $x \in \mathbb{N}$

(23) Use the properties of operation in  $\mathbb{N}$  to find the result of :

[a]  $26 \times 999$

[b]  $321 + 627 + 179 + 373$

(24) Calculate the perimeter of the opposite figure where  $AB = 7$  cm. ,  $BC = 9$  cm. and  $AC = 8$  cm. ( $\pi = \frac{22}{7}$ )

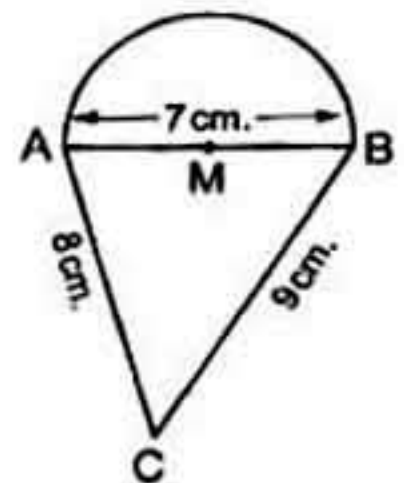



## Final Examinations

(25) Which is smaller in area ?

a square of side length 12 cm. or a rhombus with diagonal 20 cm. and 14 cm.

.....

.....

(26) Using the properties of commutative , distributive and associative to find the value of :  $4 \times 31 \times 25$

.....

(27) Ahmed has L.E.  $x$  , Samir has L.E. 10 and the sum of what Samir has twice of what Ahmed has is L.E. 24 Write the equation that represents this situation and find the value of  $x$

.....

(28) Solve the following equation in  $\mathbb{N}$  :  $\frac{1}{2}x + 8 = 10$

.....

(29) If  $a = 5$  ,  $b = 3$  ,  $c = 1$  , then find :

[a]  $a \times b - c$

[b]  $\frac{a - c}{b}$

.....

(30) Use the histogram and frequency polygon to represent the data and find the value of A :

Sets	10 -	20 -	30 -	40 -	50 -	Total
Frequency	5	7	12	A	7	40

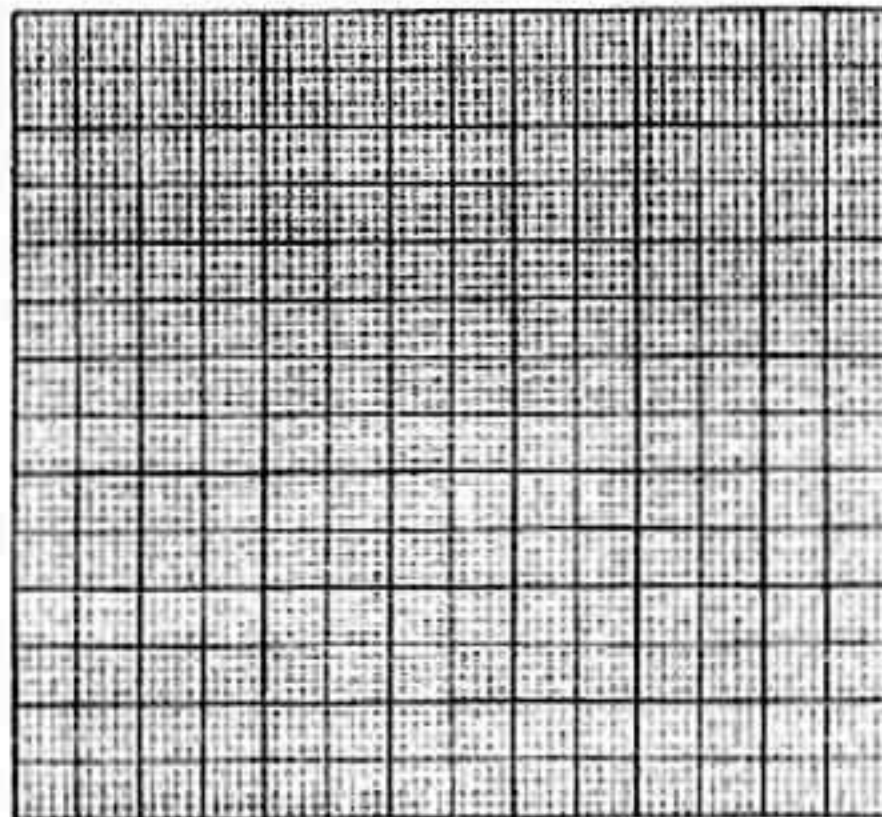



## Model 17

Answer the following questions :

1 Choose the correct answer :

(1) The opposite geometric transformation is .....   
( rotation or translation or reflection )

(2) The value of :  $10 - 2h$  when  $h = 3$  equals .....  
( 5 or 4 or 7 or 16 )

(3) A circle of radius length 7 cm. , its circumference = ..... cm. ( $\pi = \frac{22}{7}$ )  
( 22 or 44 or 60 or 14 )

(4) The square whose diagonal length 10 cm. , then its area = .....  $\text{cm}^2$   
( 100 or 50 or 200 or 25 )

(5) Four times of a number  $y$  is represented by .....  
(  $y + 4$  or  $4y$  or  $y - 4$  or  $\frac{y}{4}$  )

(6)  $12 \times 7 = 7 \times$  ..... ( 12 or 7 or 84 or 5 )

(7) 1 , 1 , 2 , 3 , 5 , 8 , ..... (in the same pattern)  
( 9 or 11 or 13 or 40 )

(8)  $(5 - 8) \dots \mathbb{N}$  ( $\in$  or  $\notin$  or  $\subset$  or  $\not\subset$ )

(9) The number of axes of symmetry of the rhombus = .....  
( 0 or 1 or 2 or 3 )

(10) The sum of two odd numbers is ..... number.  
( even or odd or prime or otherwise )

(11)  $215 + 53 = 53 + 215$  is called ..... property.  
( commutative or closure or associative )

(12) If  $y + 3 = 7$  , then  $y + 1 =$  ..... ( 4 or 3 or 5 or 6 )

(13) The area of the rhombus whose side length is 8 cm. and its height is 4 cm. equals .....  $\text{cm}^2$  ( 12 or 16 or 32 or 64 )

(14) For  $a \in \mathbb{N}$  ,  $b \in \mathbb{N}$  , then  $a \times b \dots \mathbb{N}$  ( $\in$  or  $\notin$  or  $\subset$  or  $\not\subset$ )



## Final Examinations

## 2 Complete each of the following :

(15) In the opposite figure :

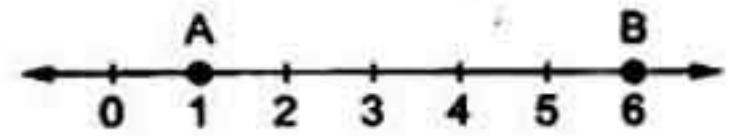
The length of  $\overline{AB}$  = ..... length units.(16) If  $x \times 4 + x \times 60 = 3 \times 64$  , then  $x =$  .....

(17) In the opposite figure :

$\triangle BEF$  is the image of  $\triangle BDF$   
by reflection across .....

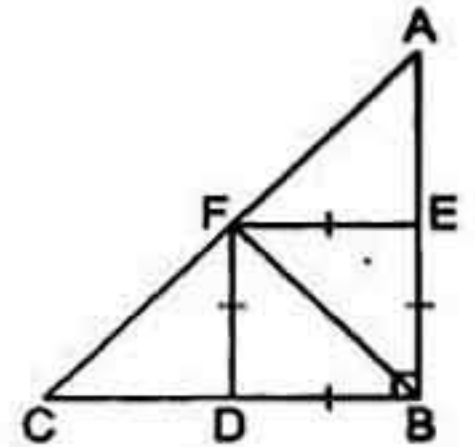
(18) If  $(x, 1) = (4, y)$  , then  $x =$  ..... ,  $y =$  .....(19) If the difference between two numbers is 5 , the smaller number is  $y$  , then the greater number is .....(20) If  $X = \{x : x \in \mathbb{N}, 2 \leq x \leq 5\}$  , then  $X =$  .....

## 3 Answer the following :

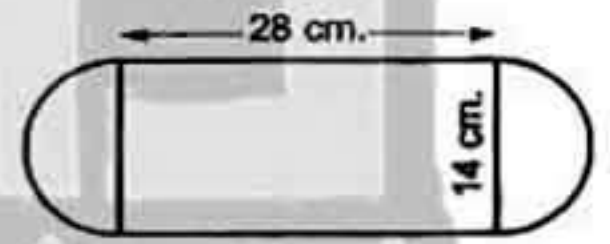
(21) Calculate the perimeter of the opposite figure. ( $\pi = \frac{22}{7}$ )(22) Use property of commutative and associative in  $\mathbb{N}$  to find the result of :  $8 \times 34 \times 125$ (23) Solve the following equation when  $x \in \mathbb{N}$  :

$$3x - 6 = 12$$



- (24) In the two dimensions coordinates , draw  $\triangle ABC$  where  $A(4, 2)$  ,  $B(4, 5)$  ,  $C(7, 2)$  , then find its image by reflection across  $\overline{AB}$  and find the length of  $\overline{AB}$

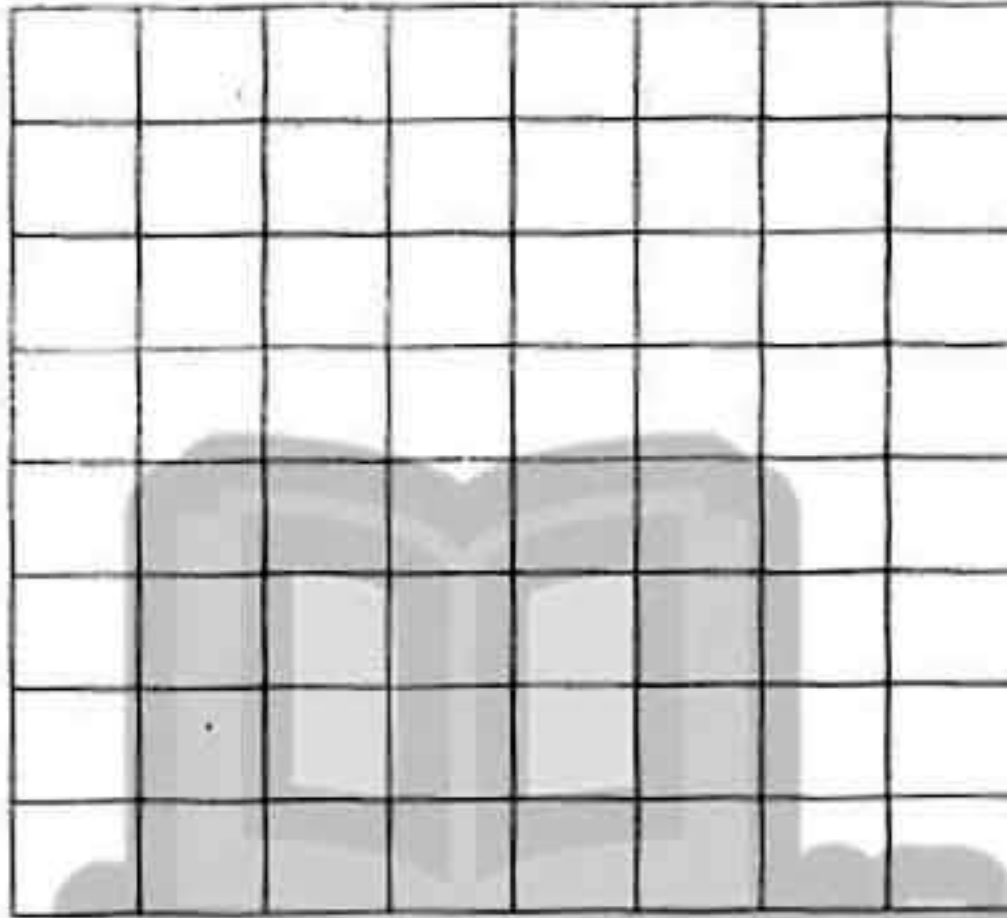

- (25) Find the area of the triangle whose base length is 12 cm. and height is 8 cm.
- .....

- (26) If  $x$  is a prime number included between 1 and 6 , write down the values of  $x$
- .....

- (27) In the opposite figure :  
 ABCD is a parallelogram in which  
 $BC = 14$  cm. ,  $BE = 6$  cm.  
 ,  $M$  is the midpoint of  $\overline{AD}$  , complete :

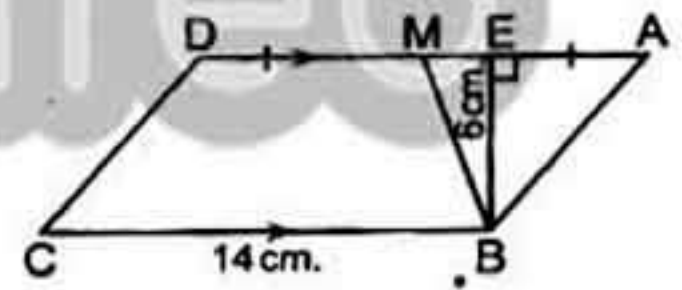

- [a]  $AD = \dots\dots\dots$  cm.                      [b]  $AM = \dots\dots\dots$  cm.  
 [c] The area of  $\square ABCD = \dots\dots\dots$   $\text{cm}^2$   
 [d] The area of  $\triangle ABM = \dots\dots\dots$   $\text{cm}^2$

- (28) Use the distributive property to find :  $299 \times 12$
- .....

- (29) Write down the representing set on the opposite number line :
- .....

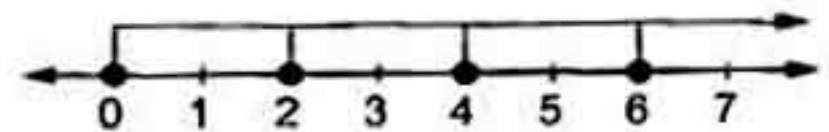



## Final Examinations

(30) The following data represents the marks in Arabic test for students in one classroom :

Sets	10 –	20 –	30 –	40 –	Total
Frequency	8	12	16	14	50

Draw the histogram for his distribution.

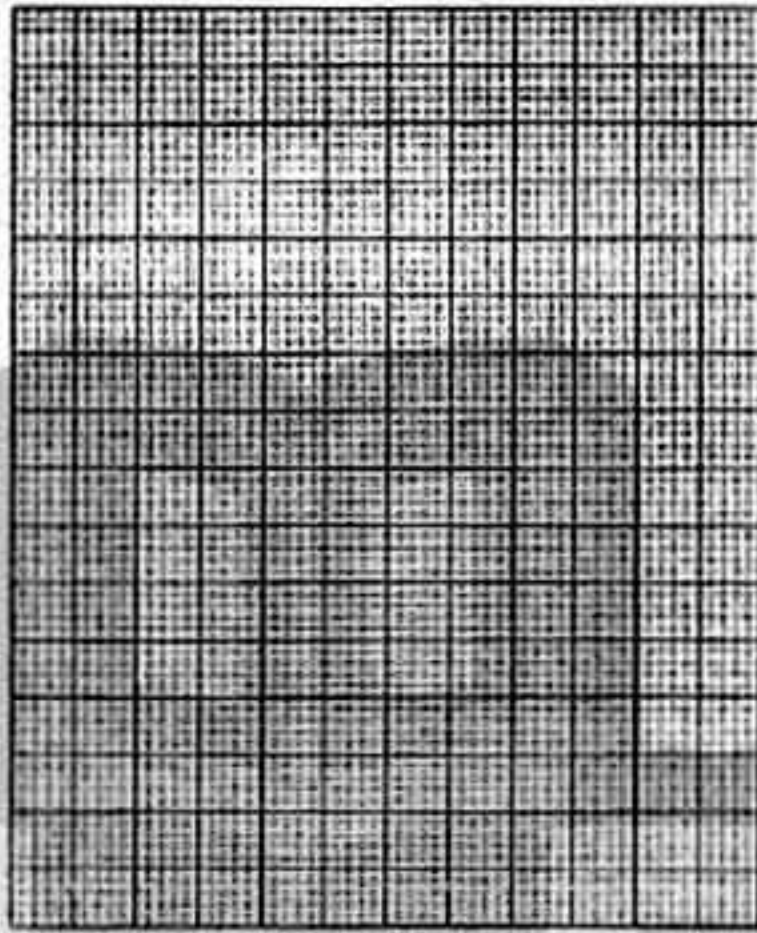

Model 18

Answer the following questions :

1 Choose the correct answer :

- (1) If  $X = \{a : a \in \mathbb{N}, 7 < a < 8\}$ , then  $X = \dots\dots\dots$   
 ( {7} or {8} or {7, 8} or  $\emptyset$  )
- (2)  $\dots\dots\dots = \frac{1}{2}$  the length of its diagonal  $\times$  itself. ( Area of triangle or Area of parallelogram or Area of square or Area of rhombus )
- (3) The circle in which the length of the greatest chord is 21 cm.  
 , its circumference =  $\dots\dots\dots$  cm. ( $\pi = \frac{22}{7}$ )  
 ( 35 or 14 or 44 or 66 )
- (4) The set of even numbers  $\cup$  the set of odd numbers =  $\dots\dots\dots$   
 ( E or O or  $\emptyset$  or  $\mathbb{N}$  )
- (5)  $(x - 15) \dots\dots\dots (x - 14)$  where  $x$  is a natural number more than 17  
 ( > or < or = or  $\geq$  )
- (6) The difference between three times a number  $x$  and two is  $\dots\dots\dots$   
 (  $3x + 2$  or  $3x - 2$  or  $3 \times 3x$  or  $\frac{3x}{2}$  )



(7) If  $\frac{1}{7}x - 3 = 2$ ,  $x \in \mathbb{N}$ , then  $x = \dots\dots\dots$  (5 or 12 or 2 or 35)

(8) The circumference of a circle  $+ r = \dots\dots\dots$

( $\pi$  or  $2\pi$  or  $\frac{\pi}{2}$  or  $\frac{1}{2}$ )

(9) The area of the largest rectangle whose perimeter is 24 cm.

=  $\dots\dots\dots$  cm<sup>2</sup>

(32 or 36 or 72 or 144)

(10) The number of axes of symmetry of the equilateral triangle is  $\dots\dots\dots$

(1 or 2 or 3 or 4)

(11) The area of a parallelogram in which the length of the base is 10 cm. and its height is 5 cm. equals  $\dots\dots\dots$  cm<sup>2</sup>

(15 or 25 or 50 or 100)

(12) Which of the following geometric transformation represents the reflection ?



(13) The base length of a triangle whose area is 120 cm<sup>2</sup> and its height is 5 cm. equals  $\dots\dots\dots$  cm.

(12 or 24 or 48 or 96)

(14)  $\{\frac{1}{3}, 1, 2\} \dots\dots\dots \mathbb{N}$

( $\in$  or  $\notin$  or  $\subset$  or  $\not\subset$ )

### 2 Complete each of the following :

(15) The set of natural numbers less than 7 is  $\dots\dots\dots$

(16)  $91 \times (73 + 27) = 91 \times \dots\dots\dots = \dots\dots\dots$

(17) If the side length of a square is 5 cm. , then its area =  $\dots\dots\dots$  cm<sup>2</sup>

(18) If  $x$  is an odd number , then  $x + 2$  is an  $\dots\dots\dots$  number.

(19) 2 , 7 , 12 , 17 ,  $\dots\dots\dots$  ,  $\dots\dots\dots$  (in the same pattern)

(20) If  $37 + 73 = 73 + 37$  , then its is called  $\dots\dots\dots$  property.

### 3 Answer the following :

(21) The lengths of the diagonals of a rhombus are 30 cm. and 20 cm.  
Calculate its area.

$\dots\dots\dots$



## Final Examinations

(22) Solve the following equations such that  $x \in \mathbb{N}$  :

[a]  $x - 4 = 1$

[b]  $3x + 8 = 29$

.....

.....

(23) In a coordinate plane , draw  $\Delta ABC$  where A (2 , 3) , B (5 , 3) and C (5 , 7) , then draw the image of  $\Delta ABC$  by reflection across  $\overline{BC}$

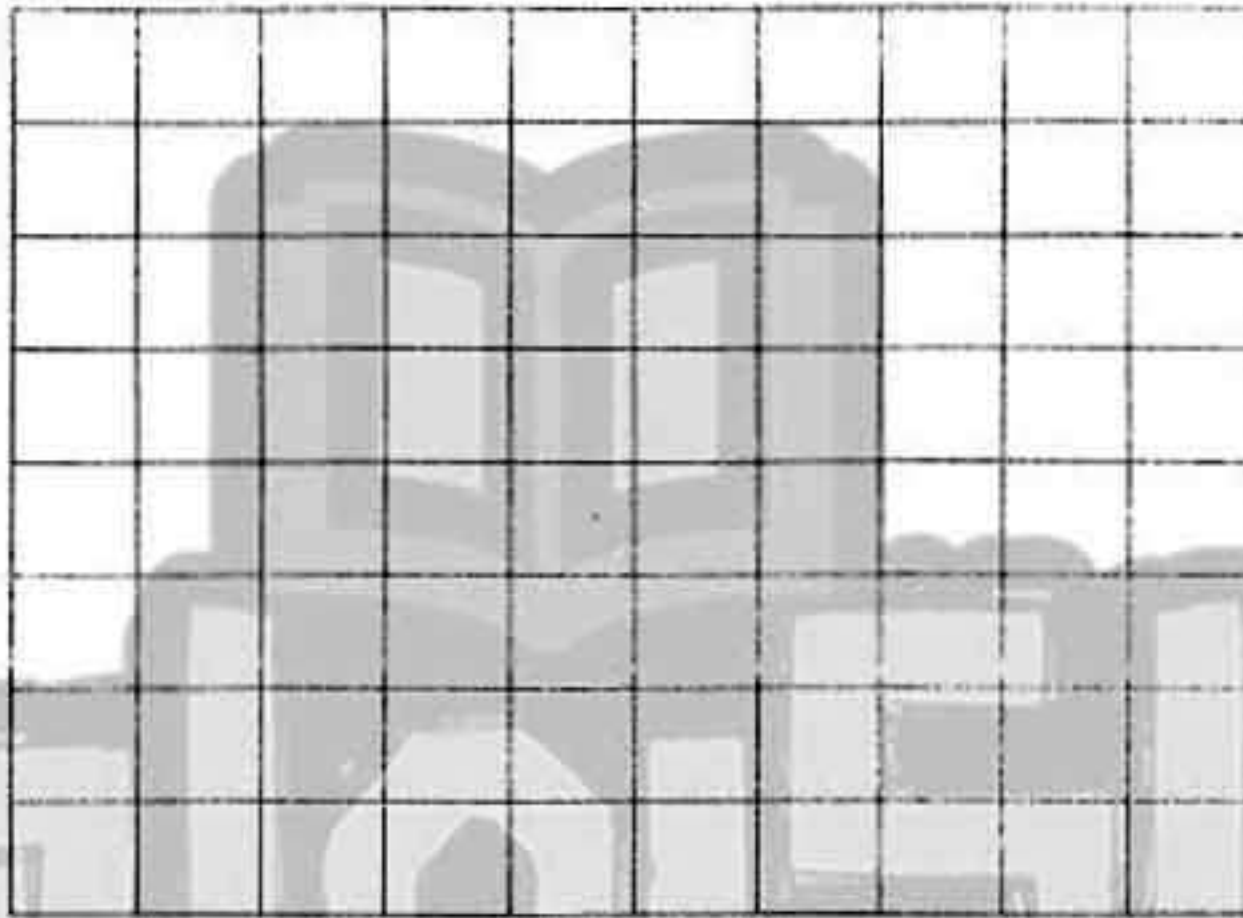

(24) Using the operation properties to find the value of :

[a]  $8 \times 135 \times 125$

[b]  $56 \times 42 - 56 \times 32$

.....

.....

(25) If  $X = \{x : x \in \mathbb{N}, 3 \leq x \leq 8\}$  ,  $Y = \{1, 3, 5\}$  , find :

[a]  $X \cap Y$

[b]  $X \cup Y$

[c]  $Y - X$

.....

(26) The following table shows the number of students who practice sports. Represent these data using pie graph on the opposite figure :

Game	Football	Basketball	Volleyball
Number	20	10	10

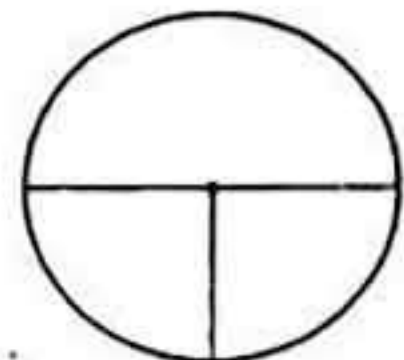



(27) Translate the statement into an equation :

If 9 is subtracted from a number , then the result is 23

.....

(28) Find the perimeter of the opposite figure :

.....

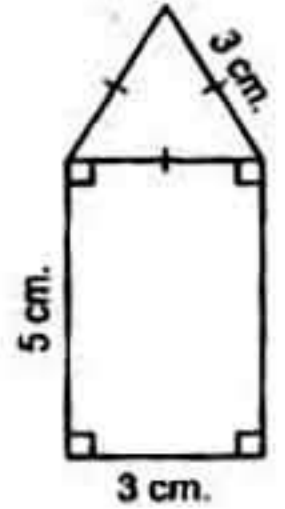

(29) Use the distribution property in  $\mathbb{N}$  to find :  $319 \times 101$

.....

(30) The following table shows the marks of 35 students in math exam :

Sets	5 -	10 -	15 -	20 -	25 -	Total
Frequency	5	9	k	6	4	35

[a] Find the value of k

[b] Represent these data by a frequency polygon.

Model 19

Answer the following questions :

1 Choose the correct answer :

( 1 ) The ..... triangle has one line of symmetry.

( equilateral or isosceles or scalene )

( 2 ) The sum of the two numbers  $x$  and  $y$  is 10 , then  $y =$  .....

(  $x - 10$  or  $10 - x$  or  $x$  or 10 )

( 3 ) The area of triangle whose base length 5 cm. and the corresponding height 6 cm. is .....  $\text{cm}^2$

( 60 or 15 or 11 or 3 )

( 4 ) If  $x$  is an even number , then  $x - 1$  is an ..... number.

( even or odd or prime or otherwise )



## Final Examinations

- (5) The area of square of diagonal length 6 cm, is .....  $\text{cm}^2$   
(18 or 36 or 24 or 6)
- (6) If  $x - 2 = 4$ , then  $x + 1 =$  .....  
(6 or 3 or 7 or 5)
- (7)  $99 \times$  the multiplicative neutral element in  $\mathbb{N} =$  .....  
(0 or 99 or 100 or 1)
- (8) If the ordered pair  $(x, y) = (3, 1)$ , then  $y =$  .....  
(3 or 1 or 2 or 4)
- (9) The perimeter of equilateral triangle whose side is  $x$  cm. = ..... cm.  
( $3 + x$  or  $x - 3$  or  $3x$  or  $\frac{x}{3}$ )
- (10) A circumference of a circle is 22 cm., then its radius length  
= ..... cm. where  $\pi = \frac{22}{7}$  (3.5 or 7 or 8 or 11)
- (11) The sum of two natural numbers .....  $\mathbb{N}$   
( $\in$  or  $\notin$  or  $\subset$  or  $\not\subset$ )
- (12)  $(8 \times 3) \times 5 =$  .....  $\times (3 \times 5)$  (3 or 5 or 8 or 35)
- (13) The geometric transformation  is .....  
(translation or rotation or reflection)
- (14)  $8 \times 54 =$  ..... ( $8 \times 5 + 8 \times 4$  or  $8 \times 5 + 8 \times 40$  or  $8 \times 50 + 8 \times 4$ )

## 2 Complete each of the following :

- (15) The missing number in the pattern :  
1, 4, 16, 64, ....., 1024, 4096 is .....
- (16) If A (2, 3), B (7, 3), then AB = ..... length units.
- (17)  $273 \times 53 +$  .....  $\times 273 = 273 \times 100$
- (18)  $64 + (36 + \dots) = (64 + \dots) + 35 = \dots + 35 = \dots$
- (19) The rhombus whose area is  $36 \text{ cm}^2$  and the length of one of its diagonals is 8 cm., the length of the other diagonal = ..... cm.
- (20) The set of the natural numbers which are more than 4 and less than 5 is .....



**3 Answer the following :**

(21) The lengths of two adjacent sides in a parallelogram are 6 cm. and 8 cm. If its greater height is 4 cm. , then find its smaller height.

.....

(22) Using the properties of addition find the value :

$$32 + 47 + 68 + 3$$

.....

(23) In the opposite figure :

ABC is a right-angled triangle at A ,  $\overline{AD} \perp \overline{BC}$

Find the area of  $\Delta ABC$  and the length of  $\overline{AD}$

.....

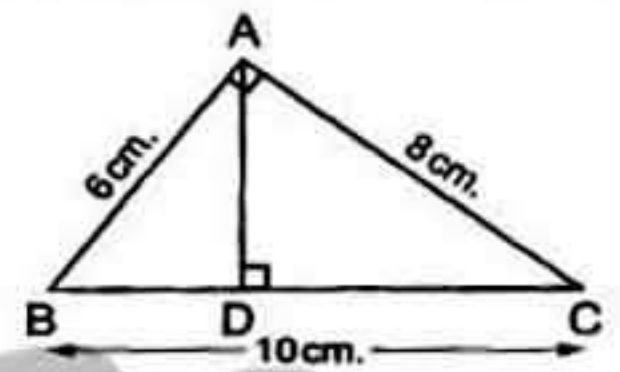

(24) Represent each set of the following on the number line :

[a]  $\{0, 1, 3, 4\}$

[b]  $\{1, 2, 4\} \cup \{1, 3, 4, 5\}$

.....

(25) In a 2-dimensional coordinate plane , locate the points A (2 , 0) , B (6 , 0) , C (6 , 4) and D (2 , 4) , then name the shape ABCD and find its area.

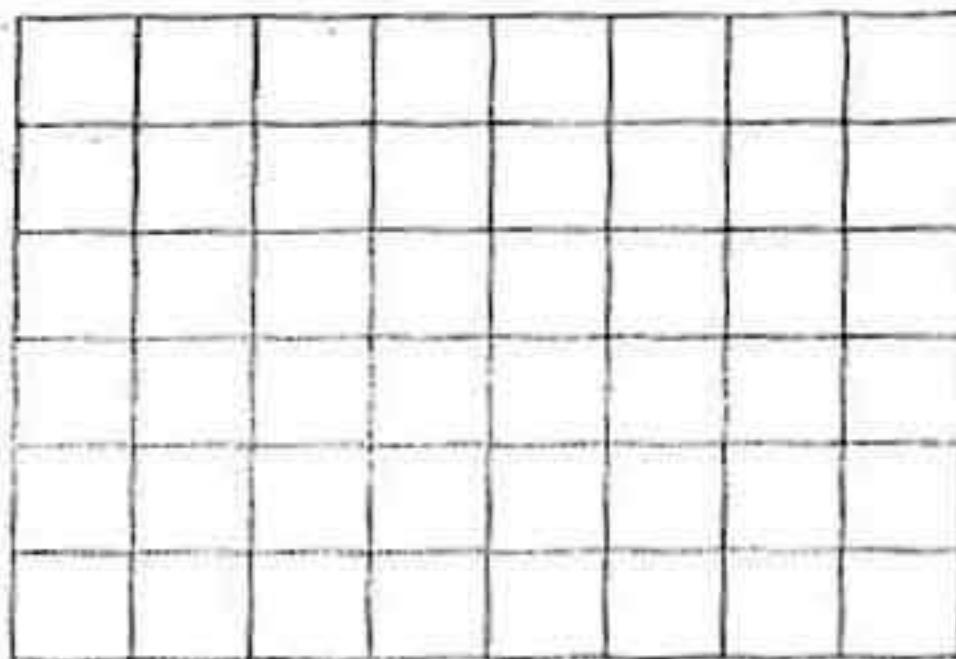



## Final Examinations

(26) The product of a number  $k$  and 7 is 56 , find the number  $k$

(27) Draw the image of the following figure by reflection across  $L$  :

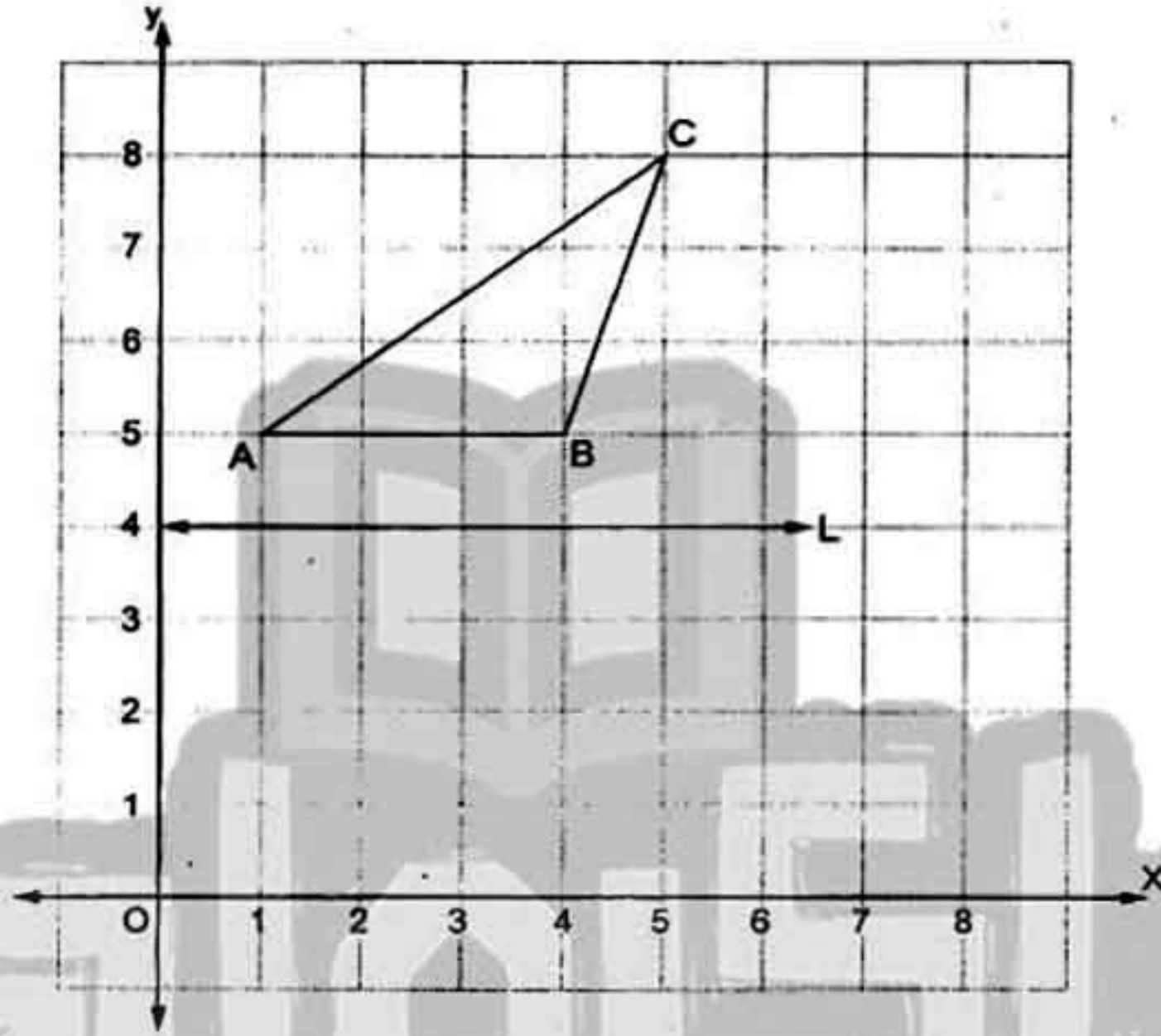

(28) Solve the equations in  $\mathbb{N}$  :

[a]  $5x - 7 = 33$

[b]  $4 + x = 18$

(29) Use the distributive property to find the value of :  $16 \times 999 \div 16$

(30) The following table represents the marks of 50 students in a maths exam in a month , where the full mark is 50 :

Sets	10 -	20 -	30 -	40 -	Total
Frequency	10	12	18	10	50

[a] Draw the frequency polygon which represents the given data.

[b] Find the number of students who got 30 marks or more.



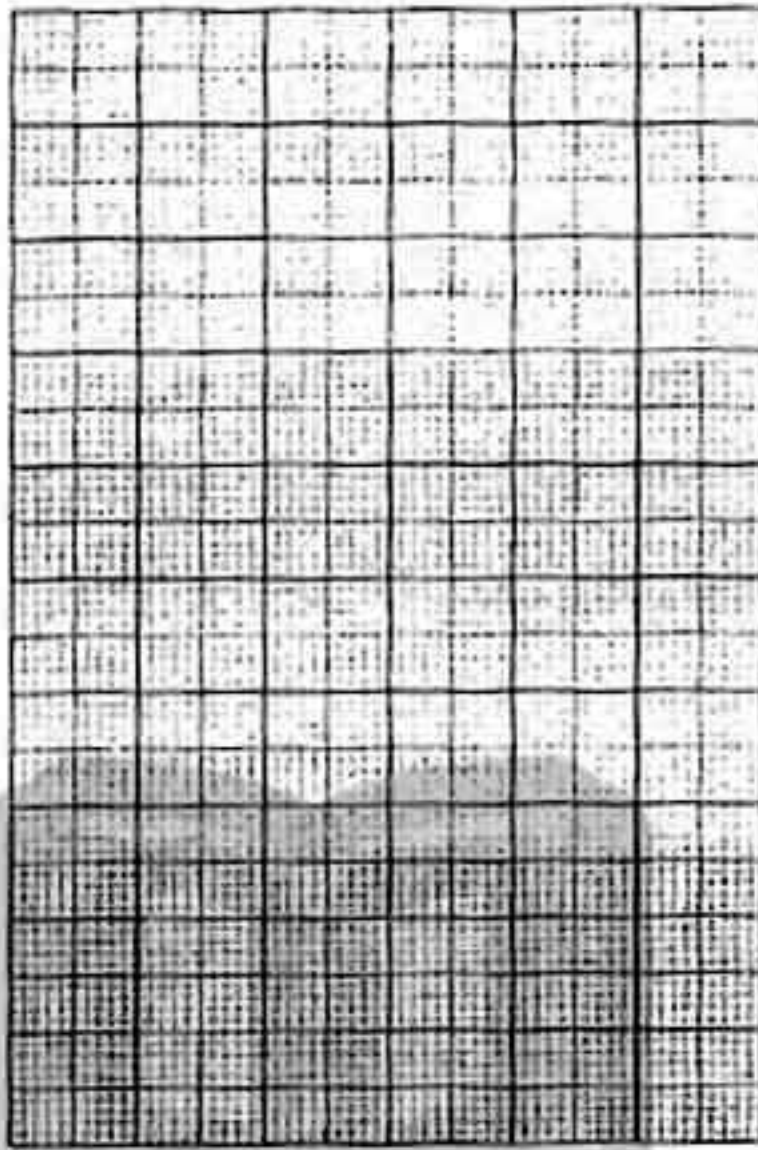

## Model 20

Answer the following questions :

1 Choose the correct answer :

- (1) If  $\mathbb{N}$  is the set of natural numbers ,  $a \in \mathbb{N}$  ,  $b \in \mathbb{N}$   
 , then  $a \times b \dots\dots\dots \mathbb{N}$  ( $\in$  or  $\notin$  or  $\subset$  or  $\not\subset$ )
- (2)  $5 \times (100 - \dots\dots\dots) = 5 \times 98$  (1 or 2 or 98 or 0)
- (3) The area of rhombus whose diagonals are 5 cm. and 8 cm.  
 =  $\dots\dots\dots$  cm<sup>2</sup> (40 or 20 or 26 or 13)
- (4) If  $x + 4 = 10$  , then  $2x = \dots\dots\dots$  (14 or 6 or 12 or 24)
- (5)  $\frac{0}{7} \dots\dots\dots \mathbb{N}$  ( $\in$  or  $\notin$  or  $\subset$  or  $\not\subset$ )
- (6) Twice of a number  $x$  subtracted from it 5 is  $\dots\dots\dots$   
 ( $x - 5$  or  $2x + 5$  or  $2x - 5$  or  $5x$ )
- (7) The number of axes of symmetry of the rectangle =  $\dots\dots\dots$   
 (0 or 1 or 2 or 3)
- (8) The circumference of a circle whose radius length 7 cm.  
 =  $\dots\dots\dots$  ( $\pi = \frac{22}{7}$ ) (11 or 22 or 44 or 88)
- (9) The additive neutral element in  $\mathbb{N}$  is  $\dots\dots\dots$  (0 or 1 or 3 or 5)



## Final Examinations

(10) If  $x = 2$  and  $y = 7$ , then  $\frac{2y}{x} = \dots\dots\dots$  ( 14 or 3 or 3.5 or 7 )

(11) If  $X = \{x : x \in \mathbb{N}, x < 3\}$ , then  $X = \dots\dots\dots$   
( {1, 2} or {2} or {0, 1, 2} or {0, 1, 2, 3} )

(12) If  $3a + 2b = 11$ , then the constant is  $\dots\dots\dots$   
( 3 or 2 or 11 or a )

(13) The opposite transformation  is  $\dots\dots\dots$   
( translation or reflection or rotation )

(14) The triangle whose base length is 3 cm. and its corresponding height is 4 cm. , its area =  $\dots\dots\dots$  cm. ( 14 or 7 or 6 or 12 )

**2 Complete each of the following :**

(15) The square whose perimeter is 32 cm. , its area =  $\dots\dots\dots$  cm<sup>2</sup>

(16) 1 , 4 , 8 , 13 ,  $\dots\dots\dots$  ,  $\dots\dots\dots$  (in the same pattern)

(17) Any even number  $\times$  any odd number =  $\dots\dots\dots$  number.

(18) If  $482 = x + (8 \times 10) + (4 \times 100)$ , then  $x = \dots\dots\dots$

(19) The set of prime numbers which are less than 10 is  $\dots\dots\dots$

(20) Ahmed had  $x$  pounds , he bought a pen for 3 pounds , now Ahmed has  $\dots\dots\dots$  pounds.

**3 Answer the following :**

(21) ABCD is a square , its perimeter is 60 cm. ,  $E \in \overline{BC}$  ,  $BE = 35$  cm.  
Find the area of the figure ABED

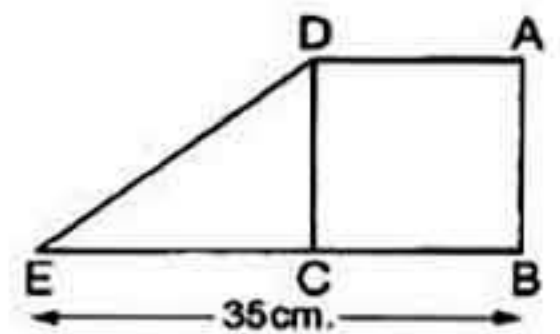

(22) Solve the equations in  $\mathbb{N}$  :

[a]  $22 = x + 10$

[b]  $\frac{1}{2}y + 1 = 3$



- (23) In the cartesian plane draw  $\triangle ABO$  in which  $A(3, 2)$ ,  $B(3, 5)$  and  $O(0, 0)$ , then draw its image by reflection in  $\overline{AB}$

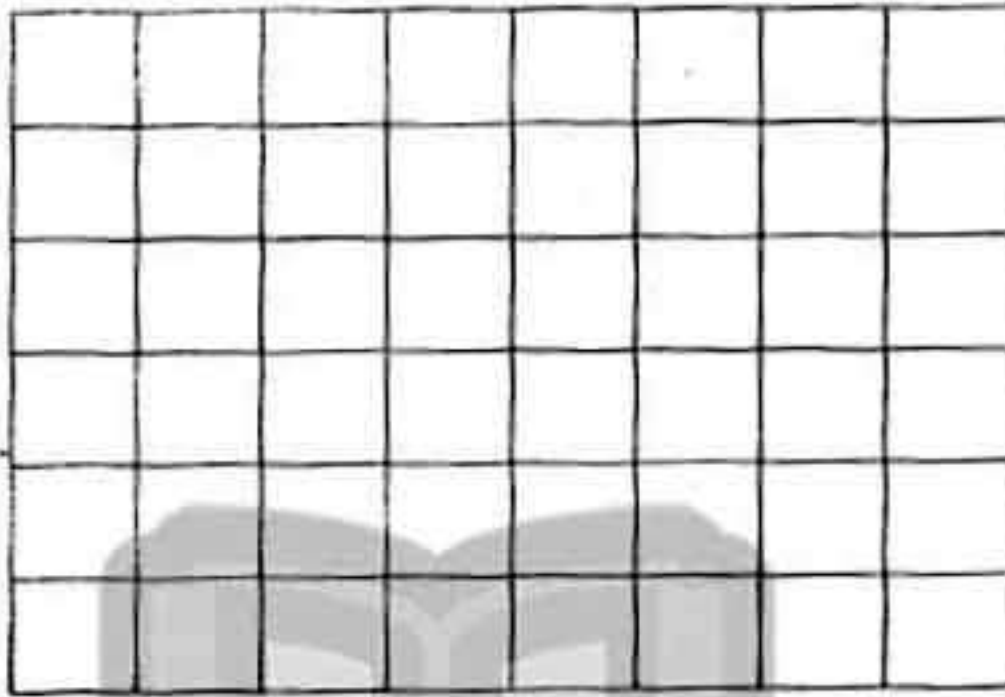

- (24) Find the seventh term in the sequence :

1, 3, 7, 15, 31, .....

- (25) Use the properties of the operations to find the result of :

[a]  $25 \times 31 \times 4$

[b]  $28 + 17 + 72 + 83$

.....  
 .....

- (26) In the opposite figure :

ABCD is a parallelogram in which

$AB = 10 \text{ cm.}$ ,  $DE = 12 \text{ cm.}$ ,  $DF = 8 \text{ cm.}$

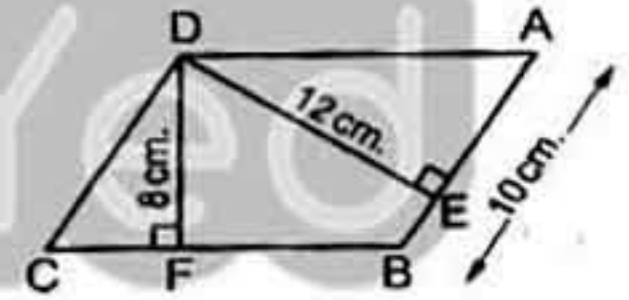

Find : [a] The area of the parallelogram ABCD

[b] The length of  $\overline{BC}$

.....  
 .....

- (27) Write the symbolic expression  $3h - 4$  in words.

.....

- (28) The area of a square is  $50 \text{ cm}^2$ , find the length of its diagonal.

.....



## Final Examinations

(29) Use the distribution property in  $\mathbb{N}$  to find :

$$47 \times 18 + 47 \times 82$$

(30) The following table shows the frequency distribution of the number of work hours of 50 workers :

Sets	4 –	6 –	8 –	10 –	Total
Frequency	12	8	16	14	50

Draw the frequency polygon which represents these data.

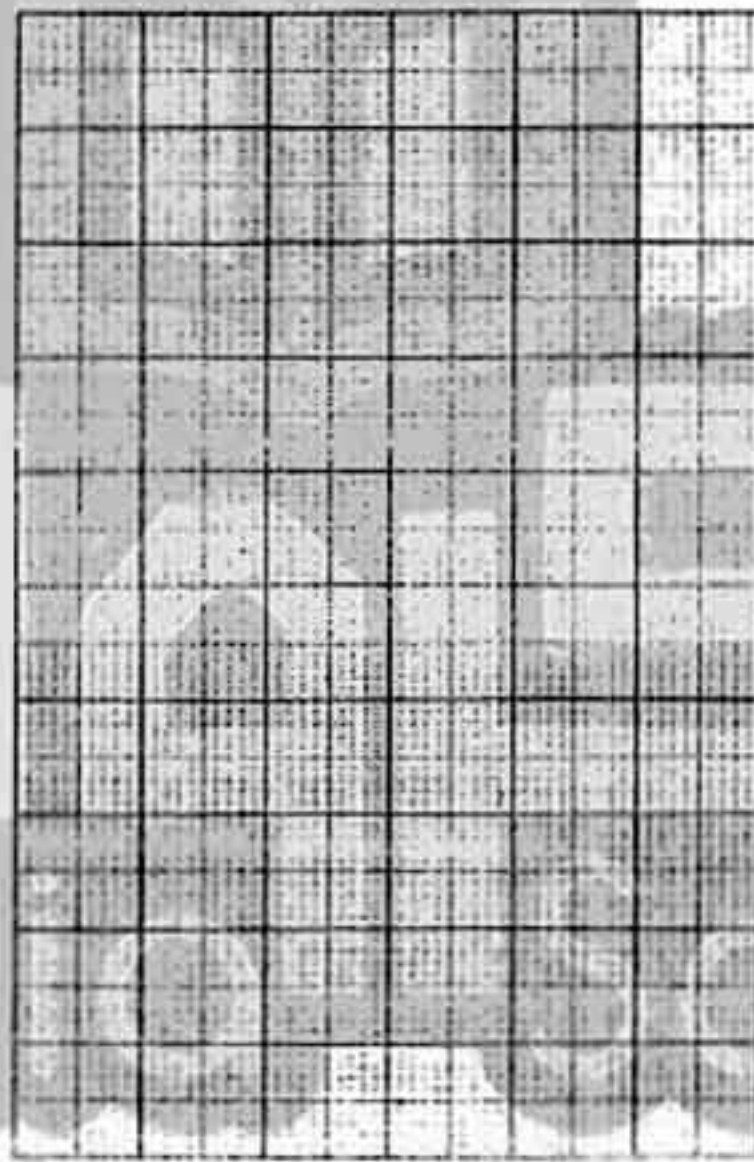

تفوقك في أي عمل عليه العلامة دي 

تابعنا على صفحتنا على الفيسبوك  [www.facebook.com/ZakroolySite](http://www.facebook.com/ZakroolySite)

تابع جديد زاكروولي على موقعنا  <https://www.zakrooly.com>





## Models of school book

## Model 1



Answer the following questions :

## 1 Circle the true answer :

- (a) The sum of two natural numbers .....  $\mathbb{N}$   
(  $\in$  or  $\notin$  or  $\subset$  or  $\varnothing$  )
- (b) If  $x + 3 = 5$ ,  $x \in \mathbb{N}$ , then  $x =$  ..... ( 1 or 2 or 3 or 4 )
- (c) The area of a rhombus whose diagonals lengths are 6 cm. and 8 cm. is .....  $\text{cm}^2$   
( 48 or 12 or 24 or 40 )

## 2 (a) Complete to make the sentence true :

- (1) The circumference of a circle with radius lengths 10 cm. is .....  $\pi$  cm.
- (2) For any natural numbers  $a$ ,  $b$  and  $c$  where  $(a \times b) \times c = a \times (b \times c)$  is called ..... property.
- (b) Which is greater in area : a square whose diagonal length is 10 cm. or a right angled triangle whose legs are 8 cm. and 15 cm. ?

3 Ahmed has L.E.  $x$ , Samir has L.E. 10 and the sum of what Samir has and the twice of what Ahmed has is L.E. 24, Write an equation to represent this situation and find the value of  $x$ .4 (a) In a 2-dimensional coordinate plane : Draw the triangle ABC where  $A(2, 1)$ ,  $B(5, 1)$  and  $C(5, 5)$ , then draw the image of the triangle ABC by reflection across  $\overline{BC}$  and find the sum of areas of the triangle and its image.

- (b) In the opposite figure : ABCD is a parallelogram, where  $AD = 12$  cm.,  $CD = 6$  cm.,  $DE = 5$  cm. and  $\overline{DE} \perp \overline{BC}$ . Find the area of the parallelogram, then calculate its height drawn from point D on  $\overline{AB}$ .

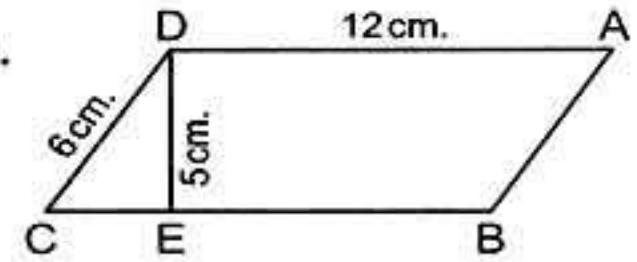
5 (b) Compare using  $>$ ,  $<$  or  $=$  :

- (1) The additive neutral element in  $\mathbb{N}$  ..... the multiplicative neutral element in  $\mathbb{N}$ .
- (2) The value of  $x$ , when  $x + 1 = 3$  ..... the value of  $x$  when  $2x = 6$



## Final Examinations

- (b) The following frequency table shows the marks of 35 students in the math exam. Graph these data using the frequency polygon.

Sets	5 –	10 –	15 –	20 –	25 –	Total
Frequency	5	9	11	6	4	35

## Model 2



Answer the following questions :

**1 Complete to get a true sentence :**

- (a) The area of a square =  $\frac{1}{2}$  the product of .....  $\times$  .....
- (b) For  $a \in \mathbb{N}$  ,  $b \in \mathbb{N}$  , then  $a \times b \dots \mathbb{N}$
- (c)  $23 \times (92 + 8) = 23 \times \dots = \dots$
- (d) If  $X = \{x : x \in \mathbb{N} , 1 \leq x < 5\}$  , then  $X = \{ \dots , \dots , \dots , \dots \}$

**2 (a) Circle the true answers :**

- (1) The area of a triangle whose base length 5 cm. and the corresponding height 6 cm. is .....  $\text{cm}^2$  ( 30 or 15 or 25 or 36 )
- (2) If the set of even numbers is E , then  $E \dots \mathbb{N}$   
(  $\in$  or  $\notin$  or  $\subset$  or  $\not\subset$  )
- (3) If the longest chord in a circle is 7 cm. , then the circumference of the circle is ..... cm. where  $\pi = \frac{22}{7}$  ( 3.5 or 7 or 22 or 44 )
- (b) Draw the rectangle ABCD where  $AB = 2 \text{ cm.}$  ,  $BC = 3 \text{ cm.}$  and find its image by reflection across  $\overleftrightarrow{CD}$

**3 (a) ABCD is a rhombus in which  $AC = 10 \text{ cm.}$  and  $BD = 8 \text{ cm.}$**

- (1) Find its area.
- (2) Find the image of  $\Delta ABC$  by reflection across  $\overleftrightarrow{AC}$  .
- (b) Hatem bought 3 notebooks , where the price of each is L.E.  $x$ . He gave the seller L.E. 20 and he still has L.E. 5. Write an equation to represent this information and find  $x$ .

**4 (a) In 2-dimensional coordinate plane locate the points A (3 , 0) , B (5 , 0) , C (0 , 5) and D (0 , 3). Find the area of the shape ABCD.**

- (b) Use the commutative and associative properties in  $\mathbb{N}$  to calculate :  
 $872 + 199 + 128 + 801$





## Final Examinations

- 5 (a) In the opposite figure : There is a window which has the form of a square whose side length is 70 cm. , and above it , there is a semicircle. **Calculate.**

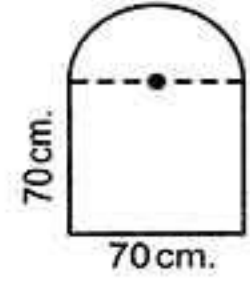

- (1) The perimeter of the window.  
 (2) If the area of the window is  $6825 \text{ cm}^2$  , then find the area of the semicircle.

- (b) The following is a frequency distribution for the working hours of 50 workers. Graph these data using the frequency polygon.

Sets	2 –	4 –	6 –	8 –	10 –	Total
Frequency	8	9	15	16	2	50

## Model 3



Answer the following questions :

- 1 Circle the true answer :

- (a) If  $x + 7 = 19$  ,  $x \in \mathbb{N}$  , then  $x = \dots\dots\dots$  ( 26 or 12 or 11 or 13 )  
 (b) The area of a square whose diagonal length 6 cm. is  $\dots\dots\dots$   
 ( 18  $\text{cm}^2$  or 36  $\text{cm}^2$  or 12  $\text{cm}^2$  or 6  $\text{cm}^2$  )  
 (c) If :  $X = \{x : x \in \mathbb{N} , 3 < X < 4\}$  , then  $x \in \dots\dots\dots$   
 (  $\emptyset$  or  $\{3, 4\}$  or  $\{3\}$  or  $\{4\}$  )

- 2 (a) Complete to get a true sentence :

- (1) The circumference of a circle whose diameter length  $x$  cm. is  $\dots\dots\dots$  cm.  
 (2) If the area of a rhombus is  $16 \text{ cm}^2$  and the length of one diagonal is 4 cm. , then the length of the other diagonal is  $\dots\dots\dots$  cm.

- (b) Which is greater in area : A rhombus whose diagonals are 6 cm. and 8 cm. , or a square whose diagonal is 8 cm.

- (c) Solve  $2x + 9 = 21$  ,  $x \in \mathbb{N}$

- 3 (a) In a 2 – dimensional coordinate plane , locate the points A (5 , 0) , B (9 , 0) , C (9 , 4) and D (5 , 4). Name the shape ABCD and find its area.

- (b) Use operations properties in  $\mathbb{N}$  to calculate :  $25 \times 9892 \times 4$

- 4 The opposite figure shows a football playground. Find the distance around the figure when  $\pi = \frac{22}{7}$

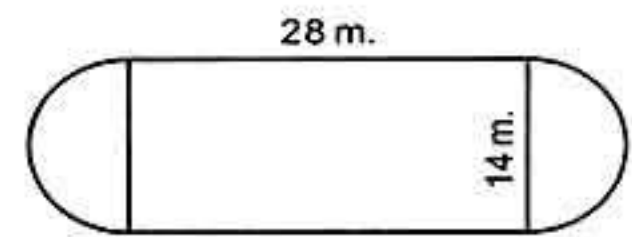

139



## Final Examinations

- 5 The following table shows the number of students who practice sports.

Represent these data using pie graph on the opposite figure :

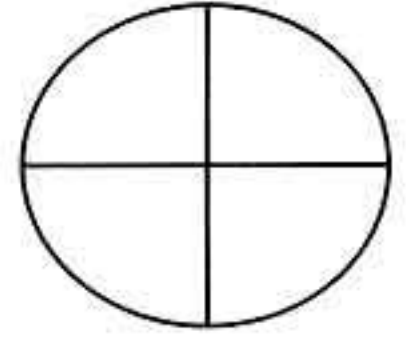

Game	Football	Basketball	Volleyball
Number	20	10	10

## Model 4



Answer the following questions :

- 1 Circle the true answers :

- (a)  $6 + 15 \div 3 \times 5 - 30 = \dots\dots\dots$  ( 5 or 25 or 1 or 10 )  
 (b) If  $3x = 15$ ,  $x \in \mathbb{N}$ , then  $x = \dots\dots\dots$  ( 5 or 12 or  $\frac{1}{5}$  or  $\frac{1}{3}$  )  
 (c) The area of a rhombus whose diagonals 10 cm. and 20 cm. is  $\dots\dots\dots$   $\text{cm}^2$  ( 200 or 30 or 100 or 400 )

- 2 Complete to get a true sentence :

- (a) The circumference of a circle whose radius length  $r = \pi \times \dots\dots\dots$   
 (b) If A ( 2 , 3 ) and B ( 2 , 7 ) , then C (  $\dots\dots\dots$  ,  $\dots\dots\dots$  ) is the midpoint of  $\overline{AB}$  .  
 (c) The length of the diagonal of a square with area  $50 \text{ cm}^2 = \dots\dots\dots$   
 (d) The area of a parallelogram whose base length is 8 cm. and height 2.5 cm. is  $\dots\dots\dots \text{cm}^2$

- 3 (a) In the opposite figure :

The length of the diameter  $\overline{AB}$  of a semicircle is 14 cm.  
 Find the distance around the figure ( $\pi = \frac{22}{7}$ )

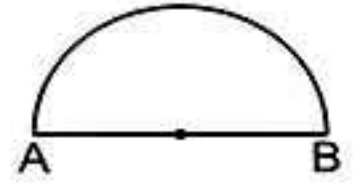

- (b) Use operations properties to calculate :  $653 + 548 + 347$

- 4 (a) If  $X = \{x : x \in \mathbb{N}, 3 \leq x < 8\}$ . Use the listing method to write X then represent its elements on a number line.

- (b)  $\triangle ABC$  is a right-angled triangle at B ,  $AB = 6 \text{ cm}$  ,  $BC = 8 \text{ cm}$ . and  $AC = 10 \text{ cm}$ . Find the area of the triangle , then draw  $\overline{BD} \perp \overline{AC}$  and find the length of BD.

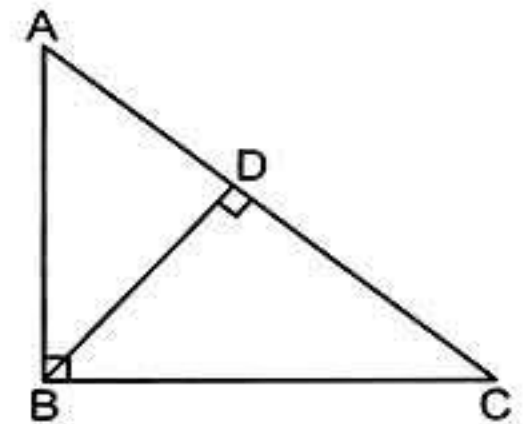





## Final Examinations

- (c) Three times of a natural number  $x$  is 8 more than the multiplicative neutral. Express this information in an equation and solve it for  $x$ .

- 5 (a) Draw  $\triangle ABC$  where A (2 , 5) and B (5 , 2) and C (5 , 8) , then find its image by reflection across  $\overrightarrow{BC}$ .

- (b) A farm has an area of 24 feddans planted with fruit , vegetables , flowers and plam trees and it is represented by the opposie figure.

**Complete :**

- (1) The area planted with vegetables is 12 feddans and it is represented by the ..... colour.  
 (2) The green sector represents the area planted with fruit and it has an area of ..... feddans.  
 (3) The area planted with flowers = the area planted with palm trees = ..... feddans.

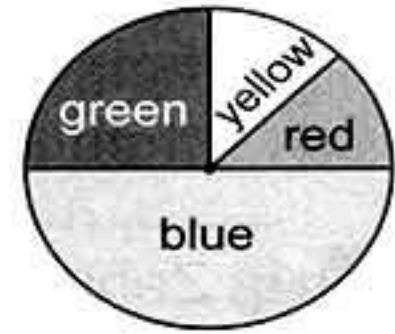

## Model 5



Answer the following questions :

- 1 Complete the following :

- (a) The set of even numbers (E) – The set of odd numbers (O) = .....  
 (b) The multiplicative neutral element in  $\mathbb{N}$  is .....  
 (c) Shorouk saved  $x$  pounds , her father gave her 10 pounds , then she has ..... pounds  
 (d) The sum of two numbers is 21 one the them is  $x$  , than the other = .....  
 (e) The side length of a square is 10 cm. , then its area = .....

- 2 Choose the correct answer from these between brackets :

- (a) The set of even numbers ..... the set of natural numbers.  
 ( $\in$  or  $\notin$  or  $\subset$  or  $\not\subset$ )  
 (b) If  $x$  is an odd number , then  $x + 3$  is ..... number.  
 (odd or even or prime)  
 (c) Twice the number  $x$  subtracted 3 from it = .....  
 ( $x - 3$  or  $2x + 3$  or  $2x - 3$  or  $3 - 2x$ )



## Final Examinations

- (d) The base length of a triangle is 8 cm. and its height is 5 cm. , then its surface area = ..... ( 40 cm. or 40 cm<sup>2</sup> or 20 cm<sup>2</sup> )
- (e) The number of axes of symmetry of the rhombus equals ..... ( zero or 1 or 2 or 4 )

**3** (a) Five even natural numbers , the greatest number is  $x + 13$  , write down these numbers.

- (b) Which is greater in area : A rhombus in which the lengths of its diagonals are 8 cm. and 6 cm. or the parallelogram in which the length of its base is 10 cm. and the corresponding height is 5 cm. , then calculate the difference between them.

**4** (a) Zahraa saved 14 pounds , she bought 3 notebooks of  $x$  pound for each. The remainder with her was 8 pounds. Express these situations by an equation.

- (b) Calculate the perimeter of the opposite figure where  $AM = 35$  cm. ( $\pi = \frac{22}{7}$ )

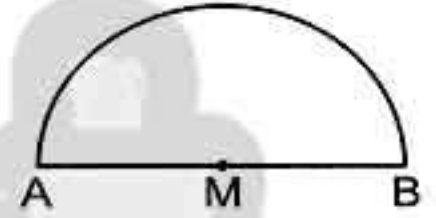

**5** (a) In the cartesian coordinates plane determine the points. A (2 , 2) , B (5 , 2) , C (5 , 8) and D (2 , 8). If  $\overline{BC}$  is the axis of reflection of the figure ABCD , then determine the image of the figure ABCD.

- (b) The following table shows the marks of 50 pupils in exam of mathematics in one of months where the full mark is 50 marks. Draw the frequency histogram and the frequency polygon which represent these date.

Sets	10 –	20 –	30 –	40 –	Total
Frequency	10	12	18	10	50

## Model 6



Answer the following questions :

**1** Choose the correct answer from those given :

- (a)  $(3 + 9) \dots \mathbb{N}$  (  $\subset$  or  $\in$  or  $\not\subset$  or  $\notin$  )
- (b) If :  $x(75 + 10) = 9 \times 85$  , then  $x = \dots$  ( 5 or 85 or 9 or 8 )







## Final Examinations

## Model 7



Answer the following questions :

**1** Choose the correct answer from those given :

- (a) If  $x + 8 = 15$ ,  $x \in \mathbb{N}$ , then  $x = \dots\dots\dots$  (3 or 7 or 6 or 5)
- (b) The square whose diagonal length is 8 cm. its area =  $\dots\dots\dots$  cm<sup>2</sup>  
(64 or 32 or 16 or 8)
- (c) If  $X = \{x : x \in \mathbb{N}, 3 \leq x < 5\}$ , then  $x \in \dots\dots\dots$   
( $\{4\}$  or  $\{3\}$  or  $\{3, 4\}$  or  $\{4, 5\}$ )
- (d) If O is the set of odd number, then  $O \dots\dots\dots \mathbb{N}$   
( $\subset$  or  $\in$  or  $\not\subset$  or  $\notin$ )
- (e) The triangle whose base length is 5 cm., and the corresponding height of it is 6 cm., its area =  $\dots\dots\dots$  cm<sup>2</sup>  
(30 or 15 or 25 or 36)

**2** Complete the following :

- (a)  $64 + (36 + \dots\dots\dots) = (64 + \dots\dots\dots) + 35 = \dots\dots\dots + 35 = \dots\dots\dots$
- (b) The rhombus whose area is 36 cm<sup>2</sup> and the length of one of its diagonals is 8 cm., the length of the other diagonal =  $\dots\dots\dots$  cm.
- (c) The square whose area is 72 cm<sup>2</sup>, the length of its diagonal =  $\dots\dots\dots$  cm.
- (d) 1, 4, 8, 13,  $\dots\dots\dots$  in the same pattern.
- (e) If:  $4 + x = 15$ , then  $x = \dots\dots\dots$

- 3** (a) The length of the diameter of the wheel of a bicycle is 56 cm. Calculate the covered distance if the wheel turns one turn and what the number of turns to cover distance 352 metres (where  $\pi = \frac{22}{7}$ )
- (b) If the number  $x$  exceeds twice the number ( $y$ ) by 7. Write down the mathematical relation which relates  $x$  by  $y$ .
- (c) If the age of a man now is  $x$  years where  $x \in \mathbb{N}$  Find :  
(1) The age of the man after 7 years.  
(2) The age of the man since 10 years.

**4** (a) Using the properties of commutation, distribution and association Find the value of each of the following :

(1)  $8 \times 137 \times 125$

(2)  $28 + 59 + 72$





(b) In the opposite figure :

ABCD is a rectangle of area  $828 \text{ cm}^2$

$E \in \overline{BC}$  ,  $AD = 23$  ,  $BE = 35 \text{ cm}$ .

Find the area of  $\Delta DCE$

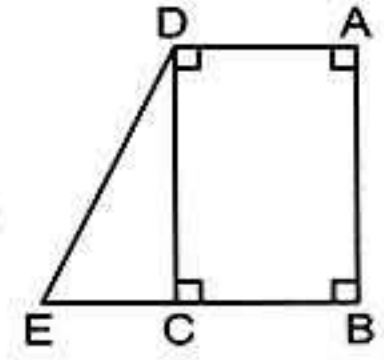

5 (a) The following table shows the marks of 40 pupils in mathematics exam.

(1) Find the value of A

(2) Draw the frequency histogram and the frequency polygon which represent these data.

Sets	10 –	20 –	30 –	40 –	50 –	Total
Frequency	5	7	12	A	7	40

(b) In the orthogonal cartesian coordinates locate the points. A (8 , 2) , B (3 , 2) , C (3 , 6) , D (8 , 6) , then complete :

(1) The length of  $\overline{AB}$  = ..... unit.

(2) The length of  $\overline{BC}$  = ..... unit.

(3) The figure ABCD is .....

(4) The perimeter of the figure ABCD = ..... unit.

### Model 8



Answer the following questions :

1 Choose the correct answer from those between brackets :

- (a) A parallelogram in which , the lengths of two adjacent sides are 5 cm. and 7 cm. , the length of the smaller height = 4 cm. , then its area = .....  $\text{cm}^2$  ( 20 or 10 or 28 or 14 )
- (b) 7 is subtracted from the number  $x = \dots\dots\dots$  (  $7 - x$  or  $2x - 7$  or  $7x + 2$  or  $14x$  )
- (c) If :  $X = \{x : x \in \mathbb{N} , x < 3\}$  , then  $x \in \dots\dots\dots$  (  $\{1, 2\}$  or  $\{0, 1\}$  or  $\{2\}$  or  $\{0, 1, 2\}$  )
- (d) The next number in the pattern 1 , 3 , 9 , 27 , ..... ( 30 or 33 or 36 or 81 )
- (e) The length of the base of the triangle whose area is  $120 \text{ cm}^2$  and its height is 5 cm. = ..... cm. ( 12 or 48 or 24 or 6 )



## Final Examinations

**2 Complete the following :**

- (a) If :  $3x + 7 = 19$  ,  $x \in \mathbb{N}$  , then  $x = \dots\dots\dots$
- (b) The circle whose diameter length is 14 cm. , its circumference =  $\dots\dots\dots$  cm.  
(where  $\pi = \frac{22}{7}$ )
- (c) The set of prime numbers which are less than 17 is  $\dots\dots\dots$
- (d) The perimeter of a rectangle is 16 cm. its width is 3 cm. , then its area =  $\dots\dots\dots$  cm<sup>2</sup>
- (e)  $74 \times (73 + 27) = 74 \times \dots\dots\dots = \dots\dots\dots$

**3 (a) Use the distribution property to find the value of :**

- (1)  $519 \times 99$  (2)  $316 \times 1001$

- (b) In the opposite figure : ABCD is a parallelogram in which  $BC = 14$  cm. and the area of the parallelogram =  $112$  cm<sup>2</sup> M is the midpoint of  $\overline{AD}$

**Complete :**

- (1)  $DN = \dots\dots\dots$  cm.  
(2) The area of  $\triangle BAM = \dots\dots\dots$  cm<sup>2</sup>  
(3) The area of the figure MBCD =  $\dots\dots\dots$  cm<sup>2</sup>

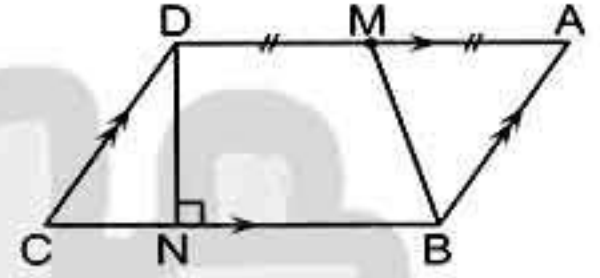
**4 In the cartesian coordinates plane :**

- (a) locate the points : A (5 , 9) , B (9 , 7) , C (5 , 5) , D (1 , 7) , E (9 , 5)
- (b) Draw the line segments  $\overline{AB}$  ,  $\overline{AD}$  ,  $\overline{CD}$  ,  $\overline{BC}$
- (c) If  $\overline{CE}$  is the axis of reflection of the figure ABCD , then determine its image and determine each of the ordered pairs which represent the vertices of the image.
- (d) The figure ABCD is a  $\dots\dots\dots$  and the area of the figure ABCD =  $\dots\dots\dots$  square units.

**5 (a) Solve each of the following equations :**

- (1)  $482 = x + (8 \times 10) + (4 \times 100)$  (2)  $x \times 3 + x \times 60 = 4 \times 63$

- (b) An employee spends his monthly salary as follow 1000 pounds for food. 500 pounds for clothes 250 pounds the rent of the flat , 250 pounds other spending. Represent these data on the shown circular sectors.

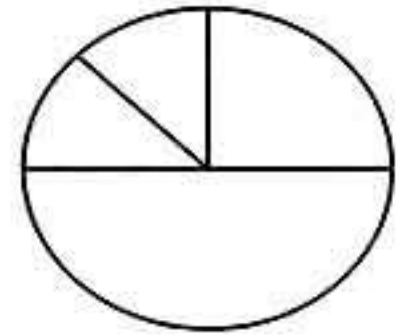
**Model 9**

Answer the following questions :

**1 Choose the correct answer from those given :**

- (a) If  $X = \{x : x \in \mathbb{N} , 2 \leq x \leq 3\}$  , then  $x = \dots\dots\dots$   
( {3 , 2} or {3} or {2} or  $\emptyset$  )





## Final Examinations

- (b)  $(49 \div 8) \dots\dots N$  ( $\in$  or  $\notin$  or  $\subset$  or  $\not\subset$ )
- (c) A rhombus of area  $30 \text{ cm}^2$ , the length of one of its diagonals is 6 cm. , then the length of the other diagonal =  $\dots\dots$  cm.  
(4 or 6 or 8 or 10)
- (d) The diameter length of circle whose circumference = 88 equals  $\dots\dots$  cm.  
( $\pi = \frac{22}{7}$ ) (28 or 14 or 7 or 21)
- (e) The length of the base of the triangle is 8 cm. and its height is 5 cm. , then its area =  $\dots\dots$   $\text{cm}^2$  (9 or 40 or 8 or 20)

## 2 Complete the following :

- (a) The set of the natural numbers which are more than 4 and less than 5 is  $\dots\dots$
- (b) If we add 5 to three times of the number  $y$ , then we get the number  $\dots\dots$
- (c) The perimeter of a rectangle is 16 cm. , its width is  $x$  cm. , then its length =  $\dots\dots$  cm.
- (d) The square whose area is  $18 \text{ cm}^2$ , the length of its diagonal =  $\dots\dots$
- (e) If  $945 = (x \times 100) + 45$ , then  $x = \dots\dots$

## 3 (a) Solve each of the following equations :

(1)  $\frac{1}{3}x + 8 = 10$  (2)  $\frac{1}{6}x - 3 = 2$

- (b) The area of a rectangle equals the area of a square whose diagonal length is 12 cm. Find the perimeter of the rectangle if its width equals 8 cm.

4 (a) If the length of the diameter of the wheel of a bicycle is 50 cm. How long is the distance covered by the bicycle in metre. If it turns 1200 turns. (where  $\pi = 3.14$ )

- (b) In the orthogonal cartesian coordinates.
- (1) Locate the points A (8 , 5) , B (8 , 2) , C (5 , 7) , D (5 , 2)
- (2) If  $\overline{CD}$  is the axis of reflection of the figure ABDC , determine the image of the figure using the suitable symbols also determine each of the ordered pairs which represent the images of the vertices.

## 5 The following table shows the frequency distribution of the number of work hours of 50 workers.

Sets	4 -	6 -	8 -	10 -	Total
Frequency	12	8	16	14	50

Draw the frequency polygon which represent these data.



## Final Examinations

## Model Examinations

## Model 1



Answer the following questions :

**1 Choose the correct answer :**

- (a) Number of axes of symmetry of square = ..... (1 or 2 or 3 or 4 )  
 (b) If :  $X = \{x : x \in \mathbb{N}, 3 \leq x < 5\}$  , then  $x = \dots\dots\dots$   
 ( {4} or {3} or {3,4} or {4,5} )  
 (c)  $x$  and  $y$  are two numbers where their sum is 20 , then  $y = \dots\dots\dots$   
 (  $20 + x$  or  $20 - x$  or  $x - 20$  or  $\frac{x}{20}$  )  
 (d) If :  $O$  is the set of odd numbers , then  $O \dots\dots\dots \mathbb{N}$   
 (  $\in$  or  $\notin$  or  $\subset$  or  $\not\subset$  )

**2 Complete the following :**

- (a) The length of the diagonal of square is 8 cm. , then its area = ..... cm<sup>2</sup>  
 (b) If :  $16 - x = 9$  , then  $x = \dots\dots\dots$   
 (c) The type of the opposite transformation is a .....   
 (d) 1 , 1 , 2 , 3 , 5 , 8 , ..... , ..... (in the same pattern)

**3 (a) In the opposite figure :**

ABC is a right-angled triangle at A , AB = 6 cm. , AC = 8 cm. , BC = 10 cm. ,  $\overline{AD} \perp \overline{BC}$  find the length of  $\overline{AD}$

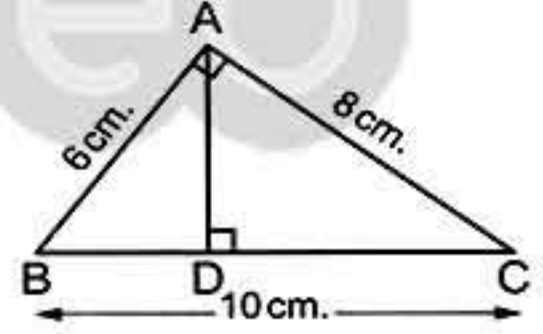

**(b) Use the properties of addition in  $\mathbb{N}$  to find the result of :**

$873 + 199 + 127 + 801$  (write the used property)

**4 (a) Solve the equation :**

$2x + 3 = 5$  where  $x \in \mathbb{N}$

**(b) Calculate the perimeter**

of the opposite figure where  $AM = 35$  cm. ( $\pi = \frac{22}{7}$ )

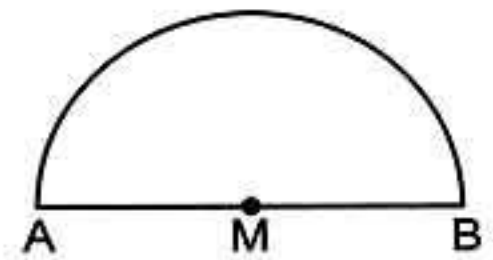





## Final Examinations

- 5 (a) On coordinate plane draw the triangle ABC where A (2 , 1) , B (5 , 1) and C (5 , 5) , then draw the image of  $\Delta ABC$  by reflection in  $\overline{BC}$
- (b) Draw the frequency polygon which represent these data.

Sets	4 -	6 -	8 -	10 -	Total
Frequency	8	12	9	6	35

## Model 2



Answer the following questions :

- 1 Choose the correct answer :

- (a)  $(5 - 7) \dots\dots \mathbb{N}$  (  $\subset$  or  $\in$  or  $\not\subset$  or  $\notin$  )
- (b) The type of the opposite transformation is a  $\dots\dots$   
( translation or reflection or rotation )
- (c) If :  $x - 3 = 5$  ,  $x \in \mathbb{N}$  , then  $x = \dots\dots$  ( 8 or 2 or 6 or 7 )
- (d) The set of even numbers (E)  $\cap$  the set of prime numbers (P)  $\dots\dots$   
( P or O or  $\mathbb{N}$  or {2} )

- 2 Complete the following :

- (a) The multiplicative neutral element in the natural numbers plus 99 =  $\dots\dots$
- (b) The length of a rectangle exceeds the width by 5 , If the width of the rectangle =  $x$  cm. , then the length of the rectangle =  $\dots\dots$
- (c) The number of axes of symmetry of the rhombus =  $\dots\dots$
- (d) The rhombus whose area  $24 \text{ cm}^2$  and the length of one of its diagonals is 8 cm. the length of the other diagonal =  $\dots\dots$  cm.

- 3 (a) Which is greater in area a triangle whose base length is 10 cm. and height = 7 cm. or a parallelogram. in which the length of the base = 8 cm. and its corresponding height = 4 cm.

- (b) Using the properties of commutation and association , find the value of each of the following :

(1)  $8 \times 149 \times 125$

(2)  $28 + 78 + 72$

- 4 (a) If the age of a man now is  $x$  years where  $x \in \mathbb{N}$  Find :

(1) The age of the man after 3 years.

(2) The age of the man since 5 years.



## Final Examinations

- (b) A circle of circumference 66 cm.  
Find the length of its diameter. ( $\pi = \frac{22}{7}$ )

## 5 (a) In the coordinate plane :

Draw the figure ABCD in which A (2 , 3) , B (2 , 5) , C (5 , 5) and D (5 , 2) , then draw its image by reflection in  $\overline{CD}$

- (b) The following table shows the frequency distribution of the number of work hours of 50 workers.

Sets	4 –	6 –	8 –	10 –	Total
Frequency	12	8	16	14	50

Draw the frequency histogram and frequency polygon which represent these data.

## Model 3



Answer the following questions :

## 1 Choose the correct answer :

- (a) The number of axes of symmetry of the parallelogram = .....  
( 0 or 1 or 2 or 4 )
- (b) The area of a square is  $72 \text{ cm}^2$  , then the length of its diagonal is .....  
( 8 or 7 or 9 or 12 )
- (c) The difference between two numbers is 7 the smaller is  $y$  , then the greater number = .....  
(  $7y$  or  $7-y$  or  $y-7$  or  $7+y$  )
- (d) The least prime number  $\times$  any prime number = ..... number  
( odd or even or prime )

## 2 Complete the following :

- (a) The additive neutral element in  $(\mathbb{N})$  is ..... , while the multiplicative neutral element in  $\mathbb{N}$  is .....
- (b) If :  $86 \times 15 = 86 \times x + 86 \times 10$  , then  $x =$  .....
- (c) If we add 7 to three times the number  $y$  then we shall get the number .....
- (d) If A (2 , 3) and B (2 , 7) , then C ( ..... , ..... ) is the midpoint of  $\overline{AB}$

## 3 (a) Use the distributive property to get the product in each of the following :

(1)  $98 \times 37$

(2)  $299 \times 17$

- (b) Solve each of the following equations :

(1)  $3x + 8 = 29$

(2)  $\frac{1}{7}x - 3 = 1$

150



هذا العمل خاص بموقع ذاكرولى التعليمى ولا يسمح بتداوله على مواقع اخرى





## Final Examinations

- 4 (a) The length of the diagonals of a rhombus are 12 cm. and 16 cm. and its height is 9.6 cm. find its side length.

- (b) In the opposite figure complete :

- (1)  $\triangle BEF$  is the image of  $\triangle AEF$   
by reflection in  $\longleftrightarrow$  .....
- (2)  $\triangle BDF$  is the image of  $\triangle CDF$   
by reflection in  $\longleftrightarrow$  .....

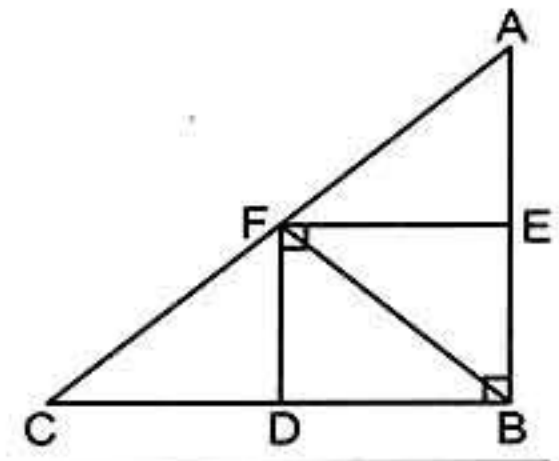

- 5 (a) If the length of the diameter of the wheel of a bicycle is 50 cm. How long is the distance covered by the bicycle in metre. If it turns 1 000 turns ( $\pi = 3.14$ )

- (b) Represent the following data by the frequency polygon :

Sets	5 -	10 -	15 -	20 -	25 -
Frequency	6	12	19	12	4

## Model 4



Answer the following questions :

- 1 Choose the correct answer :

- (a) If :  $x$  is an odd number , then  $x + 2$  is ..... number.  
( an even or an odd or a prime )
- (b) The side length of a rhombus is  $x$  and its perimeter is  $P$  , then the mathematical relation between  $P$  and  $x$  is :  $P =$  .....  
(  $4x$  or  $x+4$  or  $x-4$  or  $x \div 4$  )
- (c) The number of axes of symmetry of equilateral triangle = .....  
( 0 or 1 or 2 or 3 )
- (d) 1 , 4 , 9 , 16 , ..... (in the same pattern) ( 23 or 24 or 25 or 30 )

- 2 Complete the following :

- (a) If :  $X = \{x : x \in \mathbb{N}, 1 \leq x < 6\}$  , then  $X =$  .....
- (b) The type of the opposite transformation is a .....
- (c) The area of a triangle whose base length 5 cm. and the corresponding height 6 cm. is .....  $\text{cm}^2$
- (d) The perimeter of a rectangle is 10 cm. and its width =  $x$  cm. , then its length = ..... cm.

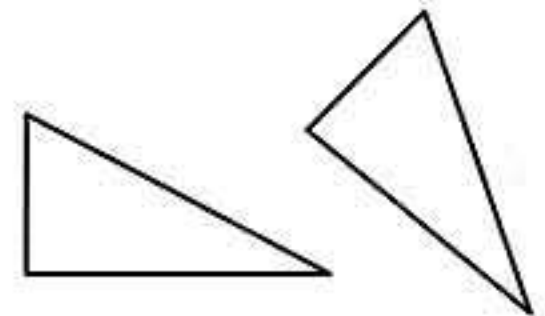



## Final Examinations

## 3 (a) In a 2-dimensional coordinate plane :

Draw the triangle ABC where A (2 , 1) , B (5 , 1) and C (5 , 5) , then draw the image of the  $\Delta ABC$  by reflection in  $\overleftrightarrow{BC}$  and find the sum of areas of the triangle and its image.

## (b) By using the properties calculate the value of :

(1)  $123 + 254 + 377 + 246$

(2)  $25 \times 125 \times 4$

## 4 (a) In the opposite figure :

ABCD is a parallelogram where AD = 12 cm. , CD = 6 cm. , DE = 5 cm. and  $\overline{DE} \perp \overline{BC}$

Find the area of the parallelogram , then calculate its height drawn from the point D on  $\overleftrightarrow{AB}$

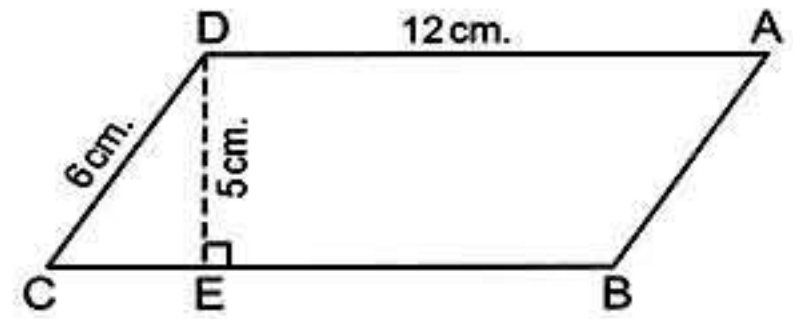

## (b) Solve each of the following equations :

(1)  $\frac{1}{3}x + 8 = 10$

(2)  $\frac{1}{6}x - 3 = 4$

## 5 (a) An employee spends his monthly salary as follow 1000 pounds for food 500 pounds for clothes 250 for the rent of the flat , 250 other spending. Represent these data on the shown circular sectors.

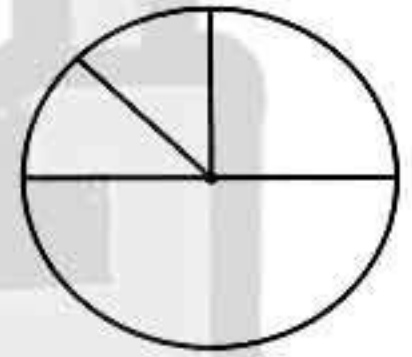
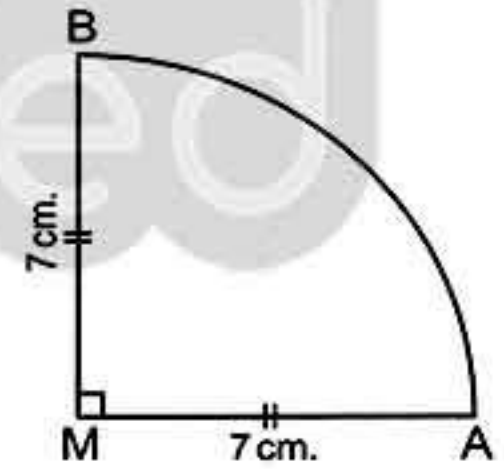
(b) Find the perimeter of the opposite figure where MA = MB = 7 cm. ( $\pi = \frac{22}{7}$ )

## Model 5



Answer the following questions :

## 1 Choose the correct answer :

(a) Double the number  $x$  subtracted 7 from it equals .....

(  $x - 7$  or  $2x - 7$  or  $7x + 2$  or  $14x$  )

(b) The number of axes of symmetry of the rectangle = .....

( 0 or 1 or 2 or 4 )





## Final Examinations

- (c) If :  $X = \{x : x \in \mathbb{N}, 5 < x < 6\}$  , then  $X = \dots\dots\dots$   
 ( $\emptyset$  or  $\{5, 6\}$  or  $\{5, 5\}$  or  $\{5\}$ )
- (d) If the longest chord in a circle is 7 cm. , then the circumference of the circle is  $\dots\dots\dots$  cm. where  $\pi = \frac{22}{7}$  ( $3.5$  or  $7$  or  $22$  or  $44$ )

## 2 Complete the following :

- (a) For  $a \in \mathbb{N}$  ,  $b \in \mathbb{N}$  , then  $a \times b \dots\dots\dots \mathbb{N}$
- (b) If : A (5 , 2) and B (5 , 6) , then the coordinates of the midpoint of  $\overline{AB}$  are (  $\dots\dots\dots$  ,  $\dots\dots\dots$  )
- (c) The least number in the set of counting numbers is  $\dots\dots\dots$
- (d) If we multiply the number L by 5 , then we subtract from the result 6 , then we shall get the number  $\dots\dots\dots$

- 3 (a) Mina bought 3 notebooks , where the price of each is L.E.  $x$  . He gave the seller L.E. 20 and he still has L.E. 5 write an equation to represent this information and find  $x$

- (b) **By using the properties of operation in  $\mathbb{N}$  find the result of :**  
 (1)  $25 \times 98 \times 4$  (2)  $642 + 173 + 358 + 27$

- 4 (a) **The area of a parallelogram =  $48 \text{ cm}^2$  and its base = 8 cm. what is its height ?**

- (b) **In the opposite figure :**  
 $\overline{AD} \perp \overline{BC}$  , E is the midpoint of  $\overline{AD}$  ,  $CB = 6 \text{ cm.}$  ,  $AD = 8 \text{ cm.}$   
 Find the area of the shaded port.

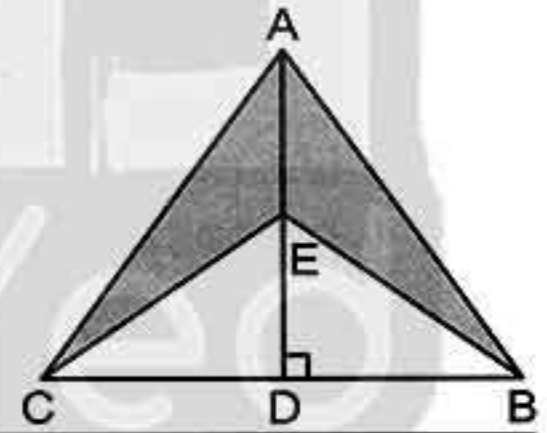

- 5 (a) In 2-dimensional coordinate plane locate the points A (3 , 0) , B (5 , 0) , C (0 , 5) and D (0 , 3) Find the area of the shape ABCD

- (b) **The following is a frequency distribution for the working hours of 50 workers. Graph these data using the frequency polygon :**

Sets	2 -	4 -	6 -	8 -	10 -	Total
Frequency	8	9	15	16	2	50

## Model 6



Answer the following questions :

- 1 Choose the correct answer :

- (a)  $(5 - 7) \dots\dots\dots \mathbb{N}$  ( $\in$  or  $\notin$  or  $\subset$  or  $\supset$ )



## Final Examinations

- (b) The number of axes of symmetry of the parallelogram = .....  
(zero or 1 or 2 or 3)
- (c) Twice the number  $x$  subtracted 3 from it = .....  
( $x - 3$  or  $2x + 3$  or  $2x - 3$  or  $3 - 2x$ )
- (d) The set of even number (E)  $\cap$  the set of prime number (P) = .....  
(P or O or  $\mathbb{N}$  or  $\{2\}$ )

## 2 Complete the following :

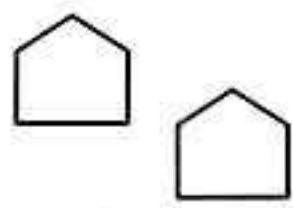
- (a) 1 , 4 , 8 , 13 , ..... , ..... in the same pattern.
- (b) Shorouk saved  $x$  pounds , her father gave her 10 pounds , then she has .....
- (c) The type of the opposite transformation is ..... 
- (d) The square whose diagonal length is 8 cm. its area = .....  $\text{cm}^2$

## 3 (a) In the opposite figure :

ABCD is a rectangle  
of area  $828 \text{ cm}^2$   
 $E \in \overline{BC}$  ,  $AD = 23 \text{ cm}$ .  
,  $BE = 35 \text{ cm}$ .  
Find the area of  $\triangle DCE$

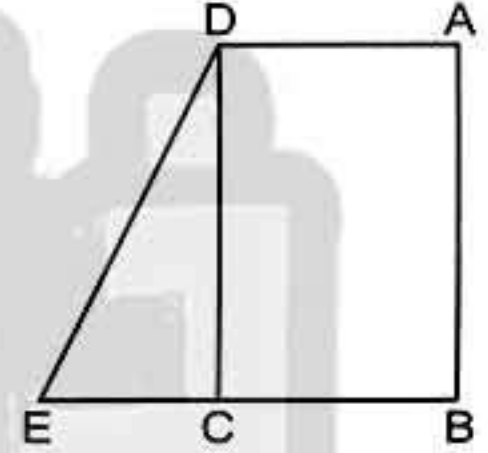

- (b) Using the properties of commutation and association find value of each of the following.

(1)  $8 \times 133 \times 125$

(2)  $27 + 69 + 73$

## 4 (a) In the opposite figure :

Calculate the perimeter of the figure ( $\pi = 3.14$ )

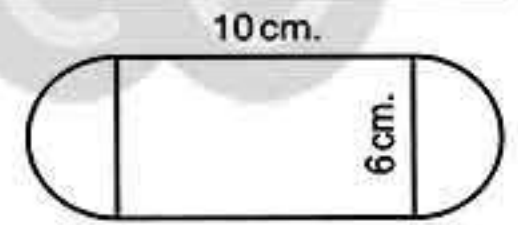

- (b) Solve each of the following equation :

(1)  $\frac{1}{3}x + 8 = 9$

(2)  $2x - 3 = 5$

- 5 (a) Graph the figure ABCD which A (4 , 8) , B (10 , 8) , C (9 , 4) , D (5 , 4) and then draw its line of symmetry.

- (b) The following table shows the frequency distribution of the number of work hours of 44 works :

Sets	4 -	6 -	8 -	10 -	Total
Frequency	10	12	6	16	44

Draw the frequency polygon which represent these data.

154





## Model 7



Answer the following questions :

**1 Choose the correct answer :**

- (a) The additive neutral element in  $\mathbb{N}$  ..... the multiplicative neutral element in  $\mathbb{N}$  ( $>$  or  $<$  or  $=$ )
- (b) The circumference of a circle with diameter length 42 cm. is ..... cm. where  $(\pi = \frac{22}{7})$  (48 or 96 or 168 or 132)
- (c) If :  $x$  is an odd number , then  $x + 2$  is ..... number. (even or odd or prime)
- (d) The sum of two natural number .....  $\mathbb{N}$  ( $\in$  or  $\notin$  or  $\subset$  or  $\not\subset$ )

**2 Complete the following :**

- (a) The set of even number (E) - the set of odd numbers (O) = .....
- (b) Number of axes of symmetry of the rhombus = .....
- (c) The opposite geometric transformation is .....
- (d) The sum of two numbers is 15 one of them is  $x$  , then the other = .....

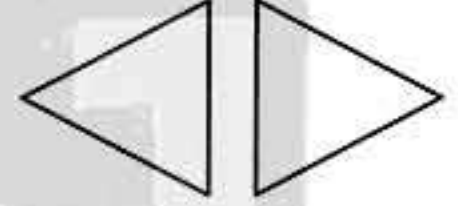

**3 (a) Write by the list method the set  $X = \{x : x \in \mathbb{N}, 3 \leq x \leq 9\}$**

, then represent its elements on the number line.

- (b) Five consecutive odd number , its middle number is  $(x + 12)$  write down these numbers.

**4 (a) Which is greater in area :**

A rhombus in which the lengths of its diagonals are 6 cm. and 8 cm. or a square in which the diagonal length = 7 cm.

**(b) In the opposite figure :**

ABCD is a rectangle of area is  $32 \text{ cm}^2$

and  $EC = 5 \text{ cm}$ .

Calculate the area of the figure AECD

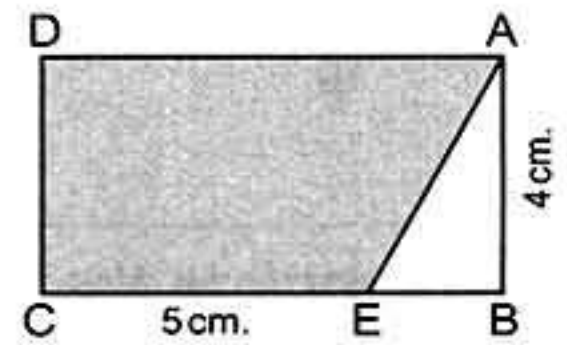



## Final Examinations

- 5 (a) A librarian made an inventory of the books in his library and their types. He found the following :  $\frac{1}{4}$  of the books are religious ,  $\frac{1}{4}$  of the books are literary ,  $\frac{1}{2}$  of the books are scientific.

Graph that given data using a pie graph. If the total of books was 800 , find the number of each type of books.

- (b) In the opposite figure : complete :

(1)  $\Delta BEF$  is the image of  $\Delta AEF$  by reflection across .....

(2)  $\Delta BDF$  is the image of  $\Delta CDF$  by reflection across .....

(3)  $\Delta ABF$  is the image of  $\Delta CBF$  by reflection across .....

(4)  $\Delta BEF$  is the image of  $\Delta BDF$  by reflection across .....

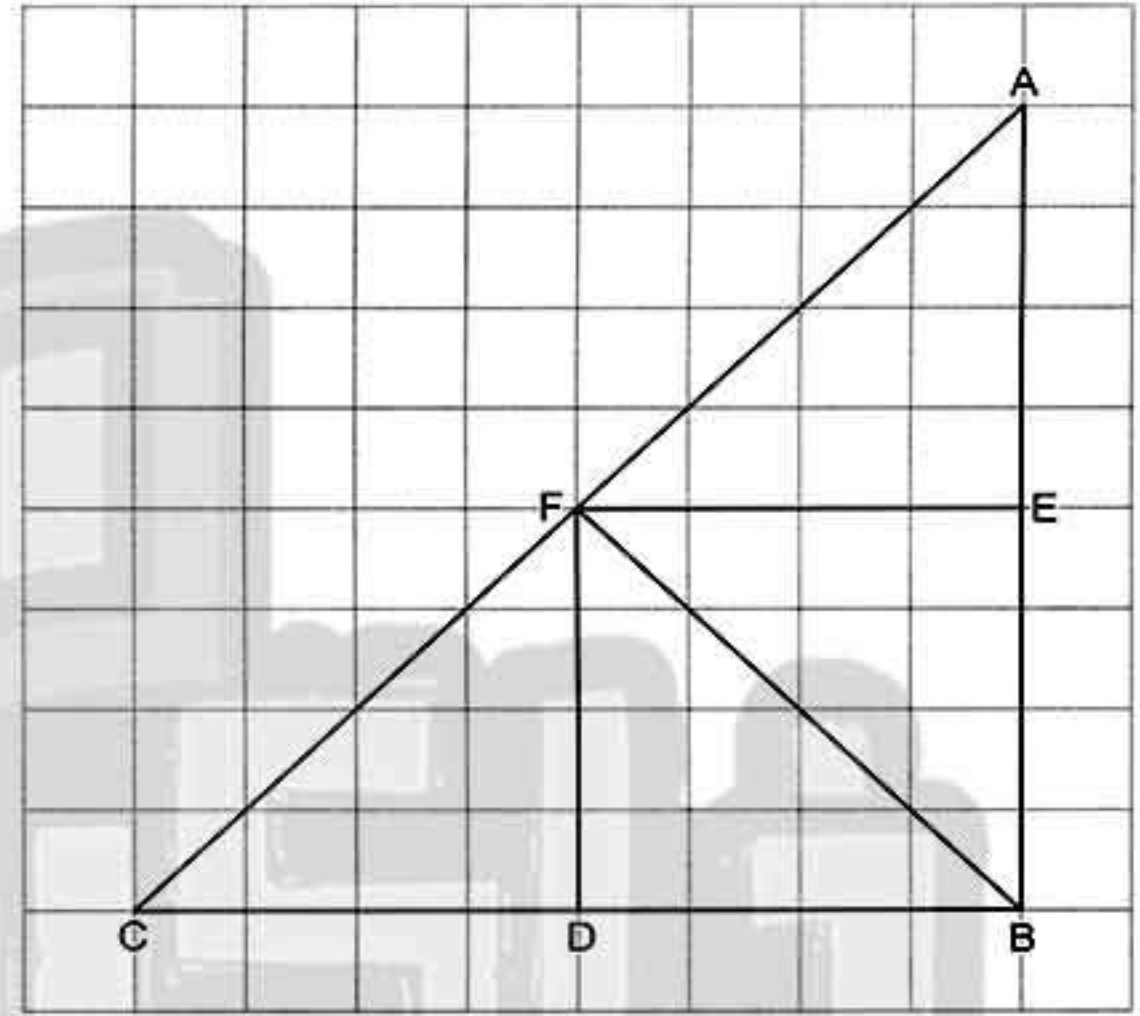

## Model 8



Answer the following questions :

- 1 Choose the correct answer :

- (a)  $\mathbb{O}$  ..... set of counting number (C) (  $\in$  or  $\notin$  or  $\subset$  or  $\supset$  )
- (b) Mina is  $x$  years old , then mina's age 3 years ago was .....  
(  $3x$  or  $3-x$  or  $x-3$  or  $x+3$  )
- (c) The number of axes of symmetry of the isosceles triangle = .....  
( zero or 1 or 2 or 3 )
- (d) The opposite egeometric transformation is .....  
( flip or slide or turn )

- 2 Complete the following :

- (a) The perimeter of the equilateral triangle whose side length is  $l$  cm. = .....

156





## Final Examinations

- (b) The set of the natural numbers which are more than 4 and less than 5 is .....
- (c) 1 , 3 , 9 , 27 , ..... (in the same pattern)
- (d) A parallelogram , in which the lengths of two adjacent sides are 5 cm. and 7 cm. , the length of the smaller height = 4 cm. , then its area = ..... cm<sup>2</sup>

## 3 (a) In the opposite figure :

ABCD is a parallelogram ,  
where AD = 12 cm.

, CD = 6 cm. , DE = 5 cm. and  $\overline{DE} \perp \overline{BC}$

Find the area of the parallelogram.

then calculate its height drawn from point D on  $\overrightarrow{AB}$

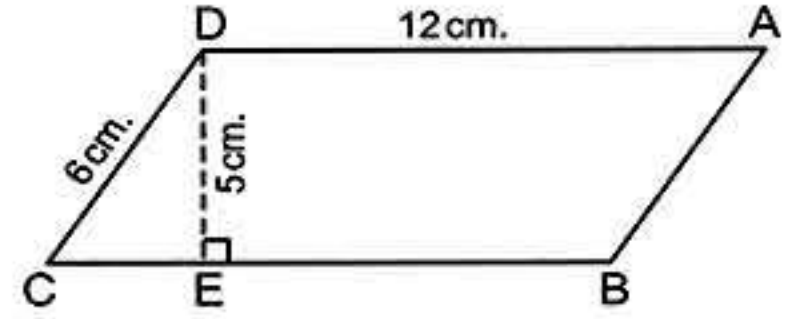

- (b) Calculate the perimeter of  
the opposite figure where

$$AM = 35 \text{ cm. } (\pi = \frac{22}{7})$$

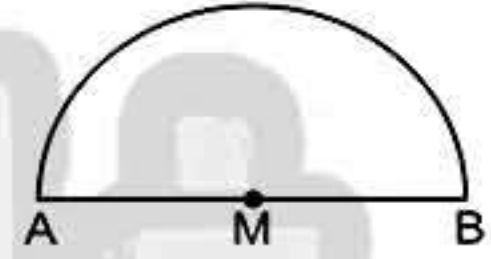
4 (a) Solve the equation :  $75 = 5x + 7 \times 10$ 

- (b) a , b , c and d are four natural numbers where  $d > a$  ,  $b < c$  ,  $c < d$  ,  $b < d$  and  $b > a$  Represent these data on a number line.

5 (a) Draw on the coordinates plane the triangle ABC where A (1 , 0) , B (2 , 2) and C (2 , 5) , then draw its image by reflection on  $\overrightarrow{BC}$ 

- (b) The following table shows the recorded temperatures in 40 cities on a day :

Temperatures	20 –	22 –	24 –	26 –	28 –	Total
Number of cities	7	9	11	8	5	40

- (1) Find the number of cities with temperatures less than 24 degrees Celsius.  
(2) Draw each of the histogram and the frequency polygon.



## Final Examinations

## Model 9



Answer the following questions :

**1 Choose the correct answer :**

- (a) The number of axes of symmetry of trapezium = .....  
( 0 or 1 or 2 or 4 )
- (b) The perimeter of rhombus is 20 cm. and its height is 6 cm. , then its area = ..... cm<sup>2</sup>  
( 30 or 120 or 24 or 26 )
- (c)  $x$  and  $y$  are two numbers where their sum is 10 then  $y =$  .....  
(  $10 + x$  or  $10 - x$  or  $x - 10$  or  $10x$  )
- (d) The multiplicative identity in  $\mathbb{N}$  is ..... ( 0 or 1 or 2 or 3 )

**2 Complete the following :**

- (a) The smallest natural number .....
- (b) If :  $2x = 10$  , then  $x =$  .....
- (c)  $0 + a = a + 0 =$  ..... (..... property)
- (d) If :  $A(3, 7)$  and  $B(5, 7)$  , then  $C( \dots, \dots )$  is the midpoint of  $\overline{AB}$

**3 (a)** Three times of a natural number  $x$  is 8 more than the multiplicative neutral. Express this information in an equation and solve it for  $x$

**(b) By using the properties of operation in  $\mathbb{N}$  find the result of the following :**

(1)  $18 \times 99$

(2)  $56 \times 1002$

(3)  $4 \times 49 \times 25$

(4)  $156 + 871 + 344 + 129$

**4 (a) In the opposite figure :**

ABC is a right-angled triangle at A  
 $AB = 6$  cm. ,  $AC = 8$  cm. ,  $BC = 10$  cm.  
 $\overline{AD} \perp \overline{BC}$  Find the length of :  $\overline{AD}$

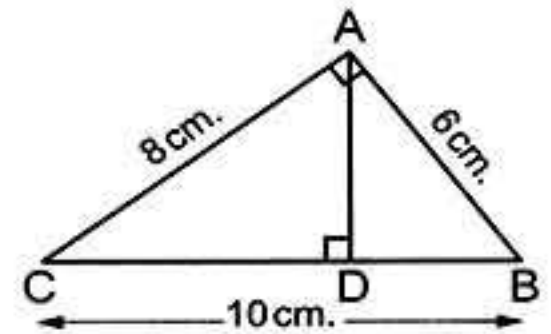

**(b) Which is greater in area ?**

A rhombus in which the lengths of its diagonals are 6 cm. and 8 cm. or a parallelogram in which its base length 4 cm. and its corresponding height 8 cm.

**5 (a)** In the cartesian coordinates plane , from the following figure. Find the image of the square by reflection on the straight line L where  $A(5, 2)$  ,  $B(7, 4)$  ,  $C(9, 2)$  ,  $D(7, 0)$





Then find :

- (1) The image of A by reflection in the straight line L.
- (2) The image of B by reflection in the straight line L.
- (3) The image of C by reflection in the straight line L.
- (4) The image of D by reflection in the straight line L.

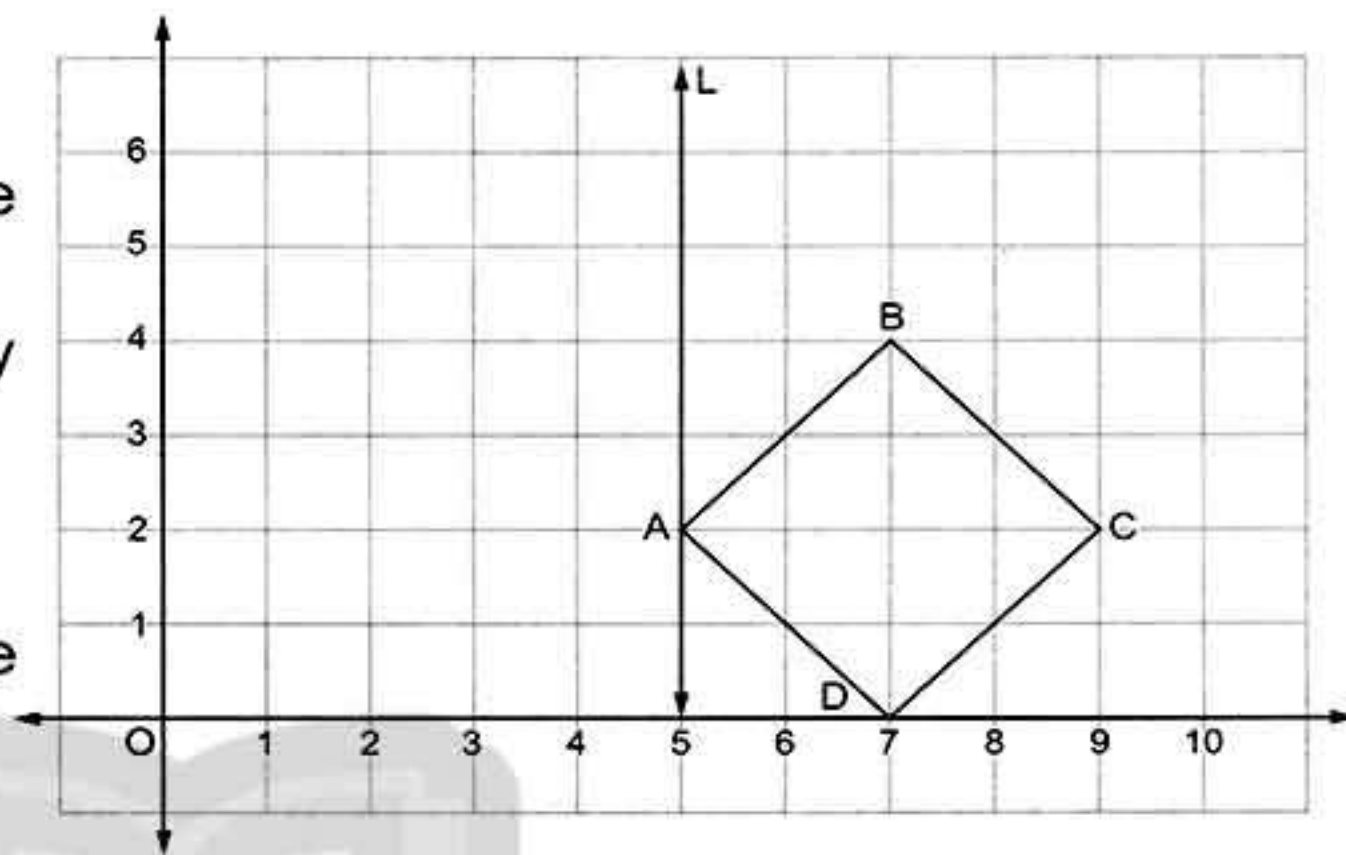

(b) Represent this data by a histogram and frequency polygon :

Sets	0 –	10 –	20 –	30 –
Frequency	40	20	30	10

### Model 10



Answer the following questions :

1 Choose the correct answer :

- (a) If O is the set of odd number , then  $O \dots \mathbb{N}$  ( $\in$  or  $\notin$  or  $\subset$  or  $\not\subset$ )
- (b) The side length of a rhombus is  $x$  and its perimeter is  $P$  the mathematical relation between  $P$  and  $x$  is :  $P = \dots$   
( $4x$  or  $x+4$  or  $x-4$  or  $x \div 4$ )
- (c) The number of axes of symmetry of an equilateral triangle = .....  
(zero or 1 or 2 or 3)
- (d) The type of the opposite transformation is .....   
(translation or reflection or rotation)

2 Complete the following :

- (a) If :  $X = \{x : x \in \mathbb{N}, 1 \leq x < 5\}$  , then  $X = \dots$
- (b) If we subtract 5 from twice the number  $Z$  , then we shall get the number .....
- (c) The circumference of a circle with diameter length 20 cm. is .....  $\pi$  cm.
- (d) If  $x$  is an even number , then  $(x + 1)$  is ..... number.



## Final Examinations

- 3 (a) The area of a piece of paper is  $312.5 \text{ cm}^2$ . If 7 congruent squares with diagonal length of each 9 cm. are cut off. Find the area of the left part of the paper.
- (b) Find the radius length of the circle if its circumference is 66 cm. ( $\pi = \frac{22}{7}$ )

- 4 (a) Use operation properties in  $\mathbb{N}$  to calculate.

(1)  $25 \times 9892 \times 4$

(2)  $862 + 199 + 138 + 801$

- (b) Solve :  $2x + 3 = 15, x \in \mathbb{N}$

- 5 (a) In a coordinate plane. Represent the points :

A (2 , 3) , B (3 , 5) and C (5 , 3) , then find the image of  $\Delta ABC$  by reflection in  $\overleftrightarrow{AC}$

- (b) The following table shows the number of students who practice sports. Represent these data using pie graph :

Game	Football	Basketball	Volleyball
Number	20	10	10

## Model 11



Answer the following questions :

- 1 Choose the correct answer :

- (a)  $\frac{2}{5-5} \dots \mathbb{N}$  ( $\in$  or  $\notin$  or  $\subset$  or  $\not\subset$ )
- (b) The smallest natural number is  $\dots$  (0 or  $\frac{1}{2}$  or  $\frac{1}{9}$  or 1)
- (c) The type of the opposite transformation is  $\dots$    
(rotation or translation or reflection)
- (d) The circumference of a circle =  $\dots$   
( $2\pi d$  or  $\pi r$  or  $4\pi r$  or  $2\pi r$ )

- 2 Complete the following :

- (a)  $20 - x = 17$  , then  $x = \dots$
- (b)  $\dots$  ,  $\dots$  , 12 , 24 , 48 (in the same pattern)
- (c) The lengths of two adjacent sides of a parallelogram are  $x$  and  $y$  , then its perimeter =  $\dots$
- (d) If : A (2 , 7) and B (2 , 3) , then the coordinates of the midpoint of  $\overline{AB}$  are (  $\dots$  ,  $\dots$  )





## Final Examinations

- 3 (a) Five even natural numbers, the greatest number is  $x + 13$ , write down these number.

- (b) *In the opposite figure :*

ABCD is a parallelogram in which

AB = 10 cm. , DE = 12 cm.

, DF = 8 cm. find : the length of  $\overline{BC}$

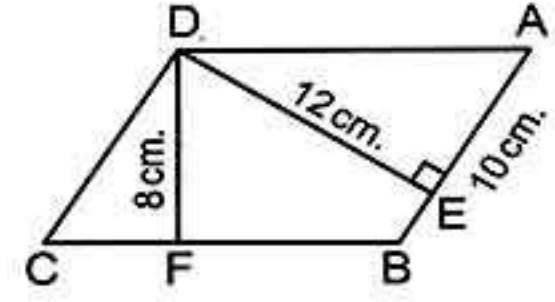

- 4 (a) *Solve the following equations :*

(1)  $3x + 5 = 26$   $x \in \mathbb{N}$

(2)  $\frac{1}{5}x - 2 = 10$   $x \in \mathbb{N}$

- (b) If the area of triangle =  $6 \text{ cm}^2$  and the length of the base = 3 cm. Find its corresponding height.

- 5 (a) *In the orthogonal cartesian coordinates locate the points A (8 , 2) , B (3 , 2) , C (3 , 6) and D (8 , 6) , then complete :*

(1) The length of  $\overline{AB}$  = ..... unit.

(2) The length of  $\overline{BC}$  = ..... unit.

(3) The figure ABCD is .....

(4) The perimeter of the figure ABCD = ..... unit.

- (b) *Using the following table of data to make the histogram :*

Sets	5 -	7 -	9 -	11 -
Frequency	4	12	9	1

## Model 12



*Answer the following questions :*

- 1 *Choose the correct answer :*

- (a) an odd number + an even number = ..... number.

( odd or even or prime )

- (b) The number of axes of symmetry of the square = .....

( 0 or 2 or 3 or 4 )

- (c) The area of a rhombus whose diagonals lengths are 4 cm. and 10 cm. is .....  $\text{cm}^2$

( 40 or 80 or 20 or 10 )

- (d) The value of  $x$  when  $x + 1 = 3$  ..... the value of  $x$  when  $2x = 6$

( > or = or < )



## Final Examinations

**2 Complete the following :**

- (a) The multiplicative identity element in  $\mathbb{N}$  is .....
- (b) The perimeter of a rectangle is 20 cm. If its length is  $x$  cm. , then its width = ..... cm.
- (c) If : A (4 , 5) and C (4 , 12) then the length of  $\overline{AC}$  = ..... length unit.
- (d)  $E \cap P = \dots\dots\dots$  where E is the set of even numbers and P is the set of prime numbers.

**3 In the opposite figure :**

There is a window which has the form of a square whose side length is 70 cm. and above it , there is a semicircle calculate.

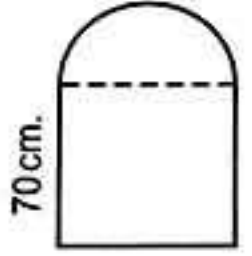

- (a) The perimeter of the window.
- (b) If the area of the window is  $6825 \text{ cm}^2$ . , then find the area of the semicircle.

**4 (a) Use the properties of addition to find the value of :  $38 + 47 + 62 + 53$** 

- (b) **Solve the following equation :  $x + 45 = 75$  (where  $x \in \mathbb{N}$ )**

**5 (a) In coordinate plane :**

Draw the triangle ABC where A (1 , 3) , B (4 , 1) , C (4 , 7) , then draw the image of triangle ABC by reflection in  $\overline{BC}$

- (b) **Represent the following distribution by frequency polygon :**

Sets	0 -	4 -	8 -	12 -	16 -
Frequency	6	10	12	5	3

**Model 13**

Answer the following questions :

**1 Choose the correct answer :**

- (a)  $\left\{ \frac{1}{2}, 1, 2 \right\} \dots\dots\dots \mathbb{N}$  ( $\in$  or  $\notin$  or  $\subset$  or  $\not\subset$ )
- (b) Double the number  $x$  subtracted 7 from it equals .....
- (  $x - 7$  or  $2x - 7$  or  $7x + 2$  or  $14x$  )
- (c) The number of axes of symmetry of parallelogram = .....
- ( 0 or 1 or 2 or 4 )
- (d)  $39 \times 115 = 39 \times 100 + 39 \times \dots\dots\dots$  ( 115 or 10 or 5 or 15 )

**2 Complete the following :**

- (a) 3 , 9 , 27 , ..... , ..... (in the same pattern)
- (b) The sum of two numbers is 35 , one of them is  $x$  , then the other is .....





## Final Examinations

(c) The area of the rhombus whose side length = 10 cm. and its height is 9.6 cm. = ..... cm<sup>2</sup>

(d) The opposite geometric transformation is .....

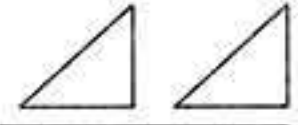

3 (a) The opposite figure is made up of an equilateral triangle of side length 7 cm. and a semicircle find its perimeter. ( $\pi = \frac{22}{7}$ )

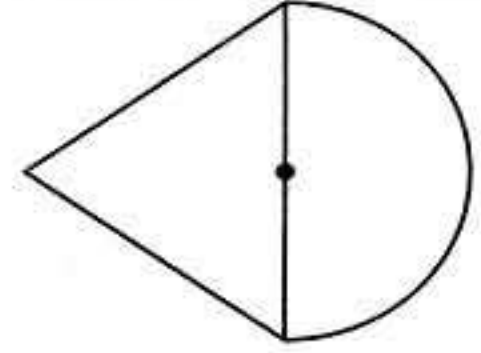

(b) A parallelogram has a base length of 8 cm. and a corresponding height of 5 cm. Find its area.

4 (a) Use the distribution property to find the value of :

(1)  $519 \times 99$

(2)  $316 \times 1001$

(b) Solve each of the following equation :

(1)  $\frac{1}{5}x - 1 = 10$

(2)  $5x + 1 = 16$

5 (a) On coordinate plane draw the rectangle ABCD where A (0 , 1) , B (3 , 1) , C (3 , 5) and D (0 , 5) , then draw its image by reflection in  $\overline{BC}$

(b) The following table shows the marks of 40 pupils in mathematics exam :

Sets	10 -	20 -	30 -	40 -	50 -	Total
Frequency	5	7	12	A	7	40

(1) Find the value of A

(2) Draw the frequency histogram and the frequency polygon which represent these data.

## Model 14



Answer the following questions :

1 Choose the correct answer :

(a)  $\mathbb{N} - \mathbb{C} = \dots\dots\dots$  ( $\{1\}$  or  $\{0\}$  or  $\mathbb{N}$  or  $\emptyset$ )

(b) The difference between two numbers is 5 , the smaller one is y , then the greater number is .....

(5y or 5 - y or y - 5 or y + 5)

(c) The number of axes of symmetry of a scalene triangle = .....

(0 or 1 or 2 or 3)

(d)  $(\frac{1}{2} + 1\frac{1}{2}) \dots\dots\dots \mathbb{N}$

( $\in$  or  $\notin$  or  $\subset$  or  $\not\subset$ )



## Final Examinations

## 2 Complete the following :

- (a) If :  $(4, a) = (2b, 6)$  , then  $a = \dots\dots\dots$  ,  $b = \dots\dots\dots$   
 (b) If :  $15 - x = 9$  , then  $x = \dots\dots\dots$   
 (c)  $\frac{\text{The circumference of the circle}}{\text{The length of its diameter}} = \dots\dots\dots$   
 (d) If :  $86 \times 15 = 86 \times x + 86 \times 10$  , then  $x = \dots\dots\dots$

3 (a) Using the properties of operations in  $\mathbb{N}$  to find the result of the following (write the used property)

(1)  $612 + 154 + 88 + 846$

(2)  $125 \times 19 \times 8$

- (b) Solve the equation :
- $2x - 4 = 8$
- where
- $x \in \mathbb{N}$

## 4 (a) In the opposite figure :

ABCD is a rectangle its area =  $32 \text{ cm}^2$ ,  $AB = BE = 4 \text{ cm}$ .

Find the area of the shaded part

- (b) Find the perimeter of the opposite figure
- 
- (
- $\pi = \frac{22}{7}$
- )

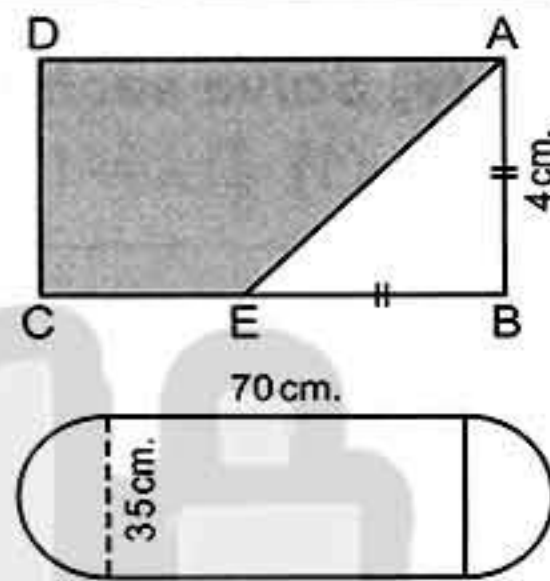

## 5 (a) In coordinate plane draw the figure ABCD in which A (4, 5), B (1, 1), C (4, 1) and D (7, 5)

(1) What is the name of the figure ABCD and calculate its area.

(2) Draw the image of the figure ABCD by reflection in  $\overleftrightarrow{CA}$ 

- (b) An employee spends his salary as follows :

L.E. 200 for clothes.

L.E. 800 for food.

L.E. 400 for transportation and medicine.

L.E. 200 for renting an apartment.

Graph that data on the opposite circle.

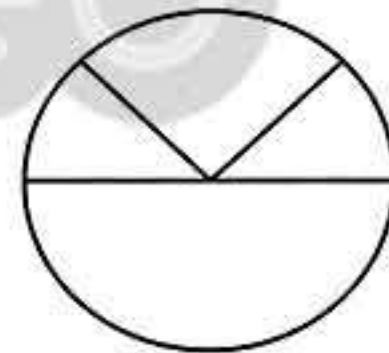

## Model 15



Answer the following questions :

## 1 Choose the correct answer :

- (a) The set of even numbers (E)  $\cup$  the set of odd numbers (O) =  $\dots\dots\dots$   
 (P or O or E or  $\mathbb{N}$ )  
 (b) If :  $6x = 66$  , then  $x = \dots\dots\dots$  ( 6 or 11 or 6.6 or 60 )





## Final Examinations

- (c) If :  $(2, 5) = (2 + x, 5)$  , then  $x = \dots\dots\dots$  ( 0 or 1 or 2 or 3 )  
 (d)  $(x - 10) \dots\dots\dots (x - 9)$  where  $x$  is a natural number more than 12  
 ( > or < or = or  $\geq$  )

## 2 Complete the following :

- (a) The additive identity in  $\mathbb{N}$  is  $\dots\dots\dots$  but the multiplicative identity is  $\dots\dots\dots$   
 (b) If we add 2 to three times the number  $y$  , then we shall get the number  $\dots\dots\dots$   
 (c) The coordinates of the midpoint of a line segment which its end points are  $(6, 8)$  and  $(4, 8)$  are  $\dots\dots\dots$   
 (d) The square whose area is  $24.5 \text{ cm}^2$  the length of its diagonal =  $\dots\dots\dots$  cm.

3 (a) Write a real life situation that can be represented by the equation  $x + 5 = 12$  , then solve for  $x$ 

- (b) Find by using the properties of addition and multiplication the result of :  $99 \times 15$

## 4 (a) Which is greater in area :

a garden of a shape of a triangle with base 8 m. and corresponding height 7 m. or a land in a shape of a rhombus of side length 5 m. and its height 10 m.

- (b) If the circumference of a circle = 88 cm. Find the length of its diameter.

5 (a) On coordinate draw  $\triangle ABC$  where  $A(0, 3)$  ,  $B(2, 0)$  ,  $C(2, 5)$  , then draw its image by reflection in  $\overline{BC}$ 

- (b) The following frequency distribution shows the marks of a group of students in an exam :

Sets	5 -	10 -	15 -	20 -	25 -	30 -	35 -	Total
Number of students	3	6	8	12	10	6	5	50

- (1) What is the number of students who got 30 marks or more.  
 (2) Draw the frequency polygon for that distribution.

## Model 16



Answer the following questions :

## 1 Choose the correct answer :

- (a)  $(x + 15) \dots\dots\dots (x + 17)$  ,  $x \in \mathbb{N}$  ( > or < or = or  $\geq$  )



## Final Examinations

- (b) Sarah saved L.E.  $x$  and her father gave her L.E. 5 she will have .....  
 (  $5x$  or  $x+5$  or  $x-5$  or  $\frac{x}{5}$  )
- (c) If : A (2 , 3) , B (2 , 5) , then the length of  $\overline{AB}$  = ..... length unit.  
 ( 3 or 5 or 2 or 1 )
- (d) If the set of even numbers is E , then E .....  $\mathbb{N}$   
 (  $\in$  or  $\notin$  or  $\subset$  or  $\not\subset$  )

## 2 Complete the following :

- (a) If :  $X = \{x : x \in \mathbb{N}, 1 \leq x < 5\}$  , then  $X = \{ \dots \}$
- (b) If :  $3x = 15$  ,  $x \in \mathbb{N}$  , then  $x = \dots$
- (c) The area of the rhombus whose side length = 10 cm. and its height is 9.6 cm. equals .....  $\text{cm}^2$
- (d) The type of the opposite geometric transformation is ..... 

## 3 (a) In the opposite figure :

ABDE is a rectangle ,  $C \in \overline{BD}$   
 Find the area of  $\triangle ABC$

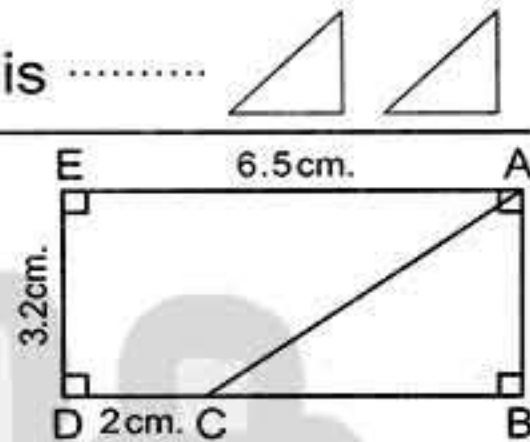

- (b) Find the area of a rhombus with diagonal length 7 cm. and 9 cm. and if its height is 5 cm. Find its side length.

4 (a) Use the properties to find the value of :  $48 + 637 + 52 + 363$ 

- (b) Solve the equation :  $\frac{1}{3}x - 1 = 3$  ,  $x \in \mathbb{N}$

5 (a) On the coordinate plane : Draw the triangle ABC where A (2 , 1) , B (5 , 1) and C (5 , 5) , then draw the image of triangle ABC by reflection in  $\overline{BC}$ .

- (b) The following table shows the recorded temperatures in 40 cities on a day :

Temperatures	20 -	22 -	24 -	26 -	28 -	Total
Number of cities	7	9	11	8	5	40

Required :

- (1) The number of cities with temperatures less than 24 degrees Celsius.  
 (2) Draw each of the histogram and the frequency polygon.

## Model 17



Answer the following questions :

## 1 Choose the correct answer :

- (a) The least prime number  $\times$  any prime number = ..... number.  
 ( odd or even or prime )





## Final Examinations

- (b) The number of axes of symmetry of the parallelogram = .....  
(zero or 1 or 2 or 4)
- (c) Subtracting 3 from double of the number  $x$  = .....  
( $x - 3$  or  $2x - 3$  or  $3x + 2$  or  $5x$ )
- (d)  $(4 \times \dots) \times 78 = 7800$  (5 or 25 or 50 or 125)

## 2 Complete the following :

- (a) If :  $945 = (x \times 100) + 45$  , then  $x = \dots$
- (b) If :  $(\frac{1}{2}x, 3) = (2, y)$  , then  $x = \dots$  ,  $y = \dots$
- (c) A rhombus of area  $48 \text{ cm}^2$  , its height =  $4.8 \text{ cm}$ .  
 , then its perimeter = ..... cm.
- (d) The lengths of two adjacent sides of a parallelogram are  $x$  and  $y$  ,  
 then its perimeter = .....

3 (a) Write by the list method the set  $X = \{x : x \in \mathbb{N}, 2 \leq x < 7\}$   
 , then represent its elements on the number line.

(b) Solve the equation :  $2x + 5 = 17$  ,  $x \in \mathbb{N}$

- 4 (a) Find the perimeter of the opposite figure.
- (b) Find to the nearest hundredth the area of a parallelogram whose base length is  $34.75 \text{ cm}$ . and its corresponding height  $28.17 \text{ cm}$ .

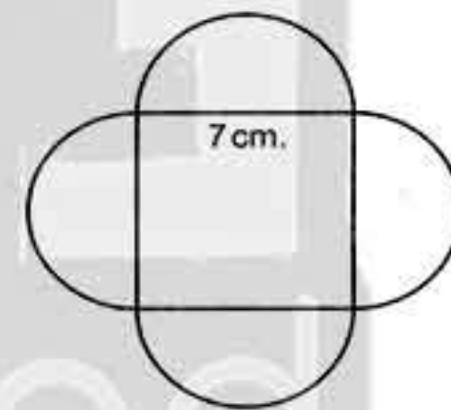

## 5 (a) In the opposite figure complete :

- (1)  $\triangle BEF$  is the image of  $\triangle AEF$  by reflection across .....  
↔
- (2)  $\triangle BDF$  is the image of  $\triangle CDF$  by reflection across .....  
↔
- (3)  $\triangle ABF$  is the image of  $\triangle CBF$  by reflection across .....  
↔
- (4)  $\triangle BEF$  is the image of  $\triangle BDF$  by reflection across .....  
↔

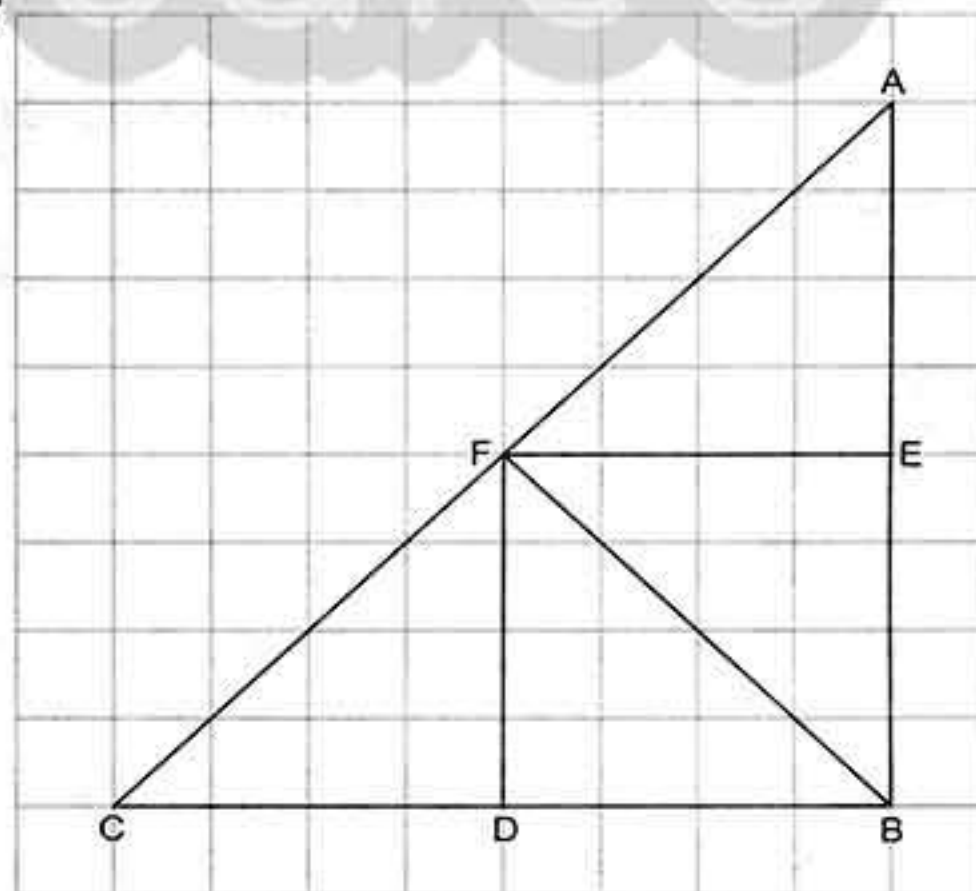



## Final Examinations

- (b) An employee spends his monthly salary as follow 1000 pounds for food. , 500 pounds for clothes , 250 the rent of the flat and 250 other spending. Represent these data on the shown circular sectors.

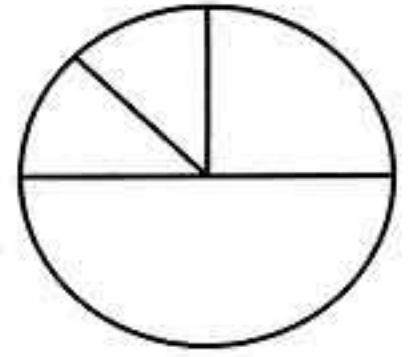

## Model 18



Answer the following questions :

## 1 Choose the correct answer :

- (a)  $(0.3 + 2.7) \dots\dots \mathbb{N}$  ( $\in$  or  $\notin$  or  $\subset$  or  $\supset$ )  
 (b) If :  $(3, x - 2) = (3, 7)$  , then  $x = \dots\dots$  ( 7 or 9 or 5 or 3 )  
 (c) If :  $x + 2 = 5$  ,  $x \in \mathbb{N}$  , then  $x = \dots\dots$  ( 2 or 3 or 5 or 4 )  
 (d)  $\mathbb{N} - \mathbb{E} = \dots\dots$  ( $\mathbb{N}$  or  $\mathbb{O}$  or  $\mathbb{E}$  or  $\mathbb{P}$ )

## 2 Complete the following :

- (a) The multiplicative neutral element in natural numbers plus 9 =  $\dots\dots$   
 (b) If :  $15 \times 34 = (5 + 10) \times x$  , then  $x = \dots\dots$   
 (c) The number of axes of symmetry of square =  $\dots\dots$   
 (d) The length of the base of a triangle whose area is  $240 \text{ cm}^2$  and its height = 10 cm is  $\dots\dots$

## 3 In the opposite figure :

ABCD is a parallelogram in which  
 $AD = 24 \text{ cm}$  , E is the midpoint of  $\overline{AD}$   
 $BF = 15 \text{ cm}$  , the area of  $\triangle ABE = 60 \text{ cm}^2$

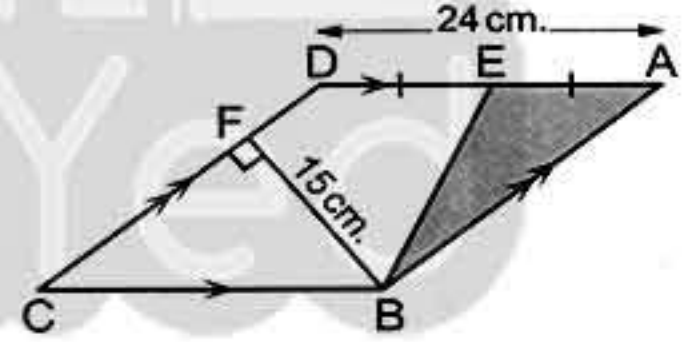

Find :

- (1) The area of the parallelogram ABCD  
 (2) The length of  $\overline{AB}$   
 (3) The perimeter of the parallelogram ABCD

4 (a) Using the properties of operations in  $\mathbb{N}$  to find the result of each of the following.

(1)  $(64 + 135 + 36 + 65) \times 17$  (2)  $84 (25 \times 4 + 125 \times 8)$

(b) Solve the equation :  $3x + 8 = 29$

5 (a) In a coordinate plane. Represent the points A (2 , 3) , B (3 , 5) and C (5 , 3) , then find the image of  $\triangle ABC$  by reflection in  $\overline{AC}$





- (b) A librarian made an inventory of the books in his library and their types. He found the following :  $\frac{1}{4}$  of the books are religious,  $\frac{1}{4}$  of the books are literary,  $\frac{1}{2}$  of the books are scientific.  
Graph that given data using a pie graph. If the total of books was 800 Find the number of each type of books.

## Model 19



Answer the following questions :

## 1 Choose the correct answer :

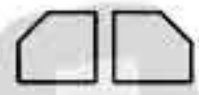
- (a)  $\{2, 7\} \dots\dots \mathbb{N}$ . (  $\in$  or  $\notin$  or  $\subset$  or  $\supset$  )  
 (b) The area of the largest rectangle whose perimeter is 24 cm. =  $\dots\dots$  cm<sup>2</sup>  
 ( 32 or 36 or 72 or 144 )  
 (c) If the side length of a rhombus is  $x$ , its perimeter is  $P$ , the mathematic relation between  $x$  and  $P$  is  $x = \dots\dots$   
 (  $4P$  or  $P+4$  or  $P \div 4$  or  $P-4$  )  
 (d) The type of the opposite transformation is  $\dots\dots$    
 ( translation or reflection or rotation )

## 2 Complete the following :

- (a) The smallest natural number is  $\dots\dots$   
 (b) Odd number + even number =  $\dots\dots$  number.  
 (c) If :  $(4, 7) = (2a, b-1)$ , then  $a = \dots\dots$ ,  $b = \dots\dots$   
 (d) If :  $(x+2) \times 15 = 8 \times 15$ , then  $x = \dots\dots$

- 3 (a) The lengths of the diagonals of a rhombus are 12 cm. and 16 cm. and its height is 9.6 cm. Find its side length.  
 (b) Use the properties of operations in  $\mathbb{N}$  to find the value of.  
 (1)  $25 \times 38 \times 4$  (2)  $44 + 66 + 56 + 34$

- 4 (a) Zahraa saved 14 pounds, she bought 3 notebooks of  $x$  pound for each. The remainder with her was 8 pounds. Express these situations by an equation.

- (b) Calculate the perimeter of the opposite figure where  
 $AM = 35$  cm. ( $\pi = \frac{22}{7}$ )

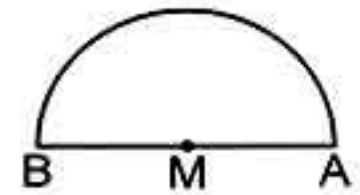

## 5 (a) On the coordinate plane :

Graph the points  $(4, 3)$ ,  $(4, 9)$ ,  $(7, 9)$  and  $(7, 3)$  join them in the same order and name the figure you obtained.



## Final Examinations

(b) Represent the following distribution by frequency polygon :

Sets	0 -	2 -	4 -	6 -	8 -
Frequency	3	7	8	9	2

## Model 20



Answer the following questions :

1 Choose the correct answer :

- (a) The number of axes of symmetry of square = .....  
( 0 or 1 or 2 or 4 )
- (b) If :  $x + 3 = 5$  ,  $x \in \mathbb{N}$  , then  $x = \dots\dots\dots$  ( 1 or 2 or 3 or 4 )
- (c) If we multiply the number  $x$  by 7 , then we subtract from the result 3 we shall get ..... (  $7x + 3$  or  $3x + 7$  or  $7x - 3$  or  $x - 21$  )
- (d) 1 , 4 , 9 , 16 , ..... ( 23 or 24 or 25 or 20 )

2 Complete the following :

- (a) The circumference of a circle with radius lengths 10 cm. is .....  $\pi$  cm.
- (b) If :  $x = \{x : x \in \mathbb{N} , 2 \leq x < 7\}$  , then  $x = \{ \dots\dots\dots \}$
- (c) The least natural number is .....
- (d) The type of the opposite transformation is .....

3 (a) Use the properties of addition to find the value of :

$$38 + 47 + 62 + 53$$

(b) Which is greater in area ?

Triangle whose base length 18 cm. and its height 12 cm. or rhombus with diagonals lengths 24 cm. and 8 cm.

4 (a) Find the radius length of circle which its circumference = 88 cm. ( $\pi = \frac{22}{7}$ )

(b) Solve the equation :  $3x + 5 = 26$

5 (a) In coordinate plane :

Draw the triangle ABC where A (1 , 3) , B (4 , 1) , C (4 , 7) , then draw the image of triangle ABC by reflection in  $\overline{BC}$

(b) The following table represents the marks of pupils in maths test , represent these data by a frequency polygon.

Sets	5 -	10 -	15 -	20 -	25 -
Frequency	5	10	17	7	2





## Model 21



Answer the following questions :

**1** Choose the correct answer :

- (a)  $\{2, 3, 0.3\} \dots \mathbb{N}$  ( $\subset$  or  $\in$  or  $\not\subset$  or  $\notin$ )  
 (b)  $\mathbb{N} - \mathbb{E} = \dots$  ( $\mathbb{E}$  or  $\mathbb{O}$  or  $\mathbb{P}$  or  $\mathbb{N}$ )  
 (c) The number of axes of symmetry of the rectangle = .....  
 (0 or 1 or 2 or 4)  
 (d) If :  $x - 3 = 7$ ,  $x \in \mathbb{N}$ , then  $x = \dots$  (4 or 3 or 10 or 21)

**2** Complete the following :

- (a) The width of a rectangle is  $x$  cm. its length is longer than twice its width by 3 cm. , then the length of the rectangle is ..... cm.  
 (b) The number 5 lies on the right of the number ..... directly and on the left of the number .....  
 (c) The area of a rhombus whose diagonals are 6 cm. and 8 cm. is .....  $\text{cm}^2$   
 (d) If : A (5 , 7) and B (3 , 7) , then C ( ..... , ..... ) is the midpoint of  $\overline{AB}$

**3** (a) The opposite figure shows a football playground.

Find the distance around the figure when  $\pi = \frac{22}{7}$

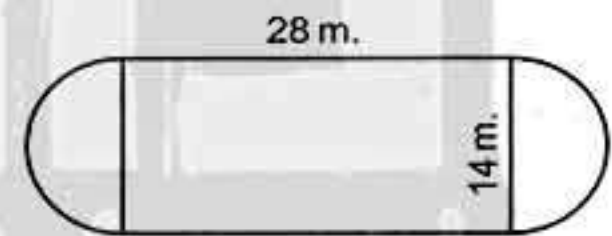

- (b) Use operations properties in  $\mathbb{N}$  to calculate :  $25 \times 781 \times 4$

**4** (a) Solve these equations :

(1)  $k - 72 = 72$                       (2)  $6n = 48$

(b) In the opposite figure :

ABCD is a parallelogram in which  
 $AB = 10$  cm. ,  $DE = 12$  cm. ,  $DF = 8$  cm.

Find : (1) The area of the parallelogram ABCD  
 (2) The length of  $\overline{BC}$

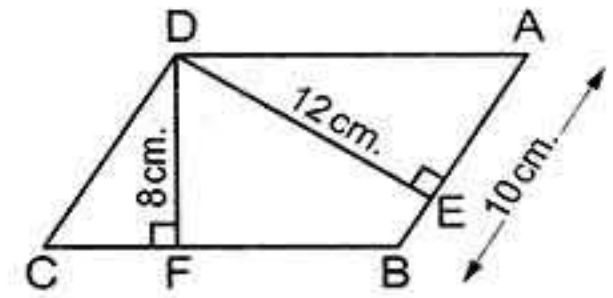

**5** (a) In the two dimensions cartesian coordinates :

Determine the points A (2 , 5) , B (5 , 2) and C (5 , 8) , then find the length of  $\overline{BC}$  by measuring.



## Final Examinations

(b) The following table shows the marks of 40 pupils in mathematics exam.

(1) Find the value of A.

(2) Draw the frequency histogram and frequency polygon which represent these data.

Sets	10 –	20 –	30 –	40 –	50 –	Total
Frequency	6	5	12	A	9	40

## Model 22



Answer the following questions :

1 Choose the correct answer :

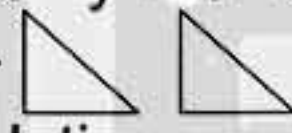
- (a)  $(5 - 7) \dots\dots N$  ( $\in$  or  $\notin$  or  $\subset$  or  $\not\subset$ )  
 (b) The least prime number  $\times$  any prime number =  $\dots\dots$  number.  
 (odd or even or prime or otherwise)  
 (c) Twice the number  $y$  subtracted from it 4 the symbolic expression for this situation is  $\dots\dots$  ( $y - 4$  or  $2y - 4$  or  $y + 4$  or  $2y + 4$ )  
 (d) The type of the opposite transformation is  $\dots\dots$    
 (rotation or translation or reflection)

2 Complete the following :

- (a) If : A (3 , 7) and B (5 , 7) , then AB =  $\dots\dots$  length unit.  
 (b) If :  $x$  is an odd number , then  $x + 2$  is  $\dots\dots$  number.  
 (c) The circumference of a circle with diameter 21 cm. is  $\dots\dots$  ( $\pi = \frac{22}{7}$ )  
 (d) The perimeter of the equilateral triangle whose side length is  $l$  cm. =  $\dots\dots$

3 (a) Using the properties of commutation , distribution and association. Find the value of each of the following :

(1)  $8 \times 731 \times 125$

(2)  $28 + 59 + 72$

(b) The age of a man now  $x$  years where  $x \in \mathbb{N}$  Find :

(1) The age of the man after 9 years.

(2) The age of the man since 8 years.

4 In 2-dimensional coordinate plane locate the points A (2 , 0) , B (4 , 0) , C (0 , 5) and D (0 , 3). Find the area of the shape ABCD

5 (a) If the area of the square =  $72 \text{ cm}^2$  Find the length of its diagonal.





(b) Represent the following distribution by frequency polygon :

Sets	0 -	4 -	8 -	12 -	16 -
Frequency	7	3	10	12	4

### Model 23



Answer the following questions :

1 Choose the correct answer :

- (a) The set of even numbers ..... the set of natural numbers.  
(  $\subset$  or  $\in$  or  $\not\subset$  or  $\notin$  )
- (b) If  $x$  is an odd number , then  $x + 3$  is ..... number.  
( odd or even or prime )
- (c) The number of axes of symmetry of the rhombus equals .....  
( zero or 1 or 2 or 4 )
- (d) If :  $x = \{x : x \in \mathbb{N}, 2 \leq x < 4\}$  , then  $x =$  .....  
(  $\{3\}$  or  $\{2, 3\}$  or  $\{2, 3, 4\}$  or  $\{2\}$  )

2 Complete the following :

- (a) The least number in the set of counting numbers is .....
- (b) The sum of two numbers is 20 one of them is  $x$  , then the other = .....
- (c) If : A (2 , 3) and B (2 , 7) the length of  $\overline{AB} =$  ..... length unit.
- (d) The area of the square =  $\frac{1}{2} \times$  .....

3 (a) Which is greater in area ?

The triangle whose base length is 12 cm. and its corresponding height = 8 cm. or the parallelogram in which the length of the base = 10 cm. and its corresponding height = 5 cm.

(b) Solve the following equation :

- (1)  $x + 3 = 17 \quad x \in \mathbb{N}$   
(2)  $2x + 7 = 23 \quad x \in \mathbb{N}$

4 (a) Use the properties of operation in  $\mathbb{N}$  to find the result of each (write the used property)

- (1)  $156 + 871 + 344 + 129$                       (2)  $27 (25 \times 4 + 125 \times 8)$

(b) A jam jar has form of a cylinder its base is a circle with diameter lengths 7 cm. Find the circumference of its flat base.



## Final Examinations

## 5 (a) In the coordinate plane :

Draw the triangle ABC in which A (5 , 5) , B (2 , 5) and C (3 , 7) , then draw the image of triangle ABC by reflection in  $\overline{AB}$

- (b) 220 candidates have applied for a test to hire male and female anchor persons in the television. If the opposite pie graph represents the given data ; what is the number of female candidates who applied for that test ?

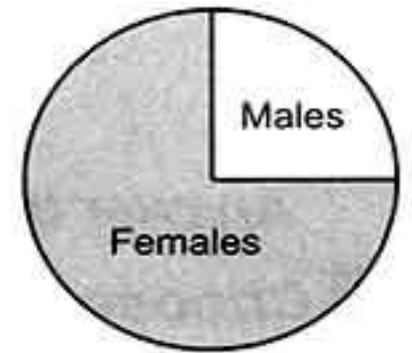

## Model 24



Answer the following questions :

## 1 Choose the correct answer :

- (a)  $(x - 10)$  .....  $(x - 9)$  where  $x$  is a natural number more than 17  
( > or < or = or  $\geq$  )
- (b) The type of the opposite transformation is .....   
( reflection or rotation or translation )
- (c) The number of axes of symmetry of the parallelogram = .....  
( 0 or 1 or 2 or 4 )
- (d) If :  $x - 3 = 5$  ,  $x \in \mathbb{N}$  , then  $x =$  .....  
( 8 or 2 or 6 or 7 )

## 2 Complete the following :

- (a) If :  $945 = (x \times 100) + 45$  , then  $x =$  .....
- (b) If we subtract 8 from twice the number  $z$  , then we shall get the number .....
- (c)  $\frac{\text{The circumference of the circle}}{\text{The length of its diameter}} =$  .....
- (d) 1 , 1 , 2 , 3 , 5 , 8 , ..... , ..... (in the same pattern)

## 3 (a) In the opposite figure :

ABCD is a parallelogram in which  
AD = 18 cm. , CD = 12 cm. ,  $\overline{DF} \perp \overline{BC}$   
, DF = 10 cm. and  $\overline{DE} \perp \overline{AB}$   
, calculate the length of  $\overline{DE}$

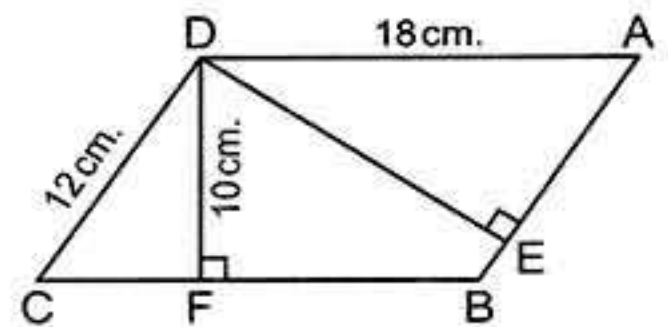





(b) *In the opposite figure :*

The length of the diameter  $\overline{AB}$  of a semicircle is 14 cm.

Find the distance around the figure ( $\pi = \frac{22}{7}$ )

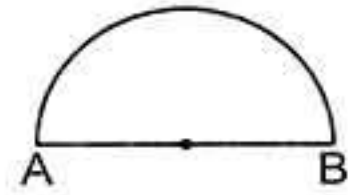

4 (a) *Use the properties of operations to find the result of :*

(1)  $38 + 47 + 62 + 53$

(2)  $8 \times 37 \times 125$

(b) *Translate each verbal statement into an equations :*

(1) A number if added to 17 the sum is 28

(2) If 9 is subtracted from a number , then the result is 23

5 (a) Draw  $\Delta ABC$  where A (2 , 5) , B (5 , 2) and C (5 , 8) , then find its image by reflection a cross  $\overline{BC}$

(b) *Represent the following distribution by frequency polygon :*

Sets	5 -	7 -	9 -	11 -	13 -
Frequency	4	12	10	7	8

### Model 25



*Answer the following questions :*

1 *Choose the correct answer :*

(a) If : E is the set of even numbers , then E .....  $\mathbb{N}$   
(  $\in$  or  $\notin$  or  $\subset$  or  $\not\subset$  )

(b) The multiplicative identity element in  $\mathbb{N}$  is .....  
( 0 or 1 or 2 or 4 )

(c) The sum of any two natural numbers .....  $\mathbb{N}$   
(  $\in$  or  $\notin$  or  $\subset$  or  $\not\subset$  )

(d) The number of axes of symmetry of an isosceles triangle = .....  
( 0 or 1 or 2 or 3 )

2 *Complete the following :*

(a) If : A (2 , 5) and B (4 , 5) , then the midpoint of  $\overline{AB}$  is the point ( ..... , ..... )

(b) If :  $3x = 21$  , then  $x =$  .....

(c) Double the number  $x$  subtracted 8 from it equals .....

(d) The square whose area is  $32 \text{ cm}^2$  the length of its diagonal = ..... cm.



## Final Examinations

- 3 (a) Use the commutative and associative property to find the value of :  $4 \times 72 \times 25$
- (b) Graph the figure ABCD where A (2 , 8) , B (3 , 4) , C (8 , 4) and D (7 , 8) what is the name of the figure ABCD ?

- 4 The opposite figure shows a football playground find the distance around the figure when  $(\pi = \frac{22}{7})$

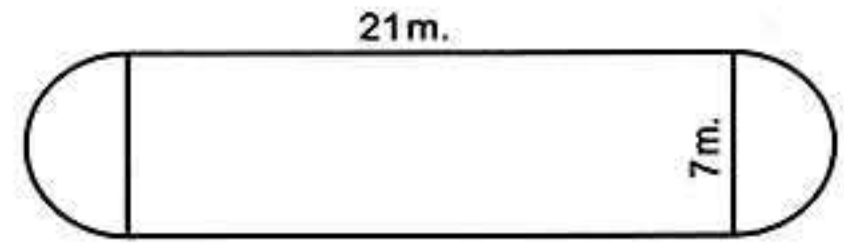

- 5 (a) Solve the equation :  $\frac{1}{3}x - 2 = 8$
- (b) The following table shows the number of students who practice sports. Represent these data using pie graph on the opposite figure :

Game	Football	Basketball	Volleyball
Number	20	10	10

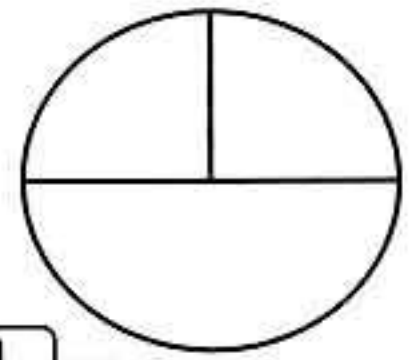



## Some Schools' Examinations from Different Governorates

### 1 Cairo Governorate

Western Cairo Educational Zone  
City Language School



Answer the following questions :

#### 1 Choose the correct answer :

- [a] If  $x + 8 = 15$  ,  $x \in \mathbb{N}$  , then  $x =$  .....  
( 3 or 7 or 6 or 5 )
- [b] The number of axes of symmetry of the rhombus .....  
( 1 or 2 or 3 or 4 )
- [c] If  $2x = 6$  , then  $x =$  .....  
( 5 or 1 or 4 or 3 )
- [d] The area of a triangle whose base length is 10 cm. and the corresponding height is 5 cm. = .....  $\text{cm}^2$   
( 50 or 15 or 25 or 5 )

#### 2 Complete the following :

- [a]  $7 \times 15 = 15 \times a$  , then  $a =$  .....
- [b] The sum of two numbers is 21 one of them  $x$  , then the other = .....
- [c] The perimeter of the square whose side length is  $L$  cm. = ..... cm.
- [d] The area of the parallelogram = .....  $\times$  .....

#### 3 [a] Solve the following equation :

$$3x - 5 = 10 , x \in \mathbb{N}$$

- [b] **Complete** : Twice the number  $x$  subtracted 8 from it = .....

#### 4 [a] The square whose diagonal length is 6 cm. Find its area.

- [b] In the orthogonal Cartesian co-ordinates determine the points A (2 , 5) , B (5 , 2) and C (5 , 8)  
, then draw its image by reflection in  $\overleftrightarrow{BC}$

#### 5 [a] The circle whose diameter length is 14 cm.

Find its circumference. ( $\pi = \frac{22}{7}$ )



[b] The following table shows the frequency distribution of the number of work hours of 50 workers :

Sets	4 –	6 –	8 –	10 –	Total
Frequency	12	8	16	14	50

Draw the frequency polygon which represent these data.

### Additional question

Choose the correct answer :

- [a] If  $X = \{x : x \in \mathbb{N}, 3 \leq x < 5\}$ , then  $x = \dots\dots\dots$   
 ( {3} or {4} or {3, 4} or {3, 4, 5} )
- [b] 25  $\dots\dots\dots$   $\mathbb{N}$  (  $\subset$  or  $\not\subset$  or  $\notin$  or  $\in$  )
- [c] The smallest natural number is  $\dots\dots\dots$  ( 0 or 1 or 2 or 3 )
- [d]  $(8 \times 3) \times 5 = \dots\dots\dots \times (3 \times 5)$  ( 3 or 5 or 8 or 35 )

## 2 Cairo Governorate

Rod El-Farag Educational Zone  
St. Mary's School



Answer the following questions :

1 Choose the correct answer :

- [a] The number of lines of symmetry of a rectangle is  $\dots\dots\dots$   
 ( 0 or 2 or 3 or 4 )
- [b] The area of a rhombus whose diagonals 10 cm. , 20 cm. is  $\dots\dots\dots$   $\text{cm}^2$   
 ( 400 or 300 or 200 or 100 )
- [c] If the side length of a square is  $x$  and its perimeter is  $P$   
 , then  $P = \dots\dots\dots$  (  $4x$  or  $x+4$  or  $x-4$  or  $4-x$  )
- [d] The area of a square whose diagonal length 6 cm. is  $\dots\dots\dots$   $\text{cm}^2$   
 ( 18 or 36 or 12 or 24 )

2 Complete :

- [a] If the diameter of a circle is 14 cm. ,  $\pi = \frac{22}{7}$   
 , then its circumference =  $\dots\dots\dots$  cm.
- [b] The number of axes of symmetry of the rhombus equals  $\dots\dots\dots$



## Final Examinations

[c] If  $x + 3 = 12$ , then  $x = \dots\dots\dots$

[d] Shorouk saved L.E.  $y$  and her father gave her L.E. 12, then she has L.E.  $\dots\dots\dots$

3 [a] In the opposite figure :

Find the perimeter of the figure  
where  $\pi = \frac{22}{7}$



[b] Ahmed has L.E.  $x$ , Samir has L.E. 10 and the sum of what Samir has and the twice of what Ahmed has is L.E. 24. Write an equation to represent this situation and find the value of  $x$ .

4 [a] In a square shaped piece of land with diagonal length 28 m., a square shaped house with side length 15 m. has been built on it and the left part was used as a garden. Find the area of the garden.

[b] In a 2-dimensional coordinate plan, draw  $\triangle ABC$  where  $A(2, 5)$ ,  $B(5, 2)$  and  $C(5, 8)$ , then find its image by reflection across  $\overleftrightarrow{BC}$ .

5 [a] Which is greater in area? A triangle whose base length = 9 cm. and height = 8 cm. or parallelogram in which the length of the base = 8 cm. and its height = 6 cm.

[b] The following table shows the daily wages of workers in a company :

Sets	20 –	30 –	40 –	50 –	60 –	Total
Frequency	8	10	16	12	4	50

Draw the frequency histogram and frequency polygon which represent these data.

## Additional question

Complete :

[a] The multiplicative neutral element in  $\mathbb{N}$  is  $\dots\dots\dots$

[b] The sum of two odd numbers is  $\dots\dots\dots$  number.

[c] 1, 4, 8, 13,  $\dots\dots\dots$ ,  $\dots\dots\dots$  ( in the same pattern )

[d]  $74 \times (73 + 27) = 74 \times \dots\dots\dots = \dots\dots\dots$



## 3 Cairo Governorate

El-Zeitoun Educational Zone  
El-Ma'arof Modern Lang. School

Answer the following questions :

## 1 Choose the correct answer :

[a] Subtracting 3 from double of the number  $x = \dots\dots\dots$ (  $x - 3$  or  $2x - 3$  or  $3x + 2$  or  $5x$  )[b] If  $x + 3 = 12$  , then the value of  $x = \dots\dots\dots$ 

( 12 or 4 or 15 or 9 )

[c] The area of a square whose diagonal length is 8 cm. =  $\dots\dots\dots$  cm<sup>2</sup>

( 64 or 32 or 16 or 8 )

[d] Circumference of the circle =  $\dots\dots\dots$ (  $\pi r^2$  or  $2\pi r^2$  or  $\frac{1}{2}\pi r^2$  or  $2\pi r$  )[e] The number of symmetry axes of an equilateral triangle =  $\dots\dots\dots$ 

( 0 or 1 or 2 or 3 )

## 2 Complete :

[a] A rhombus of area 48 cm<sup>2</sup> , its height = 4.8 , then its perimeter =  $\dots\dots\dots$  cm.[b] If  $7 \times 15 = 15 \times x$  , then  $x = \dots\dots\dots$ [c] The sum of two numbers is 35, one of them is  $x$  , then the other is  $\dots\dots\dots$ [d] The square whose perimeter is 32 cm. , its area =  $\dots\dots\dots$  cm<sup>2</sup>[e] The base length of a triangle is 8 cm. and its height 5 cm. , then its area =  $\dots\dots\dots$  cm<sup>2</sup>

## 3 [a] In the opposite figure :

ABCD is a square , its perimeter is 60 cm. ,  $E \in \overline{BC}$  and  $BE = 35$  cm.  
Find the area of the figure ABED

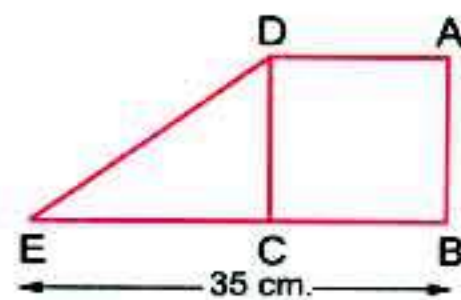

## [b] Solve the equations :

(1)  $3x + 8 = 29$

(2)  $\frac{1}{3}x + 8 = 10$



## Final Examinations

## 4 [a] Which is greater in area ?

A rhombus in which the lengths of its diagonals 6 cm. , 8 cm.  
or a parallelogram whose base length is 7 cm. and height 4 cm.

[b] In the orthogonal Cartesian-coordinates locate the points  
A (8 , 2) , B (3 , 2) , C (3 , 6) , D (8 , 6) then complete :

- (1) The length of AB = ..... units, the length of BC = ..... units.  
(2) The figure ABCD is .....  
(3) The perimeter of the figure ABCD = ..... units.

## 5 The following table shows the daily wages of workers in a company :

Sets	20 –	30 –	40 –	50 –	60 –	Total
Frequency	8	10	16	12	4	50

Draw the frequency histogram and frequency polygon which represent these data.

## Additional question

Use the commutative , associative properties to simplify finding the result of :

(1)  $98 + 175 + 102$

(2)  $4 \times 175 \times 25$

## 4 Cairo Governorate

El-Nozha Directorate of Education  
Our Lady of Perpetual Succour School



Answer the following questions :

## 1 Choose the correct answer :

[a] If  $x + 7 = 19$  ,  $x \in \mathbb{N}$  , then  $x =$  .....

( 26 or 12 or 11 or 13 )

[b] If the longest chord in a circle is 7 cm. , then the circumference  
of the circle is ..... cm. where  $(\pi = \frac{22}{7})$

( 3.5 or 7 or 22 or 44 )

[c] A rhombus in which the lengths of its diagonals are 10 cm., and 12 cm.  
Its area = .....  $\text{cm}^2$

( 120 or 60 or 24 or 32 )

[d] Twice the number  $x$  subtracted 7 from it = .....

(  $7 - x$  or  $2x - 7$  or  $7x + 2$  or  $14x$  )



**2 Complete the following :**

- [a] The number of axes of symmetry of the rhombus = .....
- [b] If  $3x = 15$ ,  $x \in \mathbb{N}$ , then  $x = \dots\dots\dots$
- [c] The length of the diagonal of a square with area  $18 \text{ cm}^2 = \dots\dots\dots$
- [d] A parallelogram in which the lengths of two adjacent sides are 5 cm. and 7 cm., the length of the smaller height = 4 cm. , then its area = .....  $\text{cm}^2$

**3 [a] Which is greater in area ?**

A square whose diagonal length is 10 cm. or a right - angled triangle in which the lengths of the sides of the right angle are 8 cm. and 15 cm.

- [b] Solve :  $2x + 9 = 21$  ,  $x \in \mathbb{N}$

**4 [a] In the opposite figure :**

The length of the diameter  $\overline{AB}$  of a semicircle is 14 cm.

Find the distance around the figure ( $\pi = \frac{22}{7}$ )

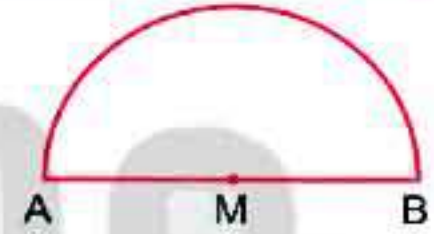

- [b] Draw the triangle ABC where A (2 , 5) , B (5 , 2) and C (5 , 8) , then find its image by reflection across  $\overleftrightarrow{BC}$

**5 [a] If the area of a rhombus is  $30 \text{ cm}^2$  and the length of one of its diagonals is 6 cm. Find the length of the other diagonal.**

- [b] The following table shows the frequency distribution of the number of work hours of 50 workers :

Sets	4 –	6 –	8 –	10 –	Total
Frequency	12	8	16	14	50

Draw the frequency histogram which represents these data.

**Additional question****Complete :**

- [a] The set  $\{a : a \in \mathbb{N}, a < 4\}$  in the listing method = .....
- [b] The property used in :  $a \times (b \times c) = (a \times b) \times c$  is .....
- [c] The additive neutral element in  $\mathbb{N}$  is .....
- [d] 1 , 2 , 3 , 5 , 8 , ..... , ..... (in the same pattern)



## Final Examinations

## 5 Cairo Governorate

New Cairo Educational Zone  
Akhnaton Egyptian College

Answer the following questions :

## 1 Complete :

- [a] If the long base of parallelogram is 8 cm., short base 5 cm. and its short height is 4 cm. , then its area = ..... cm<sup>2</sup>
- [b] The circumference of circle whose diameter length 7 cm. is ..... cm. ( $\pi = \frac{22}{7}$ )
- [c] The area of rhombus =  $\frac{1}{2} \times \dots \times \dots$
- [d] If  $2x = 10$  , then  $x = \dots$
- [e] The polygon ABCD  $\cong$  the polygon XYZL , then  $\angle A \cong \angle \dots$

## 2 Choose the correct answer :

- [a] If the circumference of a circle is 44 cm. , then its radius length = ..... cm. ( 14 or 7 or 22 )
- [b] The triangle whose base length is 5 cm. , and the corresponding height of it is 6 cm. , its area = ..... cm<sup>2</sup> ( 30 or 15 or 25 )
- [c] The area of the square with diagonal length 6 cm. is ..... cm<sup>2</sup> ( 36 or 18 or 12 )
- [d] If  $x + 8 = 15$  ,  $x \in \mathbb{N}$  , then  $x = \dots$  ( 3 or 7 or 6 )
- [e] The shaded triangle is an image of the other triangle by .....   
( reflection or translation or rotation )

## 3 Solve the equations :

[a]  $2x + 9 = 21$  ,  $x \in \mathbb{N}$

[b]  $x - 5 = 2$  ,  $x \in \mathbb{N}$

- 4 [a] In the Cartesian co-ordinates plane draw the triangle ABC where A (2 , 1) , B (5 , 1) and C (5 , 5) , then draw the image of the triangle by reflection on  $\overleftrightarrow{BC}$

- [b] Calculate the perimeter of the opposite figure :  
( $\pi = \frac{22}{7}$ )

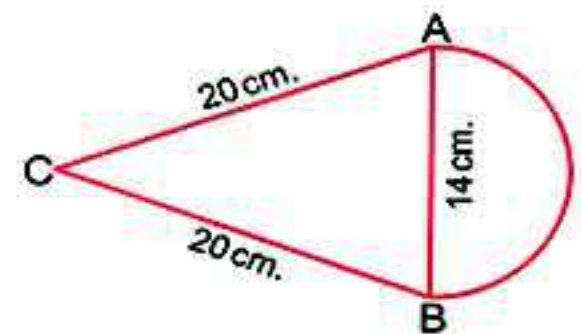



- 5 The following table shows the frequency distribution of the number of work hours of 50 workers :

Sets	4 –	6 –	8 –	10 –	Total
Frequency	12	8	16	14	50

Draw the histogram and the frequency polygon representing these data.

### Additional question

Choose the correct answer :

- [a]  $(4 \times \dots) \times 78 = 7800$  ( 5 or 25 or 50 or 125 )  
 [b] If O is the set of odd numbers , E is the set of even numbers , then  
 $O \cap E = \dots$  (  $\mathbb{N}$  or O or E or  $\emptyset$  )  
 [c]  $(2 + 6) \dots \mathbb{N}$  (  $\in$  or  $\notin$  or  $\subset$  or  $\not\subset$  )  
 [d]  $c \dots a$   where a , c are two natural numbers.  
 ( < or = or > or  $\geq$  )

## 6 Giza Governorate

Bolak El-Dakror Educational Directorate  
Dar El-Hanan language school



Answer the following questions :

- 1 Choose the correct answer :

- [a] If  $x(75 + 10) = 9 \times 85$  , then  $x = \dots$  ( 5 or 85 or 9 or 8 )  
 [b] The number of axes of symmetry of the scalene triangle is .....  
 ( 0 or 1 or 2 or 3 )  
 [c] The length of the base of a triangle whose area is  $240 \text{ cm}^2$  and its height is 10 cm. is ..... cm. ( 4 or 12 or 48 or 240 )  
 [d] Twice the number  $x$  subtracted 3 from it .....  
 (  $x - 3$  or  $2x + 3$  or  $2x - 3$  or  $3 - 2x$  )

- 2 Complete the following :

- [a] The square whose area is  $72 \text{ cm}^2$  , the length of its diagonal = ..... cm.  
 [b] If the age of a man now is  $x$  years , then his age after 7 years = .....  
 [c] If  $5x - 7 = 33$  , then  $x = \dots$   
 [d] The longest chord of a circle is 7 cm. the circumference = ..... cm. where  $(\pi = \frac{22}{7})$



## Final Examinations

**3 [a]** A rhombus in which the lengths of its diagonals are 12 cm. , 16 cm. and the height is 9.6 cm. calculate its area and its side length.

**[b]** In the two dimensions Cartesian co-ordinates, determine the points A (2 , 5) , B (5 , 2) , C (5 , 8) , then :

(1) Find the length of  $\overline{BC}$

(2) Draw its image by reflection across  $\overline{BC}$

(3) Calculate the area of  $\Delta ABC$

**4 [a]** Three times of a number  $x$  is 8 more than 1 , express it in an equation and solve it.

**[b]** Find the perimeter of the opposite figure :

Where  $(\pi = \frac{22}{7})$

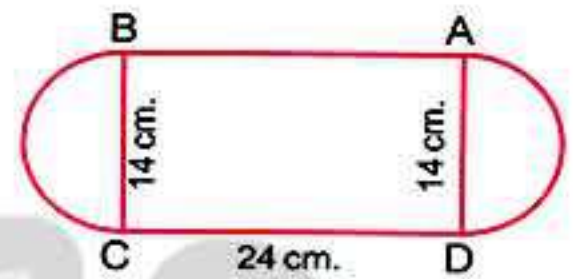

**5 [a]** In the opposite figure :

ABC is a right-angled triangle

AB = 6 cm. , AC = 8 cm. and BC = 10 cm.

Find : (1) Area of  $\Delta ABC$

(2) Length of  $\overline{AD}$

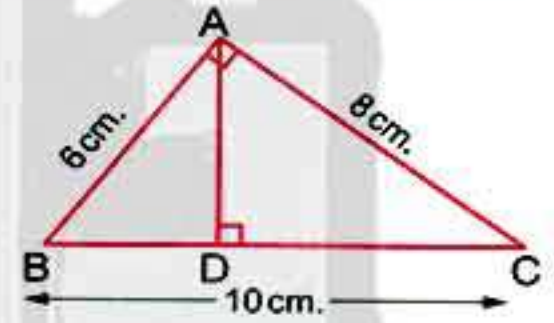

**[b]** The following table shows the frequency distribution of the number of work hours of 50 works :

Sets	2 -	4 -	6 -	8 -	10 -	Total
Frequency	8	9	15	16	2	50

Graph these data using the frequency polygon.

## Additional question

Use the commutative and associative properties in  $\mathbb{N}$  to calculate each of the following :

(1)  $72 + 89 + 28 + 11$

(2)  $8 \times 37 \times 125$



7

Giza Governorate

6<sup>th</sup> October Language School

Answer the following questions :

1 Choose the correct answer :

[a] Adding 8 to double  $x$  the symbolic expression is .....

(  $2x + 8$  or  $8 - 2x$  or  $x + 8$  or  $8 + 3x$  )

[b] The area of rhombus whose diagonals are of length 12 cm. and 16 cm.  
= ..... cm<sup>2</sup> ( 56 or 28 or 96 or 129 )

[c] Isosceles trapezium has ..... line of symmetry.

( 4 or 2 or 1 or 3 )

[d] The circumference of a circle whose diameter is 14 cm.

equals ..... cm. (  $\pi = \frac{22}{7}$  ) ( 44 or 22 or 88 or 100 )

[e] Area of the opposite triangle  
is ..... cm<sup>2</sup>

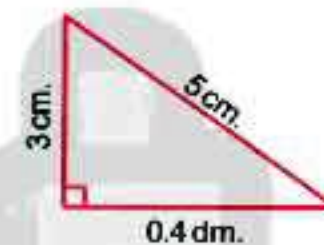

( 12 or 24 or 43 or 6 )

2 [a] Complete the following :

(1) The area of the square whose perimeter is 24 cm. equals ..... cm<sup>2</sup>

(2)  $5x = 10$  , then  $x =$  .....

(3) Square has ..... lines of symmetry.

(4) The image of  $\Delta CAB$

by reflection across  $\overleftrightarrow{BC}$  is  $\Delta$  .....

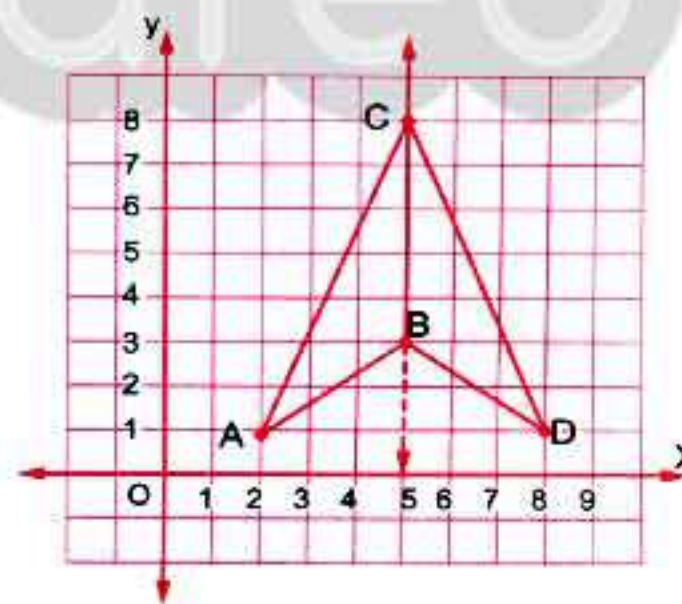

[b] Find the circumference of a circle whose radius length is 35 cm. (  $\pi = \frac{22}{7}$  )

3 Which is greater in area ?

A square whose diagonal is 10 cm. long. or a right-angled triangle in which the lengths of the sides of the right angle are 8 cm. and 15 cm.



## Final Examinations

4 [a] Graph the figure ABCD where A (2 , 7) , B (3 , 4) , C (8 , 4) , D (7 , 7)  
What is the name of the figure ABCD ?

[b] Solve the equation :  $5x + 3 = 13$  where  $x \in \mathbb{N}$

5 The following table shows the recorded temperatures in 40 cities on a day :

Temperatures	20 –	22 –	24 –	26 –	28 –	Total
Number of cities	7	9	11	8	5	40

Represent these data by frequency polygon.

## Additional question

Complete :

[a] The multiplicative identity element in  $\mathbb{N}$  is .....

[b]  $(9 \times 4) \times 3 = \dots \times (3 \times 4)$

[c] The set of natural numbers less than 5 is .....

[d] 1 , 3 , 9 , 27 , ..... , ..... ( in the same pattern )

## 8 Giza Governorate

Maths inspection



Answer the following questions :

1 Choose the correct answer :

[a] If we multiply the number  $x$  by 7 , then we subtract 3 from the result we get .....  
(  $7x + 3$  or  $3x + 7$  or  $7x - 3$  or  $x - 21$  )

[b] If the side length of a rhombus is  $x$  and its perimeter is  $P$  , then the mathematical relation between  $x$  and  $P$  is  $P = \dots$   
(  $x + 4$  or  $4x$  or  $4 - x$  or  $x - 4$  )

[c] The area of the rhombus whose diagonals are of length 12 cm. and 16 cm. = .....  $\text{cm}^2$   
( 56 or 25 or 96 or 192 )

[d] The geometric transformation  is .....  
( translation or rotation or reflection )





**2 Complete the following :**

[a] The shaded triangle is an image of the other triangle by .....

[b] If the perimeter of a square = 32 cm., then its area = ..... cm<sup>2</sup>

[c] If  $x - 3 = 5$  ,  $x \in \mathbb{N}$  , then  $x =$  .....

[d] The area of square whose diagonal length is 12 cm. is ..... cm<sup>2</sup>

**3 [a] Solve the following equation :  $5x - 7 = 33$  ,  $x \in \mathbb{N}$**

[b] In the Cartesian coordinates determine the points A (8 , 5) , B (8 , 2) , C (5 , 2) , D (5 , 7) , then draw the figure ABCD and draw its image by reflection in  $\overleftrightarrow{CD}$

**4 [a] Find the circumference of a circle whose diameter is 14 cm. , ( $\pi = \frac{22}{7}$ )**

[b] *In the opposite figure :*

ABCD is a square of side length 15 cm.

,  $E \in BC$  ,  $BE = 35$  cm.

Find the area of the figure ABED

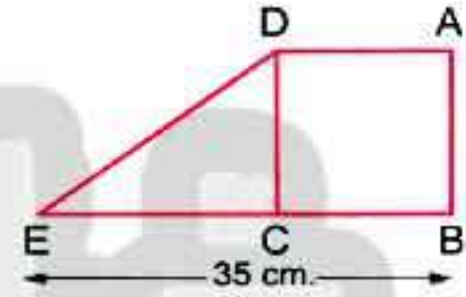

**5 The following table shows the frequency distribution of the number of work hours of 50 workers :**

Sets	4 -	6 -	8 -	10 -	The Total
Frequency	12	8	16	14	50

Draw the frequency polygon to represent these data.

**Additional question**

**Choose the correct answer :**

[a] If O is the set of odd numbers , then  $O$  .....  $\mathbb{N}$

(  $\in$  or  $\notin$  or  $\subset$  or  $\not\subset$  )

[b]  $\{2, 3\}$  .....  $\mathbb{N}$

(  $\in$  or  $\notin$  or  $\subset$  or  $\not\subset$  )

[c] If  $X = \{x : x \in \mathbb{N} , 2 \leq x \leq 3\}$  , then  $X =$  .....

(  $\{2, 3\}$  or  $\{3\}$  or  $\{2\}$  or  $\emptyset$  )

[d] The least prime number  $\times$  any prime number = ..... number.

( odd or even or prime or other wise )



## Final Examinations

## 9 Alexandria Governorate

Middle Educational Zone  
Maths inspection

Answer the following questions :

## 1 Complete :

- [a] The area of a square of diagonal length 8 cm. = ..... cm<sup>2</sup>  
 [b] If  $35 + x = 18 + 35$ , then  $x =$  .....  
 [c] The triangle whose base length is 5 cm. and its corresponding height is 6 cm. then its area = ..... cm<sup>2</sup>  
 [d] The rhombus whose area is 36 cm<sup>2</sup> and the length of one of its diagonals is 8 cm. , then the length of the other diagonal = ..... cm.

## 2 Choose the correct answer :

- [a] If we multiply the number  $x$  by 7 , then we subtract from the result 3 , we shall get .....  
 (  $7x + 3$  or  $3x + 7$  or  $7x - 3$  or  $3 - 7x$  )  
 [b] The area of rhombus whose diagonals 10 cm. and 20 cm. is ..... cm<sup>2</sup> ( 200 or 30 or 100 or 400 )  
 [c] The sum of two numbers a and b is 10, then  $b =$  .....  
 (  $10 - a$  or  $a - 10$  or  $a + 10$  or  $10 - b$  )  
 [d] The diameter length of a circle whose circumference is 44 cm. = ..... cm. (  $\pi = \frac{22}{7}$  ) ( 28 or 21 or 14 or 7 )

- 3 [a] On the coordinate plane, draw  $\triangle ABC$  where A (3 , 5) , B (6 , 5) , C (3 , 2) , then draw the image of  $\triangle ABC$  by reflection across  $\overline{AC}$

## [b] Complete :

- (1) The perimeter of an equilateral triangle whose side length is L cm. = ..... cm.  
 (2) The area of a rectangle whose length is  $x$  cm. and width is 5 cm. = ..... cm<sup>2</sup>

## 4 [a] Solve each of the following equations :

(1)  $3x + 7 = 19$

(2)  $2x - 15 = 7$

- [b] Calculate the perimeter of the following figure

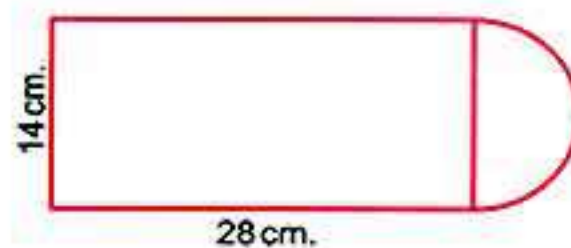
, where (  $\pi = \frac{22}{7}$  )



5 [a] In the opposite figure :

ABC is a right-angled triangle at A,  $\overline{AD} \perp \overline{BC}$   
Find the area of  $\triangle ABC$  and the length of  $\overline{AD}$

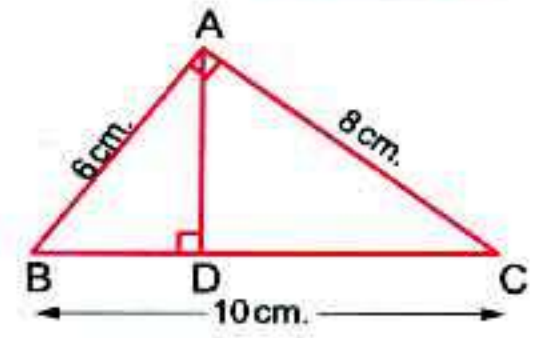

[b] The following table represents the marks of 50 students in the math exam in a month.

Sets	10 –	20 –	30–	40–	Total
Frequency	10	12	18	10	50

Draw the frequency polygon which represents the given data.

### Additional question

[a] Using the properties of addition find the value :  $32 + 47 + 68 + 3$

[b] Use the distribution property in  $\mathbb{N}$  to find :

(1)  $112 \times 99$

(2)  $215 \times 101$

10

## Alexandria Governorate

East Educational Zone  
Supervision of Maths



Answer the following questions :

1 Choose the correct answer :

[a] Subtracting 3 from double of the number  $x = \dots\dots\dots$

(  $x - 3$  or  $2x - 3$  or  $3x + 2$  or  $5x$  )

[b] A square whose diagonal length is 8 cm. , its area =  $\dots\dots\dots$   $\text{cm}^2$

( 8 or 16 or 32 or 64 )

[c] There are  $\dots\dots\dots$  axes of symmetry of an equilateral triangle.

( 0 or 1 or 2 or 3 )

[d] A year and 3 months =  $\dots\dots\dots$  months.

( 13 or 33 or 15 or 27 )

2 Complete :

[a]  $4\frac{2}{5} = \dots\dots\dots$  (as a decimal)

[b] If  $x + 8 = 15$  ,  $x \in \mathbb{N}$  , then  $x = \dots\dots\dots$

[c] The number of axes of symmetry of the rhombus =  $\dots\dots\dots$

[d] A parallelogram whose area is  $36 \text{ cm}^2$  and the length of a side of it = 9 cm. , then the corresponding height to this side =  $\dots\dots\dots$  cm.



## Final Examinations

3 [a] Solve the equations :

(1)  $x - 5 = 19$  ,  $x \in \mathbb{N}$

(2)  $2x + 9 = 21$  ,  $x \in \mathbb{N}$

[b] A rhombus of diagonal lengths are 12 cm. and 16 cm., calculate its area.

4 [a]  $\Delta ABC$  is a right-angled triangle at B , where  $AB = 6$  cm. ,  $BC = 8$  cm. and  $AC = 10$  cm. Find the area of this triangle.

[b] In a 2-dimensional co-ordinate plane , plot the points A (8 , 5) , B (8 , 2) , C (5 , 2) and D (5 , 7). If  $\overleftrightarrow{CD}$  is the axis of reflection of the figure ABCD , then determine the image of ABCD.

5 [a] Calculate the circumference of a circle , if the longest chord in this circle is 7 cm. where  $(\pi = \frac{22}{7})$

[b] Represent the following data by frequency polygon :

Sets	20 –	30 –	40 –	50 –	Total
Frequency	8	10	16	4	50

## Additional question

Complete :

[a] 99 added to the neutral element of multiplication = .....

[b]  $21 + (36 + \dots) = (21 + \dots) + 84$

[c] The set of natural numbers less than 7 and greater than 2 is .....

[d] 1, 4 , 9 , 16, ..... , ..... (in the same pattern)

## 11 El-Kalyoubia Governorate Directorate of Education



Answer the following questions :

1 Complete each of the following :

[a] The square whose diagonal length = 10 cm. , its area = ..... cm<sup>2</sup>

[b] If  $x + 2 = 7$  ,  $x \in \mathbb{N}$  , then  $x - 2 = \dots$

[c] The area of the triangle whose base length is 6 cm. and height 8 cm. = ..... cm<sup>2</sup>

[d]  $\frac{\text{circumference of the circle}}{\text{diameter length}} = \dots$



**2 Choose the correct answer :**

- [a] Number of lines of symmetry of the square = .....  
( 1 or 2 or 3 or 4 )
- [b] Subtracting 9 from twice of the number  $x$  = .....  
(  $2x - 9$  or  $9 - 2x$  or  $2x + 9$  or  $9x$  )
- [c] If  $X = \{x : x \in \mathbb{N}, 5 \leq x < 7\}$ , then  $X =$  .....  
(  $\{5\}$  or  $\{6\}$  or  $\{5, 6\}$  or  $\{5, 6, 7\}$  )
- [d] If the sum of the two numbers  $x$  and  $y$  is 20, then  $y =$  .....  
(  $20 + x$  or  $20 - x$  or  $x - 20$  or  $\frac{x}{20}$  )

**3 [a]** Find the radius length of the circle whose circumference = 132 cm. (Where  $\pi = \frac{22}{7}$ )

- [b] Find the perimeter of the opposite figure :

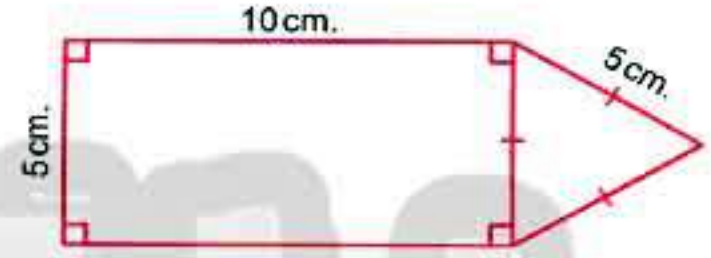
**4 [a]** Solve the equation :  $2x - 5 = 3$ , where  $x \in \mathbb{N}$ 

- [b] In the Cartesian coordinates plane, locate the points  $A(2, 2)$ ,  $B(5, 2)$ ,  $C(5, 6)$  :
- (1) Find the length of each of  $\overline{AB}$  and  $\overline{BC}$
- (2) Draw the image of figure ABC by reflection in  $\overline{BC}$

**5 The following table shows the marks of 40 pupils in maths exam :**

Sets	10 -	20 -	30 -	40 -	Total
Frequency	6	K	14	12	40

- (1) Find the value of K
- (2) Represent these data by the frequency polygon.

**12 El-Sharkia Governorate**

Directorate of Education  
Dep. of Governmental L. Schools



Answer the following questions :

**1 Choose the correct answer :**

- [a] The area of square whose diagonal length is 8 cm. is .....  $\text{cm}^2$   
( 64 or 32 or 16 or 10 )



## Final Examinations

- [b] If  $x + 3 = 8$  ,  $x \in \mathbb{N}$  , then  $x = \dots\dots\dots$  ( 11 or 24 or 13 or 5 )  
 [c] If the sum of two numbers  $x$  and  $y$  is 20 , then  $y = \dots\dots\dots$   
 (  $x - 20$  or  $20 - x$  or  $x + 20$  or  $\frac{x}{20}$  )  
 [d] The square has  $\dots\dots\dots$  symmetric axes. ( 1 or 2 or 3 or 4 )

## 2 Complete the following :

- [a] Area of parallelogram =  $\dots\dots\dots \times \dots\dots\dots$   
 [b] The radius length of circle with circumference 44 cm.  
 and  $\pi = \frac{22}{7}$  is  $\dots\dots\dots$  cm.  
 [c] If  $2x = 10$  and  $x \in \mathbb{N}$  , then  $x = \dots\dots\dots$   
 [d] The length of the base of a triangle whose area =  $80 \text{ cm}^2$   
 and its height = 10 cm. is  $\dots\dots\dots$  cm.

3 [a] Solve the equation in  $\mathbb{N}$  :  $\frac{1}{2}x - 5 = 3$ 

## [b] In the opposite figure :

ABC is a triangle ,  $\overline{CE} \perp \overline{AB}$  ,  
 if  $AB = 6 \text{ cm}$  ,  $BC = 5 \text{ cm}$  ,  
 and  $CE = 4 \text{ cm}$ . Find area of  $\Delta ABC$

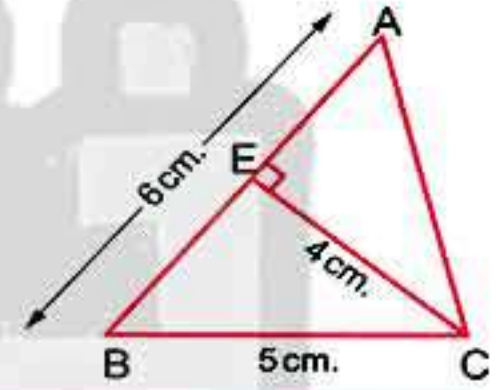

## 4 [a] Calculate the perimeter of the opposite figure

where  $AB = 14 \text{ cm}$ . ( $\pi = \frac{22}{7}$ )

## [b] Which is greater in area ?

a parallelogram of base 10 cm. and corresponding height 6 cm.  
 or a rhombus of diagonals lengths 12 cm. and 16 cm.

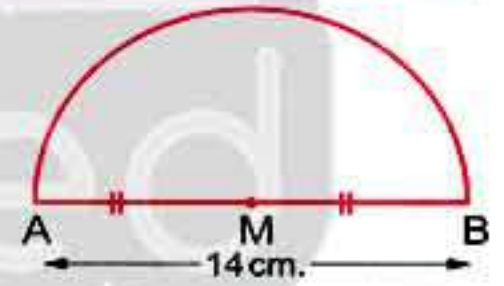

## 5 [a] In 2-dimensional coordinate plane locate the points A (3 , 1)

, B (5 , 1) , C (5 , 3) , D (3 , 3)

Name the figure ABCD , then find its area.

## [b] The following table shows the recorded temperatures in 40 cities on day :

Temperatures	20 -	22 -	24 -	26 -	28 -	Total
Number of cities	7	10	12	6	5	40

Draw each of histogram and the frequency polygon.



## Additional question

Choose the correct answer :

- [a]  $49 \div 8 \dots\dots\dots \mathbb{N}$  ( $\in$  or  $\notin$  or  $\subset$  or  $\not\subset$ )  
 [b] If  $X = \{x : x \in \mathbb{N}, 3 \leq x < 5\}$ , then  $X = \dots\dots\dots$   
 ( $\{4\}$  or  $\{3\}$  or  $\{3, 4\}$  or  $\{4, 5\}$ )  
 [c] If E is the set of even numbers, then  $E \dots\dots\dots \mathbb{N}$   
 ( $\in$  or  $\notin$  or  $\subset$  or  $\not\subset$ )  
 [d]  $(8 \times 3) \times 5 = \dots\dots\dots \times (3 \times 5)$  (3 or 5 or 8 or 15)

## 13 El-Monofia Governorate

El-Bagour Educational Zone  
Maths Inspection

Answer the following questions :

## 1 Complete :

- [a] The perimeter of a square whose side length is  $x$  cm. =  $\dots\dots\dots$  cm.  
 [b] The sum of two numbers is 21 one of them is  $x$ , then the other =  $\dots\dots\dots$   
 [c] The area of a rectangle whose length is  $x$  cm. and width is 5 cm. =  $\dots\dots\dots$  cm<sup>2</sup>  
 [d] The number of axes of symmetry of the rhombus =  $\dots\dots\dots$

## 2 Choose the correct answer :

- [a] Twice the number  $x$  subtracted 3 from it =  $\dots\dots\dots$   
 ( $x - 3$  or  $2x + 3$  or  $2x - 3$  or  $3 - 2x$ )  
 [b] If  $x + 3 = 5$ ,  $x \in \mathbb{N}$ , then :  $x = \dots\dots\dots$  (1 or 2 or 3 or 4)  
 [c] The square whose diagonal length is 8 cm. its area =  $\dots\dots\dots$  cm<sup>2</sup>  
 (64 or 32 or 16 or 8)  
 [d] The length of the base of the triangle is 8 cm. and its height is 5 cm. , then its area =  $\dots\dots\dots$  cm<sup>2</sup> (9 or 40 or 8 or 20)

3 [a] Find the circumference of circle with diameter length 14 cm. ( $\pi = \frac{22}{7}$ )

- [b] Solve the following equation :  $x - 5 = 8$  ,  $x \in \mathbb{N}$

## 4 In the Cartesian co-ordinates plane determine the points

A (2 , 2) , B (5 , 2) , C (5 , 8) , D (2 , 8), if  $\overline{BC}$  is the axis of reflection of the figure ABCD , then determine the image of the figure ABCD



## Final Examinations

5 Draw the frequency polygon for the following frequency distribution :

Sets	10 –	12 –	14 –	16 –	18 –	20 –	Total
Frequency	2	5	7	11	6	4	35

## Additional question

[a] If  $X = \{a : a \in \mathbb{N}, 1 \leq X < 5\}$  ,  $Y = \{4, 5, 6\}$

Find : (1)  $X \cap Y$                       (2)  $X \cup Y$                       (3)  $X - Y$

[b] Use the properties of addition in  $\mathbb{N}$  to find result of :  
 $49 + 257 + 51$  (mention the used property)

## 14 El-Gharbia Governorate

General Mathematics Supervision



Answer the following questions :

1 Complete :

[a] If  $x + 8 = 18$  , then  $x = \dots\dots\dots$

[b] The rhombus with diagonals lengths 6 cm., and 8 cm.  
 its area =  $\dots\dots\dots$  cm<sup>2</sup>

[c] If we add 3 to twice the number  $x$  , then we will get the number  $\dots\dots\dots$

[d] The number of axes of symmetry of the rectangle =  $\dots\dots\dots$

2 Choose the correct answer :

[a] The square whose diagonal length = 8 cm. , its area =  $\dots\dots\dots$  cm<sup>2</sup>  
 ( 64 or 32 or 16 or 8 )

[b] Subtracting 7 from the double of the number  $x = \dots\dots\dots$   
 (  $x - 7$  or  $2x - 7$  or  $7x + 2$  or  $4x$  )

[c] If  $Y \div 10 = 10$  , then  $Y = \dots\dots\dots$  ( 100 or 10 or 1 or 0 )

[d] The square has  $\dots\dots\dots$  lines of symmetry. ( 0 or 1 or 3 or 4 )

3 [a] Find the area of the triangle whose base length is 8 cm. and its corresponding height is 10 cm.

[b] Solve the equation :  $2x - 7 = 5$  where  $x \in \mathbb{N}$

4 [a] On the coordinate plane draw  $\Delta ABC$  where : A (2 , 1) , B (5 , 1) , (5 , 5) , then draw the image of  $\Delta ABC$  by reflection in  $\overline{BC}$

[b] Find the circumference of the circle whose diameter is 7 cm. ( $\pi = \frac{22}{7}$ )



- 5 [a] Solve the equation :  $x + 3 = 12$  where  $x \in \mathbb{N}$   
 [b] Represent the following data by a frequency polygon.

Sets	4 -	6 -	8 -	10 -	Total
Frequency	4	6	5	10	25

### Additional question

Complete :

- [a] The smallest natural number is .....
- [b]  $23 \times (98 + 2) = 23 \times \dots = \dots$
- [c] The set of prime numbers which are less than 15 is .....
- [d]  $(20 \times 50) \times 30 = \dots \times (50 \times 30)$

## 15 El-Dakahlia Governorate

Maths Supervision



Answer the following questions :

- 1 Complete :
- [a] Subtract 3 from the number  $y$ , the symbolic expression is .....
- [b] The perimeter of square whose side length is  $L = \dots$
- [c] The area of the triangle =  $\frac{1}{2} \times \dots \times \dots$
- [d] The area of a parallelogram = .....
- 2 Choose the correct answer :
- [a] If  $x + 8 = 15$  ,  $x \in \mathbb{N}$  , then  $x = \dots$  ( 3 or 7 or 6 or 5 )
- [b] The square whose diagonal length is 8 cm., its area = .....  $\text{cm}^2$   
 ( 64 or 32 or 16 or 8 )
- [c] The number of axes of symmetry of rhombus equals .....
- ( 0 or 1 or 2 or 4 )
- [d] The area of the largest rectangle whose perimeter is 24 cm.  
 = .....  $\text{cm}^2$  ( 15 or 36 or 72 or 144 )
- 3 [a] Which is greater in area ? a rhombus in which the lengths of its diagonals are 8 cm. and 6 cm. or the parallelogram in which the length of its base is 10 cm. and the corresponding height is 5 cm. , then calculate the difference between them.
- [b] Complete : The circumference of a circle = .....



## Final Examinations

4 Find the image of the indicated line segments by reflection across  $L$ , then complete :

- (1) The image of  $\overline{AB}$  by reflection across  $L$  is .....
- (2) The image of  $\overline{EF}$  by reflection across  $L$  is .....
- (3) The image of  $\overline{XY}$  by reflection across  $L$  is .....
- (4) The image of  $\overline{CD}$  by reflection across  $L$  is .....

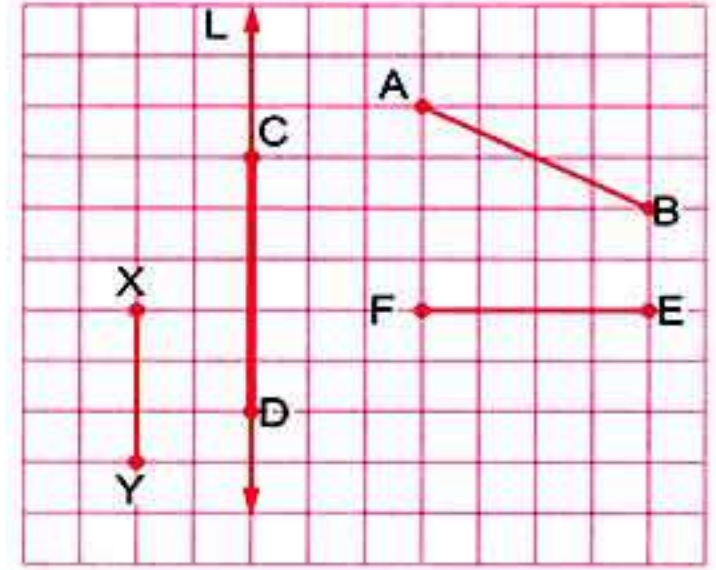

5 [a] An employee spends his monthly salary as follow 1000 pounds for food, 500 pounds for clothes 250 the rent of the flat 250 other spending represent there data on the shown circular sectors.

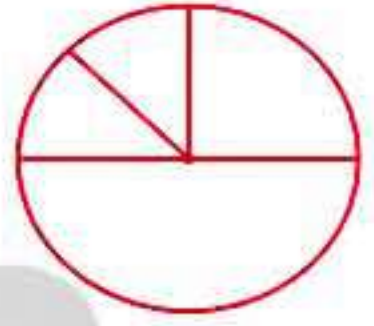

[b] Solve the equation :  $3x + 3 = 12$ , where  $x \in \mathbb{N}$

## Additional question

Choose the correct answer :

- [a]  $\frac{9-5}{3-3} = \dots\dots\dots$  ( zero or 3 or 4 or meaningless )
- [b] The smallest counting number is .....
- [c]  $\{5, 7, 8\} \dots\dots\dots \mathbb{N}$  (  $\subset$  or  $\not\subset$  or  $\in$  or  $\notin$  )
- [d] If  $X = \{x : x \in \mathbb{N}, x \leq 2\}$ , then  $X = \dots\dots\dots$   
(  $\{0, 1\}$  or  $\{1\}$  or  $\{0, 1, 2\}$  or  $\emptyset$  )

## 16 Ismailia Governorate

Directorate of Education  
Directing Mathematics



Answer the following questions :

1 Complete :

- [a] If  $3x = 21$ , then  $x = \dots\dots\dots$
- [b] If  $b = 3$ , then  $2b - 5 = \dots\dots\dots$
- [c] Adding 5 to three times a number  $y$  is .....
- [d] A rhombus its area  $50 \text{ cm}^2$  and the length of one of its diagonals 25 cm, then the length of other diagonal = ..... cm.





2 Choose the correct answer :

- [a] The opposite transformation  is .....  
( translation **or** rotation **or** reflection )
- [b] If the side lengths of a triangle are equal in length then the triangle is ..... triangle. ( scalene **or** isosceles **or** equilateral )
- [c] The angle whose measure 180 is called ..... angle.  
( right **or** obtuse **or** acute **or** straight )
- [d] If  $y = 3x + 5$  , then the constant ..... ( y **or** x **or** 3 **or** 5 )

3 [a] Which is greater in area ? a square its diagonal length 10 cm. or a parallelogram its base length 12 cm. and height 8 cm.

[b] A circle its diameter 21 cm. Find its circumference ( $\pi = \frac{22}{7}$ )

4 [a] In the coordinate plane draw the triangle ABC where A (1 , 1) , B (3 , 1) , C (3 , 5) , then draw its image by reflection on  $\overline{BC}$

[b] Solve the equations :

(1)  $2x + 3 = 13$

(2)  $\frac{1}{2}y = 6$

5 [a] A triangle its area  $48 \text{ cm}^2$  and base length 8 cm. , find the length of its height.

[b] The following table shows the marks of 40 pupils in mathematics exam in one month where the full mark is 50 marks :

Sets	10 –	20 –	30 –	40 –	Total
Frequency	10	12	8	10	40

Represent these data by frequency polygon.

### Additional question

Calculate using commutative , associative and distributive properties :

(1)  $642 + 171 + 358 + 29$

(2)  $25 \times 304$



## Final Examinations

## 17 Suez Governorate

Directorate of Educational  
Maths Inspectorate

Answer the following questions :

## 1 Choose the correct answer :

- [a] If  $x + 3 = 5$  ,  $x \in \mathbb{N}$  , then  $x = \dots\dots\dots$  ( 1 or 2 or 3 or 4 )
- [b] The area of square of diagonal length 6 cm. is  $\dots\dots\dots$  cm<sup>2</sup>  
( 18 or 36 or 24 or 6 )
- [c] The sum of the two numbers a and b is 10 , then b =  $\dots\dots\dots$   
( a - 10 or a or 10 - a or 10 )
- [d] The number of axes of symmetry of the rhombus =  $\dots\dots\dots$   
( 1 or 0 or 3 or 2 )
- [e] If  $X = \{x : x \in \mathbb{N} , 3 \leq x < 5\}$  , then  $x \in \dots\dots\dots$   
( {4} or {3 , 4} or {3} or {4 , 5} )

## 2 Complete :

- [a] Add 5 to twice the number  $x = \dots\dots\dots$
- [b] The triangle of base length 5 cm. and the corresponding height is 6 cm. , its area =  $\dots\dots\dots$  cm<sup>2</sup>
- [c] The number of axes of symmetry of an equilateral triangle is  $\dots\dots\dots$
- [d] The circumference of a circle with diameter 20 cm. is  $\dots\dots\dots$   $\pi$  cm.
- [e] If  $945 = (x \times 100) + 45$  , then  $x = \dots\dots\dots$

3 [a] Solve the equation :  $3x + 7 = 19$  ,  $x \in \mathbb{N}$ 

[b] Find the area of rhombus whose diagonals lengths 20 cm. and 10 cm.

4 [a] Find the circumference of the circle of radius 21 cm. ( $\pi = \frac{22}{7}$ )[b] In 2-dimensional coordinate plane locate the points A (2 , 1) , B (5 , 1) and C (5 , 5) , then draw the image of  $\triangle ABC$  by reflecting across  $\overline{BC}$ 

## 5 [a] Find the area of parallelogram ABCD

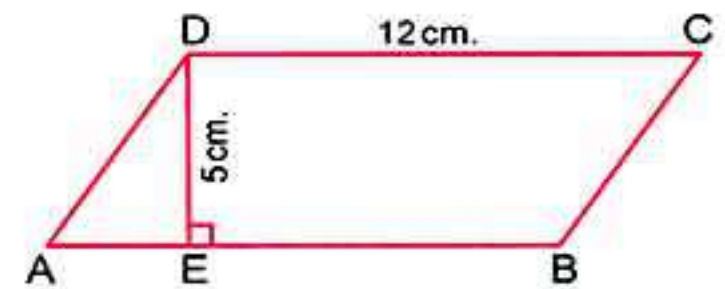



[b] The following table shows the marks of 35 students in math exam :

Sets	5 –	10 –	15 –	20 –	25 –	Total
Frequency	5	9	11	6	4	35

Represent these data by frequency polygon.

## 18 Port Said Governorate

Maths Inspection



Answer the following questions :

1 Choose the correct answer :

[a] If  $x + 7 = 9$ ,  $x \in \mathbb{N}$ , then  $x = \dots\dots\dots$  ( 16 or 2 or 11 or 13 )

[b] The area of a triangle whose base length 5 cm. and the corresponding height 6 cm. is  $\dots\dots\dots$   $\text{cm}^2$   
( 15 or 3 or 11 or 60 )

[c] Subtract 4 from the number  $y$  the symbolic expression is  $\dots\dots\dots$   
(  $2y - 4$  or  $y + 4$  or  $y - 4$  or  $2y + 4$  )

[d] The number of axes of symmetry of the square  $\dots\dots\dots$   
( 1 or 2 or 3 or 4 )

2 Complete the following :

[a] Shorouk saved  $x$  pounds , her father gave her 10 pounds , then she has  $\dots\dots\dots$  pounds.

[b] The area of a rhombus whose diagonals are 6 cm. and 8 cm. is  $\dots\dots\dots$   $\text{cm}^2$

[c] In the opposite figure :

The shaded sector represents  $\dots\dots\dots$  of the circle.

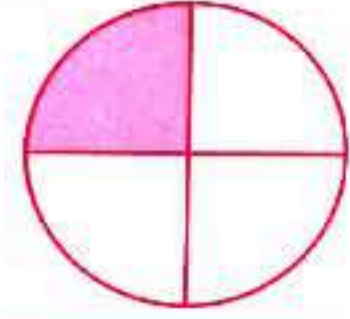

[d] The area of square =  $\frac{1}{2} \times$  diagonal length  $\times \dots\dots\dots$

3 [a] Solve the following equation :  $2x + 9 = 21$  ,  $x \in \mathbb{N}$

[b] In the opposite figure :

ABCD is a parallelogram in which  $AB = 10$  cm.

,  $DE = 12$  cm. ,  $DF = 8$  cm. Find :

(1) The area of the parallelogram ABCD.

(2) The length of  $\overline{BC}$

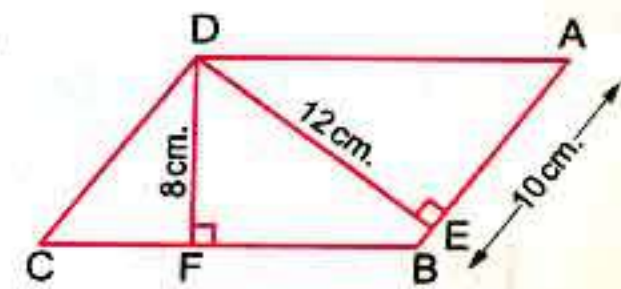



## Final Examinations

- 4 [a] Find the circumference of a circle with diameter 10 cm. ( $\pi = 3.14$ )  
 [b] In the Cartesian coordinates plane, determine the points A (2, 5), B (5, 2) and C (5, 8), then draw the image of  $\Delta ABC$  by reflection in  $\overrightarrow{BC}$

- 5 From the following table draw the histogram and the frequency polygon :

Sets	10 –	20 –	30 –	40 –	Total
Frequency	10	12	18	10	50

## Additional question

Complete :

- (1) The multiplicative neutral element in  $\mathbb{N}$  is .....
- (2) If  $X = \{x : x \in \mathbb{N}, 3 \leq x < 4\}$ , then  $x \in$  .....
- (3) The set of natural numbers less than 7 is .....
- (4)  $32 + (59 + \dots) = (32 + 68) + \dots$

## 19 Damietta Governorate

Damietta Inspection of Mathematic  
Official Language Schools



Answer the following questions :

- 1 Choose the correct answer :

- [a] If the ordered pair  $(2, 5) = (2, y)$ , then  $y =$  .....  
 ( 2 or 3 or 4 or 5 )
- [b] If the sum of two numbers  $x$  and  $y$  is 20, then  $y =$  .....  
 (  $20 + x$  or  $20 - x$  or  $x - 20$  or  $\frac{x}{20}$  )
- [c] Circumference of the circle = .....  
 (  $\pi r$  or  $2\pi r$  or  $\pi$  or  $\pi + r$  )
- [d] The number of axes of symmetry of the rhombus is .....  
 ( 0 or 1 or 2 or 4 )

- 2 Complete :

- [a] A square whose diagonal is 8 cm, then its area = .....  $\text{cm}^2$
- [b] If the number  $x$  is 9 more, then the double of  $y$ , then  $x =$  .....
- [c] If  $x - 4 = 6$ ,  $x \in \mathbb{N}$ , then  $x =$  .....



[d] An employee spends his salary as follows  
 $\frac{1}{8}$  of it to clothes ,  $\frac{1}{2}$  of it to food  
 ,  $\frac{1}{4}$  of it to medicine and  
 $\frac{1}{8}$  of it to renting. If his salary was L.E. 1 600  
 , then the spends of food = L.E. ....

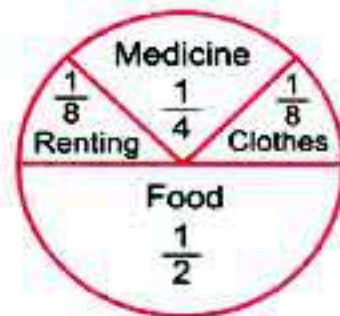

3 [a] In the opposite figure :

ABCD is a parallelogram in which  
 AB = 10 cm. , DE = 12 cm. , DF = 8 cm.

Find : (1) The area of the parallelogram ABCD  
 (2) The length of  $\overline{BC}$

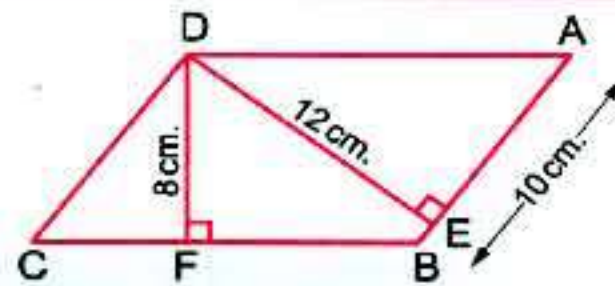

[b] Calculate the circumference of the circle whose diameter  
 is 14 cm. ( $\pi = \frac{22}{7}$ )

4 [a] In the cartesian coordinates plane  
 , from the opposite figure :

(1) Complete : A (..... , .....)  
 , B (..... , .....)  
 and C (..... , .....)  
 (2) If L is the axis of reflection  
 of the  $\Delta ABC$  , draw  $\Delta \hat{A}\hat{B}\hat{C}$   
 the image of  $\Delta ABC$   
 by reflection in the straight line L

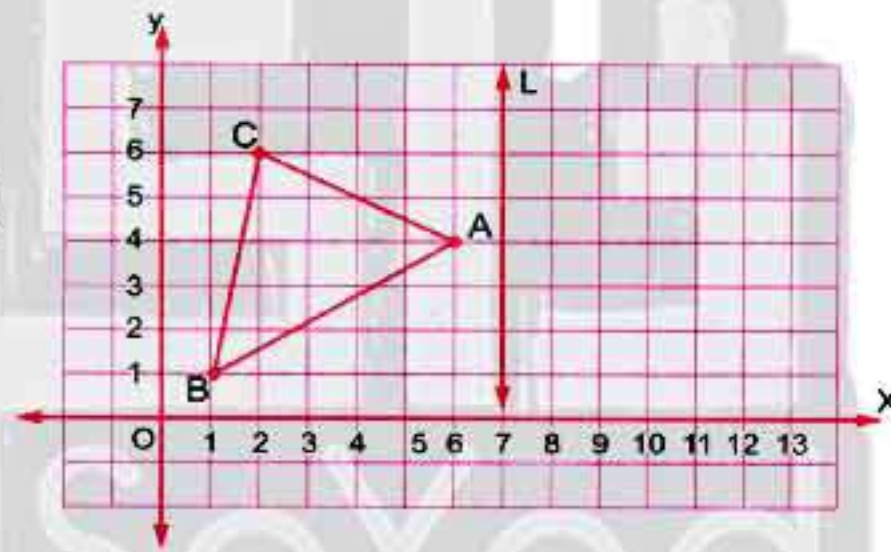

[b] Solve the following equation :  
 $2x + 9 = 21$  ,  $x \in \mathbb{N}$

5 [a] A triangle whose area is  $120 \text{ cm}^2$  and its height is 5 cm.  
 Find the length of its base.

[b] The following table shows the frequency distribution of the  
 number of work hours of 50 workers :

Set	10 –	20 –	30 –	40 –	Total
Frequency	12	8	16	14	50

Draw the frequency polygon which represent these data



## Final Examinations

## Additional question

Choose the correct answer :

- (1)  $(5 - 9) \dots\dots\dots \mathbb{N}$  ( $\in$  or  $\subset$  or  $\notin$  or  $\not\subset$ )
- (2) The next number in the pattern 1 , 3 , 9 , 27 is .....
- (30 or 33 or 81 or 36)
- (3)  $(4 \times \dots\dots\dots) \times 78 = 7800$  (5 or 25 or 50 or 125)
- (4)  $(7 \times 2) \times 5 = \dots\dots\dots \times (2 \times 5)$  (2 or 5 or 7 or 14)

## 20 Kafr El-Sheikh Governorate

El-Borg Educational Directorate  
Directorate of Maths

Answer the following questions :

## 1 Complete :

- [a] The circumference of the circle =  $\pi \times \dots\dots\dots$
- [b] If  $x + 2 = 5$  , then  $x = \dots\dots\dots$
- [c] If  $y = x + 5$  , then the constant is .....
- [d] Adding 5 to twice the number  $x$  is .....

## 2 Choose the correct answer :

- [a] If  $3x = 15$  ,  $x \in \mathbb{N}$  , then  $x = \dots\dots\dots$  ( 12 or 5 or  $\frac{1}{5}$  or  $\frac{1}{3}$  )
- [b] If A (2 , 3) , B (2 , 7) , then the midpoint of  $\overline{AB}$  is .....
- (( 10 , 4) or (2 , 5) or (2 , 10) or (0 , 9) )
- [c] The area of a rhombus of diagonals 10 cm. and 20 cm. = .....
- ( 200 or 30 or 100 or 400 )
- [d] The sum of the two numbers  $x$  and  $y$  is 10 , then  $x = \dots\dots\dots$
- ( 10 or  $10 + x$  or  $10 - x$  or  $10 - y$  )

3 [a] If the number  $x$  exceeds twice the number  $y$  by 9 write the mathematical relation between  $x$  and  $y$ 

- [b] Solve the equation :  $2x - 1 = 3$  in  $\mathbb{N}$

## 4 [a] Find the area of a triangle whose base length is 12 cm. and height is 5 cm.

- [b] Find the circumference of a circle if its diameter is 14 cm. ( $\pi = \frac{22}{7}$ )



- 5 [a] Draw the image of the  $\triangle ABC$  by reflection in the straight line L.

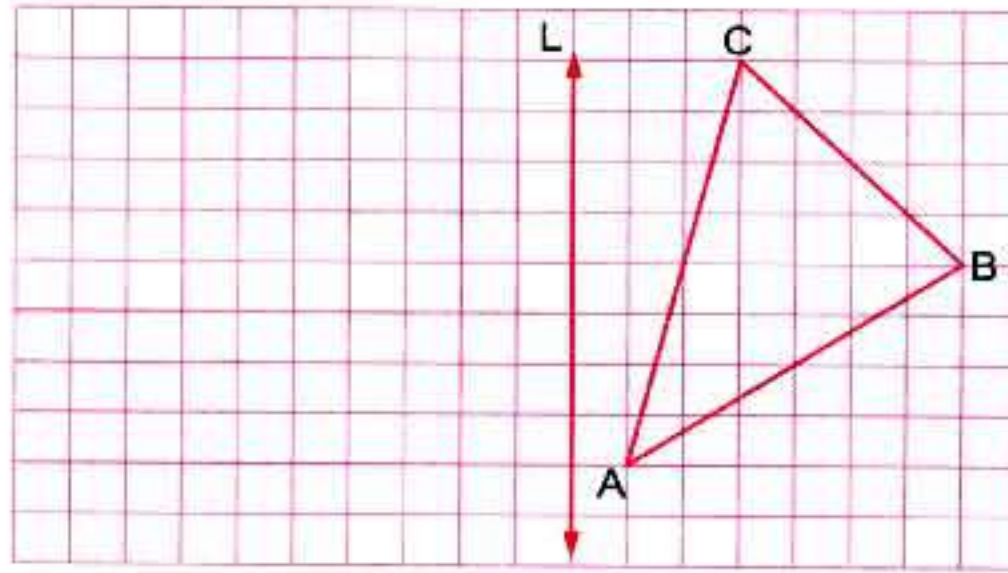

- [b] The following table shows the marks of 50 pupils in math test in one month :

Sets	10 –	20 –	30 –	40 –	Sum
Frequency	10	12	18	10	50

Represent these data by frequency polygon.

### Additional question

- [a] List , then represent the following set on the number line :

$$X = \{x : x \in \mathbb{N}, 2 \leq x < 6\}$$

- [b] Use the distributive property to get the product of :  $18 \times 99$

## 21 El-Beheira Governorate

Rashid Educational Zone  
Maths supervision



Answer the following questions :

- 1 Complete the following :

- [a] Twice a number  $x$  is .....
- [b] The area of the rhombus =  $\frac{1}{2} \times$  the product of .....
- [c] If the area of square is  $8 \text{ cm}^2$  , then its diagonal length = ..... cm.
- [d] The perimeter of equilateral triangle whose side is  $x$  = .....

- 2 Choose the correct answer :

- [a] If  $x + 5 = 11$  , then  $x =$  ..... ( 5 or 6 or 7 or 8 )
- [b] A circumference of a circle is 22 cm. , then its diameter length = ..... cm. where  $\pi = \frac{22}{7}$  ( 3.5 or 7 or 8 or 11 )
- [c] The square has ..... axes of symmetry. ( 0 or 2 or 3 or 4 )



## Final Examinations

[d] A triangle whose area =  $120 \text{ cm}^2$ , and its height =  $10 \text{ cm}$ . , then its base length = ..... cm. ( 12 or 18 or 24 or 10 )

3 [a] Solve the equations in  $\mathbb{N}$ :

(1)  $x - 3 = 21$

(2)  $3y = 27$

[b] Which is larger in area ? a triangle with base  $8 \text{ cm}$ . and height  $7 \text{ cm}$ . or a parallelogram with base length  $6 \text{ cm}$ . and height  $5 \text{ cm}$ .

4 [a] If the diameter length of a bicycle's wheel is  $66 \text{ cm}$ . what is the covered distance if the wheel turns  $1000$  rounds ? where  $(\pi = 3.14)$

[b] In the coordinate plane , draw the triangle ABC where A  $(2, 1)$  , B  $(5, 1)$  and C  $(5, 5)$  , then draw the image of the triangle ABC by reflection in  $\overleftrightarrow{BC}$

5 [a] The lengths of the diagonals of a rhombus are  $30 \text{ cm}$ . and  $20 \text{ cm}$ . Calculate its area.

[b] Represent the following data by a frequency polygon.

Sets	3 -	6 -	9 -	12 -	15 -	Total
Frequency	4	7	10	6	3	30

## Additional question

Complete :

[a] The additive neutral element in  $\mathbb{N}$  is .....

[b]  $47 \times (36 + 64) = 47 \times \dots = \dots$

[c] The set of even numbers – the set of odd numbers = .....

[d] If  $5 + 0 = 0 + 5 = 5$  , then it is called ..... property.

## 22 El-Fayoum Governorate

Directorate of Education  
Supervisors of Mathematics



Answer the following questions :

1 Choose the correct answer :

[a] If we subtract 5 from  $x$  , we get .....

(  $5x$  or  $5 - x$  or  $x - 5$  or  $x + 5$  )

[b] The area of the triangle in which the length of its base  $10 \text{ cm}$ . and its height  $6 \text{ cm}$ . is .....  $\text{cm}^2$  ( 30 or 60 or 16 or 15 )



[c]  $34000 = \dots\dots\dots$  thousands. (  $34000$  or  $3400$  or  $340$  or  $34$  )

[d] The shown transformation is called  $\dots\dots\dots$   $b | d$   
( reflection or rotation or translation )

**2** Complete each of the following :

[a]  $5x = 35$  ,  $x \in \mathbb{N}$  , then  $x = \dots\dots\dots$

[b] The number of axes of symmetry of a square =  $\dots\dots\dots$

[c] The smallest odd prime number is  $\dots\dots\dots$

[d] If the perimeter of a square is 32 cm. , then its side =  $\dots\dots\dots$  cm.

**3** [a] Solve the following equations such that  $x \in \mathbb{N}$ :

(1)  $x - 4 = 1$

(2)  $3x + 8 = 29$

[b] A parallelogram of area  $36 \text{ cm}^2$  , and the length of its base is 4 cm. , find the corresponding height of its base.

**4** [a] Which is smaller in area ?

A rhombus whose diagonals lengths is 8 cm. and 5 cm. or a rectangle whose width is 5 cm. and length is 6 cm.

[b] A circle of radius 14 cm. , find its circumference. ( $\pi = \frac{22}{7}$ )

**5** [a] On a coordinate plane , draw the figure ABCD where A (1 , 1) , B (4 , 1) , C (4 , 3) , D (1 , 3) then complete :

(1) The length of AB =  $\dots\dots\dots$  unit.

(2) The name of the figure ABCD is  $\dots\dots\dots$

[b] Draw the frequency polygon which represent the following table of data :

Sets	10 -	20 -	30 -	40 -	50 -	Total
Frequency	3	4	6	4	3	20

### Additional question

Complete using ( $\in, \notin, \subset$  or  $\not\subset$ ):

[a]  $\frac{0}{3} \dots\dots\dots \mathbb{N}$

[b]  $\left\{ \frac{1}{3}, 1, 2 \right\} \dots\dots\dots \mathbb{N}$

[c] The set of even numbers  $\dots\dots\dots$  The set natural numbers.

[d]  $\{2, 3, 0, 4\} \dots\dots\dots \mathbb{N}$



## Final Examinations

## 23 Beni Suef Governorate

Directorate of Education  
Directorate of Official Lang Schools

Answer the following questions :

## 1 Choose the correct answer :

[a]  $x + 5 = 20$  ,  $x \in \mathbb{N}$  , then  $x = \dots\dots\dots$  ( 4 or 6 or 15 or 25 )[b] The number of altitudes of the triangle is  $\dots\dots\dots$   
( 0 or 1 or 2 or 3 )[c] The number of axes of symmetry of the rhombus =  $\dots\dots\dots$   
( 1 or 2 or 3 or 4 )[d] If the sum of two numbers  $x$  and  $y$  is 20 , then  $y = \dots\dots\dots$   
(  $20 + x$  or  $20 - x$  or  $x - 20$  or  $y + 20$  )

## 2 Complete the following :

[a] Area of rectangle =  $\dots\dots\dots \times \dots\dots\dots$ [b] The length of diagonal of square is 12 cm. , then its area =  $\dots\dots\dots$  cm<sup>2</sup>[c] Area of parallelogram =  $\dots\dots\dots \times \dots\dots\dots$ [d] The opposite transformation is  $\dots\dots\dots$  3 [a] Solve the equations , where  $x \in \mathbb{N}$  :

(1)  $2x + 7 = 19$

(2)  $x - 8 = 18$

[b] Find the circumference of a circle with a radius 14 cm. ( $\pi = \frac{22}{7}$ )

## 4 In a coordinate plane determine the points A (2 , 2) , B (4 , 2) , C (4 , 8) and D (2 , 8) , then :

[a] Draw ABCD

[b] Draw the image ABCD by reflection on  $\overleftrightarrow{BC}$ 

## 5 [a] Which is greater in area ? a rhombus whose diagonals are 6 cm. and 8 cm. or a square whose diagonal is 8 cm.

[b] The following data represents the marks in Arabic test for students in one classroom :

Sets	10 -	20 -	30 -	40 -	Total
Frequency	8	12	16	14	50

Draw the histogram for this distribution.



## Additional question

Using the properties of addition and multiplication in  $\mathbb{N}$ , find :

[a]  $48 + 37 + 52 + 63$

[b]  $125 \times 17 \times 8$

## 24 El-Menia Governorate

Governmental Language Schools  
General Supervisor of mathematics



Answer the following questions :

## 1 Complete :

[a]  $3x = 15$ , then  $x = \dots\dots\dots$

[b] The square whose diagonal 8 cm. , its area  $\dots\dots\dots$   $\text{cm}^2$

[c] The number of axes of symmetry of the rhombus =  $\dots\dots\dots$

[d] The perimeter of a rectangle is 20 cm. if its length is  $x$ , then its width is  $\dots\dots\dots$

## 2 Choose the correct answer :

[a] The diameter length of a circle is 14 cm. , then its radius =  $\dots\dots\dots$  cm.  
( 14 or 7 or 28 or 3.5 )

[b] The length of the base of the triangle is 8 cm. and its height is 5 cm. , then the area =  $\dots\dots\dots$   $\text{cm}^2$   
( 8 or 9 or 20 or 40 )

[c] The perimeter of the equilateral triangle whose side length  $L$  cm. is  $\dots\dots\dots$  cm.  
(  $L + 3$  or  $\frac{1}{3}L$  or  $L - 3$  or  $3L$  )

[d]  $x + 8 = 15$  ,  $x \in \mathbb{N}$  , then  $x = \dots\dots\dots$  ( 3 or 7 or 6 or 5 )

## 3 [a] Solve :

(1)  $y - 3 = 9$  where  $y \in \mathbb{N}$

(2)  $2x + 9 = 21$  where  $x \in \mathbb{N}$

[b] Find the circumference of a circle with diameter length 14 cm. ( $\pi = \frac{22}{7}$ )

## 4 [a] From the opposite graph , complete :

A (  $\dots\dots\dots$  ,  $\dots\dots\dots$  )

B (  $\dots\dots\dots$  ,  $\dots\dots\dots$  )

C (  $\dots\dots\dots$  ,  $\dots\dots\dots$  )

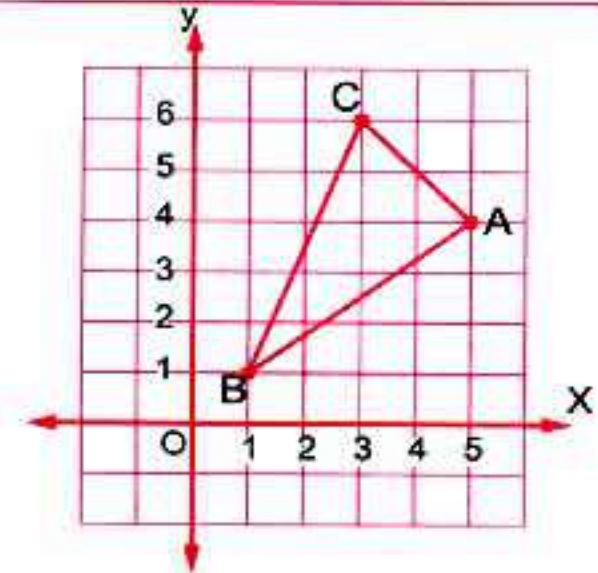



## Final Examinations

[b] Find the area of rhombus whose side length 12 cm. and its height 10 cm.

5 [a] Translate the statement into an equation :  
If 9 is subtracted from a number , then the result is 23

[b] Represent the following data by histogram :

Sets	10 –	20 –	30 –	40 –	Total
Frequency	3	7	5	6	21

## Additional question

Complete :

[a] If A , B , C are natural numbers , then  $(A \times B) \times C = A \times (B \times C)$  called ..... property.

[b]  $91 \times (73 + 27) = 91 \times \dots = \dots$

[c] The smallest natural number is .....

[d] The additive neutral element in  $\mathbb{N}$  is .....

## 25 Assiut Governorate

Assiut Educational Zone  
Al-Tahreer Language School



Answer the following questions :

1 Choose the correct answer :

[a] If  $x + 3 = 5$  ,  $x \in \mathbb{N}$  , then  $x = \dots$  ( 1 or 2 or 3 or 4 )

[b] The area of rhombus whose diagonals length are 6 cm. and 8 cm. is .....  $\text{cm}^2$  ( 48 or 12 or 24 or 40 )

[c] If the longest chord in a circle is 7 cm. then the circumference of the circle is ..... cm. where  $\pi = \frac{22}{7}$  ( 3.7 or 7 or 22 or 44 )

[d] The difference between two numbers is 5 , the smaller one is y the then greater number is ..... ( 5y or 5-y or y-5 or y+5 )

2 Complete :

[a] Area of parallelogram = .....  $\times$  .....

[b] The number of axes of symmetry of the rectangle = .....



- [c] The rhombus whose area is  $36 \text{ cm}^2$  and the length of one of its diagonals is  $8 \text{ cm}$ . then the length of the other diagonal = ..... cm.
- [d] Shorouk saved  $x$  pounds , her father gave her 10 pounds then she has .....

3 [a] Solve the equation :  $2x + 9 = 21$  ,  $x \in \mathbb{N}$

[b] In the opposite figure :

There is a window which has the form of a square , whose side length is  $70 \text{ cm}$ . , and above it , there is a semicircle.

- (1) Calculate the perimeter of the window.
- (2) If the area of the semicircle is  $3850 \text{ cm}^2$  , find the area of the window.

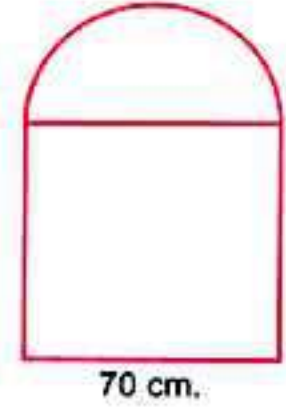

- 4 [a] Which is greater in area ? a square whose diagonal length is  $10 \text{ cm}$ . or a right angled triangle whose legs are  $8 \text{ cm}$ . and  $6 \text{ cm}$ .

[b] Find the number which if added to 3 , the sum will be 9

- 5 [a] In the cartesian co-ordinates plane , determine the points A (2 , 2) , B (4 , 2) , C (4 , 8) and D (2 , 8) If  $\overline{BC}$  is the axis of reflection of the figure ABCD , determine the image of the figure ABCD

[b] The following table shows the frequency distribution of the number of work hours of 50 workers. Graph these data using the frequency polygon :

Sets	2 -	4 -	6 -	8 -	10 -	Total
Frequency	8	9	15	16	2	50

### Additional question

Choose the correct answer :

- [a]  $\frac{5}{7}$  .....  $\mathbb{N}$  (  $\in$  or  $\notin$  or  $\subset$  or  $\not\subset$  )
- [b] If  $X = \{a : a \in \mathbb{N} , 4 < a < 5\}$  , then  $X =$  .....  
(  $\{4\}$  or  $\{5\}$  or  $\{4, 5\}$  or  $\emptyset$  )
- [c] The set of even numbers (E)  $\cap$  the set of prime numbers (P) = .....  
( P or  $\{0\}$  or  $\mathbb{N}$  or  $\{2\}$  )
- [d] The sum of two natural numbers .....  $\mathbb{N}$  (  $\in$  or  $\notin$  or  $\subset$  or  $\not\subset$  )



## Final Examinations

## 26 Souhag Governorate

Directorate of Education  
Directorate of Official Language Schools

Answer the following questions :

## 1 Choose the correct answer :

- [a] The area of rhombus whose diagonals lengths are 6 cm. and 8 cm. is .....  $\text{cm}^2$  ( 48 or 12 or 24 or 40 )
- [b] If the longest chord in a circle is 7 cm. , then the circumference of the circle is ..... cm. where  $(\pi = \frac{22}{7})$  ( 3.5 or 7 or 22 or 44 )
- [c] The number of axes of symmetry of rhombus equals ..... ( zero or 1 or 2 or 4 )
- [d] Twice the number  $x$  subtracted 7 from it = ..... (  $7 - x$  or  $2x - 7$  or  $7x + 2$  or  $14x$  )

## 2 Complete the following :

- [a] The perimeter of square whose side length is 10 = ..... cm.
- [b] Area of the triangle =  $\frac{1}{2}$  the length of its base  $\times$  .....
- [c] The side length of a square is 5 cm. , then its area = .....  $\text{cm}^2$
- [d] The number of symmetry axes of an equilateral triangle = .....

## 3 [a] Solve each of the following equation :

(1)  $2x + 8 = 14$

(2)  $x - 7 = 25$

- [b] Find the area of a triangle whose base length is 5 cm. and the corresponding height is 6 cm.

## 4 [a] In the opposite figure :

ABCD is a parallelogram  
where  $AD = 12 \text{ cm.}$  ,  $CD = 6 \text{ cm.}$   
,  $ED = 5 \text{ cm.}$  and  $\overline{ED} \perp \overline{BC}$

Find the area of the parallelogram.

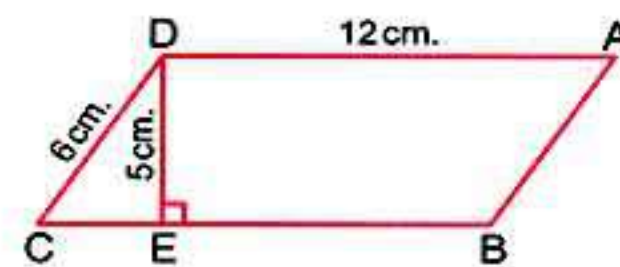

- [b] Graph the figure ABCD where  $A(2, 7)$  ,  $B(3, 4)$  ,  $C(8, 4)$   
and  $D(7, 7)$  What is the name of the figure ABCD ?



- 5 The following table shows the frequency distribution of the number of work hours of 50 workers :

Sets	4 –	6 –	8 –	10 –	Total
Frequency	12	8	16	14	50

Draw the frequency polygon which represent these data.

### Additional question

- [a] Write in the list method the set :  $X = \{x : x \in \mathbb{N}, 3 \leq x \leq 8\}$  , then represent its element on the number line.
- [b] Use the properties of addition to find the result of the following :  
 $82 + 75 + 18$

27

Aswan Governorate

Aswan Educational Directorate  
Edfu Language School

Answer the following questions :

- 1 Choose the correct answer from those given :

- [a] The number of axes of symmetry of the rhombus is .....  
 ( 1 or zero or 2 or 4 )
- [b] If  $3x = 15$  , then  $x =$  .....  
 ( 5 or 12 or  $\frac{1}{5}$  or  $\frac{1}{3}$  )
- [c]  $\frac{1}{2}$    $\frac{1}{8}$  .....  
 ( < or = or > )
- [d] The circle in which the length of the greatest chord is 14 cm.  
 , its circumference = ..... (  $\pi = \frac{22}{7}$  ) ( 3.5 or 14 or 22 or 44 )

- 2 Complete each of the following :

- [a] Area of square =  $\frac{1}{2} \times$  .....  $\times$  .....
- [b] The measure of a right angle = .....
- [c] If we add 5 to three times of the number  $y$  , then we get the number .....
- [d] The square whose diagonal length is 10 cm. , its area is .....  $\text{cm}^2$



## Final Examinations

- 3 [a] ABC is a triangle , its base length is 18 cm. and its height is 6 cm. , then find its area.
- [b] Which is greater in area ? a rhombus the lengths of its diagonals are 8 cm. , 6 cm. , or the parallelogram in which the length of its base is 10 cm. and the corresponding height is 5 cm.

- 4 [a] Solve the following equation :  $x + 3 = 12$

- [b] In a coordinate plane, draw  $\Delta ABC$  where A (2 , 3) , B (5 , 3) and C (5 , 7) , then draw the image of  $\Delta ABC$  by reflection across  $\overline{BC}$

- 5 [a] The parallelogram whose area is  $36 \text{ cm}^2$  and the length of a side of it is 9 cm. , then find the corresponding height to this side.

- [b] The following table shows the frequency distribution of the number of work hours of 50 workers :

Sets	4 –	6 –	8 –	10 –	Total
Frequency	12	8	16	14	50

Draw the frequency histogram and frequency polygon which represent these data.

## Additional question

Complete :

- [a] The set of natural numbers more than 5 is .....
- [b] 2 , 7 , 12 , 17 , ..... , ..... (in the same pattern)
- [c] If  $A \times 60 + A \times 4 = 3 \times 64$  , then  $A = \dots\dots\dots$
- [d] The multiplicative neutral element in  $\mathbb{N}$  is .....

## 28 South Sinai Governorate

Dahab Educational Directorate



Answer the following questions :

- 1 Choose the correct answer :

- [a] The perimeter of square with side length  $x = \dots\dots\dots$

(  $4x$  or  $x + 4$  or  $\frac{x}{4}$  or  $x - 4$  )

- [b] 6 added to the number  $y$  is .....

(  $6y$  or  $y + 6$  or  $y - 6$  or  $\frac{y}{6}$  )



[c] If  $x + 8 = 15$ , then  $x = \dots\dots\dots$  (3 or 7 or 6 or 5)

[d] The number of axes of symmetry of rhombus =  $\dots\dots\dots$   
(zero or 1 or 2 or 4)

**2 Complete the following :**

[a] The area of parallelogram =  $\dots\dots\dots \times \dots\dots\dots$

[b] The area of triangle whose base length 8 cm. and height 5 cm.  
=  $\dots\dots\dots \text{cm}^2$

[c] The place value of the digit 3 in the number 6.135 is  $\dots\dots\dots$

[d] If  $x$  is odd number then  $x + 2$  is  $\dots\dots\dots$  number.

**3 [a] Find the circumference of a circle with diameter length 7 cm. ( $\pi = \frac{22}{7}$ )**

[b] Complete : If  $15 \times 34 = (5 + 10) \times x$ , then  $x = \dots\dots\dots$

[c] Solve the equation :  $3x + 7 = 19$

**4 [a] In the Cartesian coordinate plane determine the following points**

A (6 , 6) , B (6 , 2) , C (1 , 2) and D (1 , 6)

What's the name of the figure ?

[b] Find the area of rhombus whose diagonals lengths are 6 cm. and 8 cm.

**5 The following table shows the marks of 35 students in math exam :**

Sets	10 –	20 –	30 –	40 –	total
Frequency	8	12	10	5	35

Represent these data by frequency polygon.

**Additional question**

Using the properties of commutation , distribution and associative in  $\mathbb{N}$ , find the value of each of the following :

(1)  $8 \times 184 \times 125$

(2)  $28 + 59 + 72 + 41$

(3)  $137 \times 36 - 37 \times 36$



## Final Examinations

## 29 Red Sea Governorate

Quosair Educational Administration



Answer the following questions :

## 1 Complete :

- [a] The number of axes of symmetry of the rhombus = .....
- [b] The perimeter of an equilateral triangle whose side length is  $L$  = .....
- [c] If  $4 + x = 15$  , then  $x$  = .....
- [d] The circle whose diameter length is 10 cm. , its circumference = ..... cm. (where  $\pi = 3.14$ )

## 2 Choose the correct answer :

- [a] The triangle whose base length is 5 cm. , and the corresponding height of it is 6 cm. , its area = .....  $\text{cm}^2$  ( 30 or 15 or 25 or 36 )
- [b] If  $3x = 15$  , then  $x$  = ..... ( 5 or 12 or  $\frac{1}{5}$  or  $\frac{1}{3}$  )
- [c] Twice the number  $x$  subtracted 3 from it = ..... (  $x - 3$  or  $2x + 3$  or  $2x - 3$  or  $3 - 2x$  )
- [d] The square whose diagonal length is 8 cm. its area = .....  $\text{cm}^2$  ( 64 or 32 or 16 or 8 )

## 3 [a] Find the area of a rhombus in which the length of its diagonals are 8 cm. and 6 cm.

[b] Solve the following equation :  $x + 3 = 13$ 

## 4 [a] Find the area of a parallelogram in which the length of the base = 10 cm. , and its height = 5 cm.

[b] In the coordinate plane draw the triangle ABC where A (2 , 5) , B (5 , 2) and C (5 , 8) , then draw the image of the triangle ABC by reflection across  $\overleftrightarrow{BC}$ 

## 5 The following frequency table shows the marks of 35 students in the exam :

Sets	10 –	20 –	30 –	40 –	Total
Frequency	8	12	10	5	35

Draw the frequency polygon which represents these data.



## Additional question

Choose the correct answer :

- [a]  $\{3, \frac{15}{4}\}$  .....  $\mathbb{N}$  ( $\in$  or  $\notin$  or  $\subset$  or  $\not\subset$ )
- [b] The set of odd numbers ..... the set of natural numbers.  
( $\in$  or  $\notin$  or  $\subset$  or  $\not\subset$ )
- [c] If  $x$  is an odd number , then  $x + 2$  is ..... number  
(odd or even or prime)
- [d] If  $7 \times 15 = 15 \times a$  , then  $a =$  .....  
(15 or 7 or 10 or 5)

## 30 Matrouh Governorate

Matrouh Educational Directorate  
Maths Inspection

Answer the following questions :

## 1 Complete the following :

- [a] If a radius of circle is  $(r)$  , then the circumference of a circle =  $\pi \times$  .....
- [b] The sum of two number is 21 and one of them is  $x$  , then the other is .....
- [c] If  $7 \times 15 = 15 \times x$  , then  $x =$  .....
- [d] Area of parallelogram = .....
- [e] If the diagonal length of a square is 10 cm. , then its area = .....  $\text{cm}^2$

## 2 Choose the correct answer between brackets :

- [a] If the diagonals lengths of a rhombus 10 cm. , 12 cm. , then its area = .....  $\text{cm}^2$  (120 or 60 or 24 or 32)
- [b] Subtract 7 from double number  $x$  .....  
( $x - 7$  or  $2x - 7$  or  $7x + 2$  or  $14x$ )
- [c] Area of triangle in which the length of its base is 12 cm. and its height is 5 cm. = .....  $\text{cm}^2$  (30 or 60 or 17 or 34)
- [d] The diameter of circle = ..... (r or  $3r$  or  $4r$  or  $2r$ )
- [e] If  $x + 8 = 15$  , then  $x =$  ..... (3 or 7 or 6 or 5)

## 3 [a] Find the area of a parallelogram in which length of its base is 15 cm. and its corresponding height is 4 cm.



## Final Examinations

[b] Find the value of  $x$  which make the following equation correct :

(1)  $x - 3 = 9$

(2)  $2x + 5 = 17$

4 In the coordinate plane :

[a] Determine the position of the points A (8 , 5) , B (8 , 2) , C (5 , 2) , D (5 , 7)

[b] Draw line segments  $\overline{AB}$  ,  $\overline{AD}$  ,  $\overline{CD}$  ,  $\overline{BC}$

[c] If  $\overline{CD}$  is a reflection axis of shape ABCD, find its image using the suitable symbole.

5 The following table shows marks of 40 students in math exam :

Sets	10 –	20 –	30 –	40 –	50 –	sum
Frequency	5	7	12	9	7	40

Represent these data by histogram and frequency polygon.

## Additional question

Use the properties of operations of natural numbers to find the result :

(1)  $8 \times 47 \times 125$

(2)  $56 \times 42 + 56 \times 58$



## Final Examinations

## Some Schools' Examinations From Different Governorates

1

Cairo



El-Nozha Directorate of Education  
Our Lady of Perpetual Succour School

Answer the following questions :

1 Complete the following :

- (a) If  $X = \{x : x \in \mathbb{N}, 2 \leq x \leq 3\}$ , then  $X = \{\dots\dots\dots\}$
- (b) The square whose area is  $72 \text{ cm}^2$ , the length of its diagonal =  $\dots\dots\dots$  cm.
- (c) 1, 4, 8, 13,  $\dots\dots\dots$  (in the same pattern)
- (d) If  $945 = (x \times 100) + 45$ , then  $x = \dots\dots\dots$

2 Choose the correct answer :

- (a) If E is the set of even number then  $E \dots\dots\dots \mathbb{N}$   
( $\in$  or  $\notin$  or  $\subset$  or  $\not\subset$ )
- (b) The multiplicative neutral element in  $\mathbb{N}$  is  $\dots\dots\dots$   
(zero or 1 or 2 or 4)
- (c) The area of a triangle whose base length 5 cm. and the corresponding height 6 cm. is  $\dots\dots\dots \text{ cm}^2$  (30 or 15 or 25 or 36)
- (d) If the longest chord in a circle is 7 cm. then the circumference of the circle is  $\dots\dots\dots$  cm. where. ( $\pi = \frac{22}{7}$ ) (3.5 or 7 or 22 or 44)

3 (a) Use the properties of operations to find the result of :

(1)  $38 + 47 + 62 + 53$  (2)  $8 \times 37 \times 125$

- (b) Draw  $\Delta ABC$  where A (2, 5), B (5, 2), C (5, 8)

Then find its image by reflection on  $\overleftrightarrow{BC}$

4 (a) Which is greater in area :

A rhombus in which the lengths of its diagonals are 8 cm. and 6 cm. or a parallelogram in which the length of its base is 10 cm. and the corresponding height is 5 cm. then calculate the difference between them.

(b) Solve each of the following equations :

(1)  $\frac{1}{6}x - 3 = 2$

(2)  $3x + 7 = 19$





- 5 (a) The opposite figure shows a football playground :  
Find its perimeter ( $\pi = \frac{22}{7}$ )

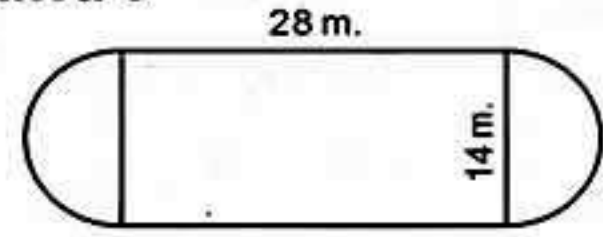

- (b) Represent the following distribution by histogram :

Sets	10 -	20 -	30 -	40 -	50 -	Total
Frequency	6	5	12	8	9	40

2

Cairo



Nasr City Directorate  
Talaee El-Kamal Islamic Language School

Answer the following questions :

- 1 Choose the correct answer :

- (a) Subtract 3 from twice the number  $x = \dots\dots\dots$   
(  $x - 3$  or  $2x + 3$  or  $2x - 3$  )
- (b) The number of axes of symmetry of the rhombus =  $\dots\dots\dots$   
( 0 or 1 or 2 or 4 )
- (c) If the set of even number is E , then  $E \dots\dots\dots \mathbb{N}$   
(  $\in$  or  $\notin$  or  $\subset$  or  $\not\subset$  )
- (d) The diameter length of circle whose circumference 88 cm. =  $\dots\dots\dots$  ( $\pi = \frac{22}{7}$ )  
( 28 or 14 or 7 or 21 )

- 2 Complete the following :

- (a) The set of prime numbers which are less than 17 is  $\dots\dots\dots$
- (b) If  $x + 8 = 15$  ,  $x \in \mathbb{N}$  , then  $x = \dots\dots\dots$
- (c) The area of a triangle whose base length 5 cm. and the corresponding height 6 cm. is  $\dots\dots\dots$  cm<sup>2</sup>
- (d) The multiplicative neutral element in  $\mathbb{N}$  is  $\dots\dots\dots$

- 3 (a) Use the distribution property to find the value of :

(1)  $519 \times 99$

(2)  $316 \times 1001$

- (b) Which is greater in area :

A rhombus in which the lengths of its diagonals are 6 cm. and 8 cm. or a parallelogram in which the length of its base is 10 cm. and the corresponding height is 5 cm. , then calculate the difference between them.



## Final Examinations

- 4 (a) Calculate the perimeter of the opposite figure where  $(\pi = \frac{22}{7})$

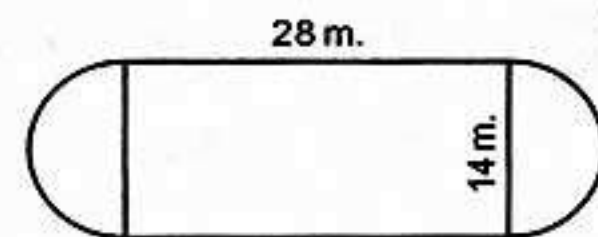

- (b) In the cartesian co-ordinate plane draw the figure ABCD where A (8 , 5) , B (8 , 2) , C (5 , 2) , D (5 , 7). If CD is the axis of reflection of the figure ABCD Draw the image of the figure ABCD.

- 5 (a) Solve each of the following equations :

(1)  $\frac{1}{6}x - 3 = 2$

(2)  $2x + 9 = 21$

- (b) The table below shows the frequency distribution of the number of work hours of 50 workers.

Sets	4 -	6 -	8 -	10 -	Total
Frequency	12	8	16	14	50

Draw the frequency polygon which represents these data.

3

Cairo



El-Khalifa & Mokattam Educational Zone  
Sama Language School

Answer the following questions :

- 1 Complete the following :

- (a) If : A (2 , 3) and B (2 , 7) , then the midpoint of  $\overline{AB}$  is ( ..... , ..... )  
 (b) The additive neutral element in  $\mathbb{N}$  is .....  
 (c) If  $x + 8 = 15$  ,  $x \in \mathbb{N}$  , then  $x =$  .....  
 (d)  $74(73 + 27) = 74 \times \dots = \dots$

- 2 Choose the correct answer :

- (a)  $3 + 9 \dots \mathbb{N}$  ( $\in$  or  $\notin$  or  $\subset$  or  $\not\subset$ )  
 (b) If :  $X = \{x : x \in \mathbb{N} , 2 \leq x \leq 3\}$  , then  $X = \{\dots\}$   
 ( $\{3, 2\}$  or  $\{3\}$  or  $\{2\}$  or  $\emptyset$ )  
 (c) A rhombus in which the length of its diagonals are 10 cm. and 12 cm. , its area = .....  $\text{cm}^2$  (120 or 60 or 24 or 32)  
 (d) The opposite figure :  represents .....  
 (reflection or translation or rotation)





3 (a) (1) Evaluate using the commutative and associative properties :

$$8 \times 137 \times 125$$

(2) Use the distributive property to find the value of :  $36 \times 1001$

(b) Solve each of the following equations :

(1)  $x + 7 = 19, x \in \mathbb{N}$

(2)  $3x = 21, x \in \mathbb{N}$

4 (a) Which is greater in area :

A square whose diagonal length is 10 cm. or a triangle whose base length is 12 cm. and its corresponding height is 6 cm.

(b) In the 2-dimensional coordinate plane locate the points :

A (5, 0), B (9, 0), C (9, 4), D (5, 4), name the shape ABCD then find its image by reflection in  $\overline{DC}$

5 (a) Find the perimeter of the opposite figure

$$\left(\pi = \frac{22}{7}\right)$$

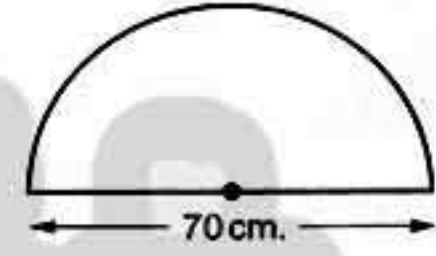

(b) The following frequency table shows the marks of 35 students in the mathematics exam. Graph these data using the frequency polygon.

Sets	5 -	10 -	15 -	20 -	25 -	Total
Frequency	5	9	11	6	4	35

4

Cairo



El-Salam Educational Zone  
Anwar El-Sadat E.L.S.

Answer the following questions :

1 Choose the correct answer :

(a) The number of axes of symmetry of the rhombus = .....

(0 or 1 or 2 or 4)

(b) If :  $x + 2 = 5, x \in \mathbb{N}$ , then  $x = \dots\dots\dots$  (2 or 3 or 5 or 4)

(c)  $\mathbb{N} - \mathbb{E} = \dots\dots\dots$  ( $\mathbb{N}$  or 0 or E or P)

(d)  $39 \times 115 = 39 \times 100 + 39 \times \dots\dots\dots$  (115 or 10 or 5 or 15)

2 Complete the following :

(a) 1000, 100, 10, ....., ....., (In the same pattern)

(b) If :  $(4, 7) = (2a, b - 1)$ , then  $a = \dots\dots\dots$ ,  $b = \dots\dots\dots$



## Final Examinations

- (c) If we subtract 7 from twice the number  $x = \dots\dots\dots$
- (d) The height of parallelogram with area  $40 \text{ cm}^2$  and base length 5 cm. is  $\dots\dots\dots$

3 (a) Calculate the perimeter of the figure

$$\left(\pi = \frac{22}{7}\right)$$

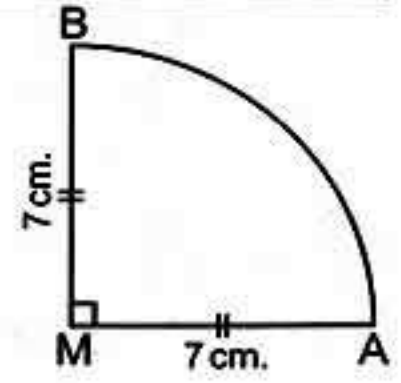

(b) Use operations properties in  $\mathbb{N}$  to find :

$$25 \times 781 \times 4$$

4 (a) Solve the equation :  $3x + 8 = 29$  ,  $x \in \mathbb{N}$

(b) Find the area of the square whose perimeter is 20 cm.

5 (a) In a coordinate plane represent the points A (2 , 3) , B (3 , 5) , C (5 , 3)  
Find the image of  $\triangle ABC$  by reflection in  $\overleftrightarrow{AC}$

(b) Represent by frequency polygon :

Sets	10 -	20 -	30 -	40 -	50 -
Frequency	6	5	12	8	9

5

Cairo



Helwan Educational Department  
Elias Language School for Boys

Answer the following questions :

1 Complete the following :

- (a)  $18 \times 15 = 15 \times \dots\dots\dots$  (  $\dots\dots\dots$  property)
- (b) If "A" is an odd number , then "A + 2" is  $\dots\dots\dots$  number.
- (c) If  $3x = 45$  , then  $x = \dots\dots\dots$
- (d) 20 , 19 , 17 , 14 ,  $\dots\dots\dots$  (in the same pattern)

2 Choose the correct answer :

- (a) A square of diagonal length 12 cm. , its area =  $\dots\dots\dots \text{ cm}^2$   
( 120 or 144 or 72 or 36 )
- (b) The multiplicative neutral element in  $\mathbb{N}$  is  $\dots\dots\dots$   
( 2 or 1 or zero or 10 )





## Final Examinations

- (c) The smallest even counting number is .....  
( zero or 1 or 2 or 4 )
- (d) Ali is "b" years old , then his age after 3 years is .....  
( b + 3 or b - 3 or 3b or 3 - b )

3 (a) Solve in  $\mathbb{N}$  : (1)  $x - 3 = 7$       (2)  $2x + 9 = 21$

- (b) Which is greater in area : A parallelogram of base length 8 cm. and height 6 cm. , or a triangle of base length 10 cm. and height 8 cm.

- 4 (a) Find perimeter of the following figure

$$\left(\pi = \frac{22}{7}\right)$$

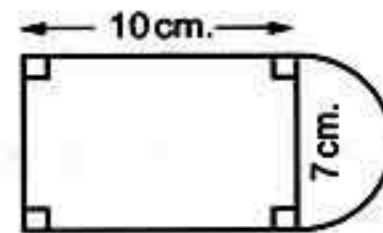

- (b) In the coordinate plane , draw the triangle XYZ , in which X (2 , 4) , Y (5 , 2) and Z (5 , 6) , then find its image by reflection in  $\overleftrightarrow{YZ}$

- 5 (a) Use properties in  $\mathbb{N}$  to Find :

(1)  $25 \times 19 \times 4$

(2)  $12 \times 105$  (using distribution property)

- (b) Represent the following data by the frequency polygon :

Sets	2 -	4 -	6 -	8 -
Frequency	8	9	5	11

6

Cairo



Rod El-Farag Directorate  
El-Sayeda Aisha Language School

Answer the following questions :

- 1 Choose the correct answer :

- (a) The sum of two natural number .....  $\mathbb{N}$  (  $\subset$  or  $\not\subset$  or  $\in$  or  $\notin$  )
- (b) If  $3x = 15$  ,  $x \in \mathbb{N}$  , then  $x =$  ..... ( 5 or 12 or  $\frac{1}{5}$  or  $\frac{1}{3}$  )
- (c) The circumference of a circle with diameter 21 cm. is ..... (  $\pi = \frac{22}{7}$  )  
( 128 or 32 or 66 or 1024 )
- (d) The number of axes of symmetry of the rhombus = .....  
( 1 or 2 or 3 or 4 )

- 2 Complete the following :

- (a) The additive neutral element in  $\mathbb{N}$  is = .....
- (b) The multiplicative neutral element in the natural numbers plus 99 .....



## Final Examinations

- (c) Double the number  $x$  subtracted 7 from it equal .....
- (d) The length of the diagonal of a square is 12 cm. then its area = ..... cm<sup>2</sup>

3 (a) Using the properties of commutation , distribution and associative , find the value of each : (1)  $8 \times 137 \times 125$  (2)  $28 + 59 + 72$

(b) Solve the equation :  $2x + 9 = 21$   $x \in \mathbb{N}$

4 (a) The opposite figure ABCD is a parallelogram ,  
AB = 10 cm. , DE = 12 cm. , DF = 8 cm. . Find

- (1) The area of parallelogram ABCD  
(2) Length of  $\overline{BC}$

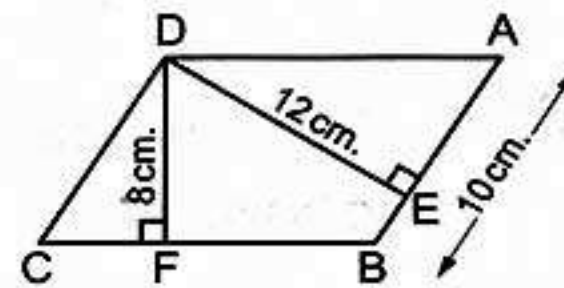

(b) In the cartesian co-ordinates plane determine the point A (2 , 2) , B (5 , 2) , C (5 , 8) , D (2 , 8). If  $\overline{BC}$  the axis of reflection of the figure ABCD , then determine the image of the figure ABCD

5 (a) ABCD is a rectangle of area 828 cm<sup>2</sup> ,  $E \in \overline{BC}$  ,  
AD = 23 cm. , BE = 35 cm. ,  
Find the area of  $\Delta DCE$

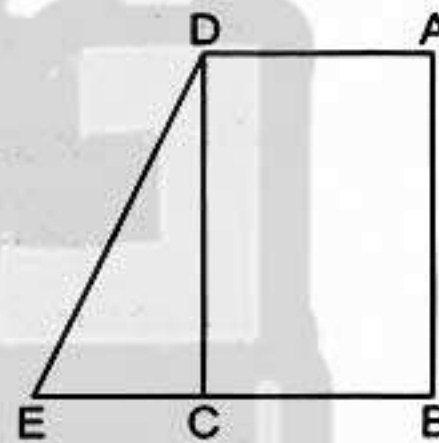

(b) The following table shows the marks of pupils in mathematics exam :

Sets	10 -	20 -	30 -	40 -	50 -	Total
Frequency	5	7	12	A	7	40

- (1) Find the value of A  
(2) Draw the frequency histogram which represent these data

7

Cairo

El-Mostakbal Educational Zone  
E.L.S.

Answer the following questions :

1 Choose the correct answer :

- (a)  $\{3.5\}$  .....  $\mathbb{N}$  ( $\in$  or  $\notin$  or  $\subset$  or  $\not\subset$ )
- (b) The sum of twice a number and 6 = .....  
( $x + 6$  or  $2x + 6$  or  $\frac{1}{2}(x + 6)$  or  $2(x + 6)$ )





## Final Examinations

- (c) The number of axes of symmetry of the square is ..... axes.  
(2 or 3 or 4 or 5)
- (d) The circumference of circle = .....  
( $\pi r$  or  $2\pi r$  or  $3\pi r$  or  $4\pi r$ )

## 2 Complete the following :

- (a) 26 , 20 , 15 , 11 , ..... , ..... (in the same pattern)
- (b)  $40 \times 115 = 39 \times 115 + 115 \times \dots\dots\dots$
- (c) If the area of a parallelogram is  $40 \text{ cm}^2$  and its base 8 cm. then its corresponding height equals ..... cm.
- (d) If  $x \times 5 = 15$  , then  $2x = \dots\dots\dots$

3 (a) By using properties of addition find :  $137 + 475 + 163 + 225$ 

- (b) Solve the following equation :  $2x - 7 = 5$  (Where  $x \in \mathbb{N}$ )

## 4 (a) Which is greater in area : A rhombus whose diagonal lengths are 12 cm. and 16 cm. or a square whose diagonal length is 14 cm. (show your steps).

- (b) On the coordinate plane draw the rectangle ABCD where A (1 , 1) , B (4 , 1) , C (4 , 5) and D (1 , 5) , then draw its image by reflection in  $\overline{BC}$

## 5 (a) Calculate the circumference of the circle whose diameter is 14 cm.

$$\left(\pi = \frac{22}{7}\right)$$

- (b) Represent the following distribution by frequency polygon :

Sets	5 -	15 -	25 -	35 -	45 -
Frequency	6	8	12	7	4

8

Cairo

New Cairo Directorate  
Experimental School

Answer the following questions :

## 1 Choose the correct answer :

- (a)  $\frac{2}{3} \dots\dots\dots \mathbb{N}$  ( $\in$  or  $\notin$  or  $\subset$  or  $\supset$ )
- (b) If :  $x + 1 = 6$  , then  $3x = \dots\dots\dots$  (5 or 7 or 15 or 51)
- (c) The diagonal length of a square is 6 cm. then its area is .....  $\text{cm}^2$   
(6 or 16 or 18 or 36)
- (d) The difference between twice a number  $x$  and 8 = .....  
( $8 - 2x$  or  $2x - 8$  or  $\frac{1}{2}x - 8$  or  $x - 8$ )



## Final Examinations

**2 Complete the following :**

- (a)  $3 \times (2 + 5) = 3 \times \dots + 3 \times \dots$   
 (b) The rhombus has ..... lines of symmetry.  
 (c) The smallest natural number is .....  
 (d) A circle of radius length 7 cm. then its circumference = ..... cm.

**3 (a) Use the properties of multiplication to calculate the value :**

$125 \times 19 \times 8$

- (b) If we subtracted 5 from three times a number the result will be 7  
 What's the number ?

**4 (a) Which is greater in area :** A triangle whose base length 18 cm. and height 12 cm. or a rhombus with diagonals lengths 24 cm. and 8 cm.

- (b) Draw the figure ABCD in the coordinate plane where A (1 , 2) , B (1 , 5) , C (4 , 5) , D (4 , 2).

(1) What is the name of the figure ABCD ?

(2) How many lines of symmetry of this figure ?

**5 (a) Find the radius length of circle whose circumference 154 cm.**

$(\pi = \frac{22}{7})$

- (b) The following table shows the marks of 50 pupils.

Sets	2 -	4 -	6 -	8 -	10 -
Frequency	10	9	12	8	11

Represent these data by histogram.

9

Giza



North Giza Educational Zone  
 Gawad Hossny School

Answer the following questions :

**1 Complete the following :**

- (a) The set of natural numbers less than 5 is .....  
 (b) If :  $7 \times 15 = 15 \times x$  , then  $x = \dots$   
 (c) Area of square =  $\frac{1}{2} \times \dots$   
 (d) The number of symmetry axes of an equilateral triangle is .....





**2 Choose the correct answer :**

- (a)  $(3 + 9) \dots \mathbb{N}$  ( $\in$  or  $\notin$  or  $\subset$  or  $\not\subset$ )  
 (b) The set of even numbers  $\dots$  the set of natural numbers.  
 ( $\in$  or  $\notin$  or  $\subset$  or  $\not\subset$ )  
 (c)  $x$  is an odd number , then  $x + 2$  is  $\dots$  number.  
 (even or odd or prime or otherwise)  
 (d) A rhombus of diagonals length 10 cm. and 12 cm. its area =  $\dots$  cm<sup>2</sup>.  
 (120 or 60 or 24 or 32)

**3 (a) Solve :  $2x + 9 = 21$  , where  $x \in \mathbb{N}$**

- (b) Using the properties of addition in  $\mathbb{N}$  to find :  $872 + 199 + 128 + 801$

**4 (a) From the opposite figure :**

Find the area of the parallelogram ABCD

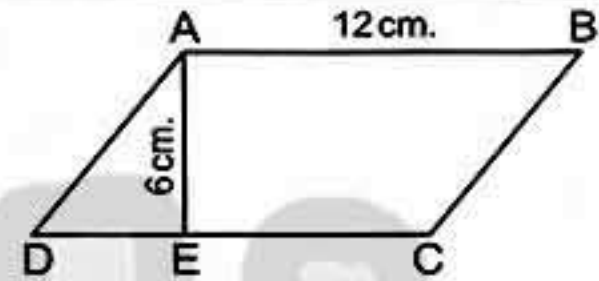

- (b) Graph the figure ABCD where A (2 , 7) , B (3 , 4) , C (8 , 4) and D (7 , 7)  
 What is the name of the figure ABCD ?

**5 (a) Find the circumference of the circle with diameter length 14 cm. ( $\pi = \frac{22}{7}$ )**

- (b) Represent the following distribution by frequency polygon :

Sets	10 –	20 –	30 –	40 –	50 –
Frequency	5	7	12	9	7

10

Giza



El-Doki Directorate  
 El-Orman Ex. Language School

Answer the following questions :

**1 Complete the following :**

- (a) The multiplicative identity element in  $\mathbb{N}$  is  $\dots$   
 (b) For any natural numbers  $a$  ,  $b$  and  $c$  where  $(a \times b) \times c = a \times (b \times c)$   
 this called  $\dots$  property.  
 (c) If the side length of a square is 10 cm. then its area  $\dots$   
 (d)  $23 \times (92 + 8) = 23 \times \dots = \dots$   
 (e) The area of a parallelogram whose base length is 8 cm. and height  
 2.5 cm. is  $\dots$  cm<sup>2</sup>



## Final Examinations

## 2 Choose the correct answer :

- (a) If the longest chord in a circle is 7 cm. , then the circumference of the circle is ..... cm. where  $(\pi = \frac{22}{7})$  ( 3.5 or 7 or 22 or 44 )
- (b) If :  $x + 7 = 19$  ,  $x \in \mathbb{N}$  then  $x =$  ..... ( 26 or 12 or 11 or 13 )
- (c) The area of a square whose diagonal length 6 cm. is .....  
( 18 cm<sup>2</sup> or 36 cm<sup>2</sup> or 12 cm. )
- (d) If :  $3x = 15$  ,  $x \in \mathbb{N}$  then  $x =$  ..... ( 5 or 12 or  $\frac{1}{5}$  or  $\frac{1}{3}$  )
- (e)  $(49 \div 8)$  .....  $\mathbb{N}$  ( $\in$  or  $\notin$  or  $\subset$  or  $\not\subset$  )

3 Use the properties to find the value of :  $28 + 78 + 782$ 

## 4 In the opposite figure :

The length of the diameter  $\overline{AB}$  of a semicircle is 14 cm.  
Find the distance around the figure  $(\pi = \frac{22}{7})$

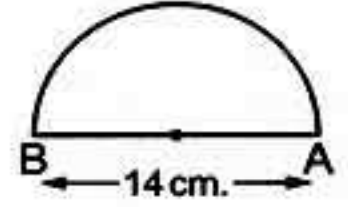

## 5 Represent these data by the frequency polygon :

Sets	5 -	10 -	15 -	20 -	25 -
Frequency	6	12	19	12	4

11

Giza

South Giza Educational Zone  
Mathematics Department

Answer the following questions :

## 1 Choose the correct answer :

- (a) The area of a rhombus whose diagonal lengths are 3 cm. and 4 cm. is ..... cm<sup>2</sup> ( 24 or 6 or 12 or 20 )
- (b) If :  $x + 8 = 12$  ,  $x \in \mathbb{N}$  then  $x =$  .....  
( 4 or 12 or 20 or 64 )
- (c) 1 , 4 , 9 , 16 , ..... (in the same pattern) ( 19 or 23 or 25 or 32 )
- (d)  $\frac{24}{4}$  .....  $\mathbb{N}$  ( $\in$  or  $\notin$  or  $\subset$  or  $\not\subset$  )

## 2 Complete the following :

- (a) The sum of two numbers is 35 , one of them is  $x$  then the other is .....
- (b) The least natural number is .....
- (c)  $53 + 48 + 47 = (53 + \dots) + 48 = \dots$
- (d) If  $x$  is an even number , then  $x + 3$  is ..... number.





- 3** (a) Solve the equation :  $2x + 9 = 21$  ,  $x \in \mathbb{N}$
- (b) Write by the listing method  $X = \{x : x \in \mathbb{N} , 3 < x < 8\}$  then represent its elements on the number line.
- 
- 4** (a) The diagonal length of a square is 6 cm. **Find its area.**
- (b) In a 2-dimensional coordinate plane. Draw the point A (2 , 2) , B (5 , 2) , C (5 , 8) and D (2 , 8)
- 
- 5** (a) Find the circumference of a circle. If its diameter is 7 cm. ( $\pi = \frac{22}{7}$ )
- (b) **The following table shows the frequency distribution of the number of work hours of 50 workers.**

Sets	4 -	6 -	8 -	10 -	Total
Frequency	12	8	16	14	50

Draw the frequency polygon which represents these data.

12

Giza

Abo El-Nomros Zone  
E.L.S.

Answer the following questions :

- 1** Choose the correct answer :

- (a)  $\frac{1}{5}$  .....  $\mathbb{N}$  ( $\in$  or  $\notin$  or  $\subset$  or  $\not\subset$ )
- (b) The opposite geometric transformation is .....  
(reflection or translation or rotation)
- (c) Youssef is  $x$  years old , then Youssef's age after 2 years will be .....  
( $2x$  or  $2-x$  or  $x+2$  or  $x-2$ )
- (d) The circumference of a circle with diameter length 42 cm. is ..... cm.  
Where ( $\pi = \frac{22}{7}$ ) ( $48$  or  $96$  or  $168$  or  $132$ )

- 2** Complete the following :

- (a) If :  $x + 4 = 10$  , then  $x =$  .....
- (b) 1 , 3 , 9 , ..... , ..... (in the same pattern)
- (c) The additive identity element is .....
- (d) The number of axes of symmetry of the rectangle = .....



## Final Examinations

3 (a) In the opposite figure :

ABCD is a parallelogram ,  
where  $AD = 12 \text{ cm}$  ,  $ED = 5 \text{ cm}$ .

Find the area of the parallelogram.

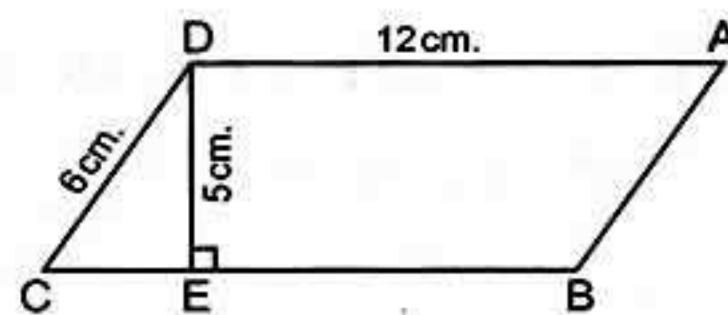

(b) Using the additive properties find the result :  $38 + 47 + 62 + 53$

4 Draw the triangle ABC where  $A(1, 3)$  ,  $B(4, 1)$  ,  $C(4, 7)$  ,  
then draw the image of the triangle ABC by reflection in  $\overleftrightarrow{BC}$

5 (a) Solve the equation :  $2x - 4 = 12$

(b) Represent the following data by the histogram :

Sets	5 -	7 -	9 -	11 -
Frequency	4	12	9	1

13

Alexandria



Central Educational Zone  
E.L.S.

Answer the following questions :

1 Choose the correct answer :

(a) If :  $x + 8 = 15$  ,  $x \in \mathbb{N}$  then  $x = \dots\dots\dots$  ( 23 or 7 or 6 or 5 )

(b) The square whose diagonal length is 8 cm. , its area =  $\dots\dots\dots \text{ cm}^2$   
( 64 or 32 or 16 or 8 )

(c) If :  $X = \{x : x \in \mathbb{N} , 3 \leq x < 5\}$  , then  $x \in \dots\dots\dots$   
( {4} or {3} or {3, 4} or {4, 5} )

(d)  $24 \times 10 = 24 \times 6 + 24 \times \dots\dots\dots$  ( 24 or 6 or 10 or 4 )

2 Complete the following :

(a) The set of prime numbers which are less than 17 is  $\dots\dots\dots$

(b) The perimeter of a rectangle is 16 cm. its width is 3 cm. then its area  
=  $\dots\dots\dots \text{ cm}^2$

(c) The sum of two numbers is 35 , one of them is  $x$  , then the other  
is  $\dots\dots\dots$

(d) A rhombus has two diagonals of length 6 cm. and 8 cm. , then its  
area =  $\dots\dots\dots \text{ cm}^2$





3 (a) Using the properties of commutation and association find the value of each of the following : (1)  $28 + 59 + 72$  (2)  $8 \times 137 \times 125$

(b) In the cartesian co-ordinate plane locate the points A (2 , 1) , B (5 , 1) , C (5 , 4) , then draw the image of  $\Delta ABC$  by reflection on  $\overleftrightarrow{BC}$

4 In the opposite figure :

ABCD is a parallelogram in which  $BC = 14$  cm. ,  
 $BE = 6$  cm. , M is the mid-point of  $\overline{AD}$ . Find :

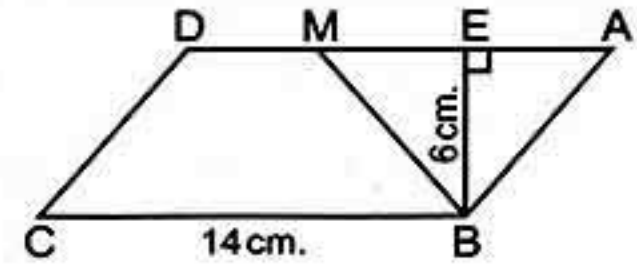

(a) The length of  $\overline{AD}$  and  $\overline{AM}$

(b) The area of parallelogram ABCD

(c) The area of  $\Delta ABM$

(d) The area of the figure MBCD

5 (a) Solve the following equation :  $2x + 9 = 21$  ,  $x \in \mathbb{N}$

(b) The following table shows the frequency distribution of the number of work hours of work.

Sets	20 –	30 –	40 –	50 –	60 –	Total
Frequency	6	10	14	7	3	40

Draw the frequency polygon which represent these data.

## 14 Alexandria



El-Montazah Educational Zone  
 Maths Supervision

Answer the following questions :

1 Complete the following :

(a)  $8 \times \dots = \dots \times 8 = 32$  (b) If :  $a \in \mathbb{N}$  , and  $b \in \mathbb{N}$  , then  $a \times b \dots \mathbb{N}$

(c) If :  $x \in \mathbb{N}$  ,  $2x - 3 = 7$  , then  $x = \dots$

(d) The area of a square whose side length is 8 cm. =  $\dots$  cm<sup>2</sup>

2 Choose the correct answer :

(a)  $3.5 \dots \mathbb{N}$

( $\in$  or  $\notin$  or  $\subset$  or  $\not\subset$ )

(b)  $(7 \times 2) \times 4 = \dots \times (2 \times 4)$

(3 or 5 or 7 or 9)

(c) If the diameter of a circle is 7 cm. , then the circumference =  $\dots$  cm.

( $\pi = \frac{22}{7}$ )

(11 or 22 or 44 or 66)

(d) The sum of two numbers 9 , one of them is  $x$  then the other is  $\dots$

( $x - 9$  or  $\frac{1}{9}x$  or  $9x$  or  $9 - x$ )



## Final Examinations

3 (a) Use the distributive property of multiplication over addition to complete :  $50 \times 8 + 50 \times 7 = 50 (\dots + \dots) = 50 \times \dots = \dots$

(b) The lengths of the diagonals of a rhombus are 30 cm. and 20 cm. Calculate its area.

4 (a) In the coordinate plane , draw the figure ABCD where A (3 , 1) , B (3 , 5) , C (7 , 5) and D (7 , 1) , **what is the name of the figure ABCD ?**

(b) Solve the following equations :

(1)  $3x - 5 = 16$  ,  $x \in \mathbb{N}$

(2)  $x + 2 = 2$  ,  $x \in \mathbb{N}$

5 Use the following table of data to draw the frequency polygon :

Sets	10 -	20 -	30 -	40 -	50 -
Frequency	6	10	12	8	6

15 El-Kalyoubia



Educational Zone  
Maths Supervision

Answer the following questions :

1 Choose the correct answer :

(a)  $(3 + 9) \dots \mathbb{N}$ .

( $\in$  or  $\notin$  or  $\subset$  or  $\not\subset$ )

(b) If :  $x - 2 = 5$  , then  $x = \dots$

(5 or 2 or 10 or 7)

(c) The area of a square whose diagonal length 10 cm. =  $\dots$  cm<sup>2</sup>

(100 or 50 or 60 or 80)

(d) The multiplicative identity in  $\mathbb{N}$  is  $\dots$

(1 or 0 or 2 or 3)

(e) The number of axes of symmetry of the rectangle =  $\dots$

(zero or 4 or 2 or 6)

2 Complete the following :

(a)  $32 + (59 + \dots) = (32 + \dots) + 68$

(b) 1 , 4 , 8 , 13 ,  $\dots$  (In the same pattern)

(c) If  $5x = 20$  , then  $x = \dots$

(d) The area of a triangle whose base length is 5 cm. and the corresponding height of it is 4 cm. =  $\dots$  cm<sup>2</sup>

(e) If  $(x , 5) = (3 , y)$  , then  $x = \dots$  ,  $y = \dots$

3 (a) Use the properties of addition to find the value of :  $34 + 57 + 66 + 43$

(b) Use the distributive property to find :  $27 \times 48 + 27 \times 52$





4 (a) Solve the equation :  $2x + 3 = 23$  ,  $x \in \mathbb{N}$

(b) In the opposite figure :

Find the area of a parallelogram ,  
in which  $AB = 8$  cm. ,  $DE = 5$  cm. ,  $\overline{DE} \perp \overline{AB}$

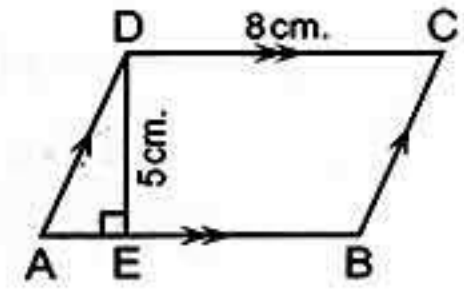

5 Use the following table of data to make a histogram :

Sets	10 -	20 -	30 -	40 -
Frequency	4	11	6	9

16 El-Sharkia



Directorate of Educational  
Mathematics Supervision For E.L.S.

Answer the following questions :

1 Complete the following :

- (a) Area of parallelogram of base 5 cm. and height 4 cm. is .....  $\text{cm}^2$   
 (b)  $0 \div 5 = \dots\dots\dots$  (c) 1 , 4 , 7 , 10 , ..... , ..... (in the same pattern)  
 (d) If  $y = 4$  , then  $3y = \dots\dots\dots$

2 Choose the correct answer :

- (a)  $(x + 12) \dots\dots\dots (x + 15)$  ,  $x \in \mathbb{N}$  ( $<$  or  $>$  or  $=$  or  $\geq$ )  
 (b) The opposite geometric transformation is .....  
 ( reflection. or translation. or rotation. )  
 (c) Area of square of diagonal 10 cm. = .....  
 ( 100 cm. or 100  $\text{cm}^2$  or 50 cm. or 50  $\text{cm}^2$  )  
 (d)  $(4 \times \dots\dots\dots) \times 78 = 7800$  ( 10 or 100 or 400 or 25 )

3 (a) In the 2-dimensions coordinate plane locate the points A (2 , 1) ,  
B (5 , 1) , C (5 , 4) , D (2 , 4) Draw the figure ABCD and name it.

(b) Find the midpoint of  $\overline{AB}$  if A (0 , 4) and B (8 , 4)

(c) Find the height of triangle if its area 50  $\text{cm}^2$  and its base length is 20 cm.

4 (a) Calculate the circumference of the circle which its diameter length 14 cm.

$$\left( \pi = \frac{22}{7} \right)$$

(b) Using the properties in  $\mathbb{N}$  to find the result of :

(1)  $79 + 36 + 21 + 64$

(2)  $4 \times 17 \times 25$



## Final Examinations

- 5 (a) Solve the equation :  $x + 3 = 8$  ,  $x \in \mathbb{N}$
- (b) Represent the following table by frequency polygon :

Sets	10 -	20 -	30 -	40 -	50 -
Frequency	8	10	11	9	6

17 El-Gharbia

El-Gharbia Educational Directorate  
Experimental Language Schools

Answer the following questions :

- 1 Choose the correct answer :

- (a)  $(5 - 7) \dots \mathbb{N}$ . ( $\in$  or  $\notin$  or  $\subset$  or  $\not\subset$ )
- (b) If :  $y(35 + 10) = 8 \times 45$  , then  $y = \dots$  , where  $y \in \mathbb{N}$   
(45 or 35 or 10 or 8)
- (c) The area of the rhombus whose diagonal lengths are 10 cm. and 15 cm. =  $\dots$  cm<sup>2</sup>. (150 or 75 or 50 or 25)
- (d) If 7 is subtracted from twice the number  $x$  , then the symbolic expression for this situation is  $\dots$   
( $7 - x$  or  $7 - 2x$  or  $2x - 7$  or  $3x - 7$ )

- 2 Complete the following :

- (a)  $52 + (61 + \dots) = (52 + 48) + \dots$
- (b) The perimeter of the square whose side length is  $k$  cm. =  $\dots$  cm.
- (c) The number of axes of symmetry of the isosceles trapezium =  $\dots$
- (d) The area of the square =  $\frac{1}{2} \dots \times \dots$

- 3 (a) Which is greater in area : The rhombus whose side length is 9 cm. and height = 8 cm. or the triangle whose base length is 14 cm. and height = 9 cm.

- (b) In the opposite figure :

ABCD is a parallelogram in which  
AD = 6 cm. , AE = 3 cm. , CD = 3.6 cm.

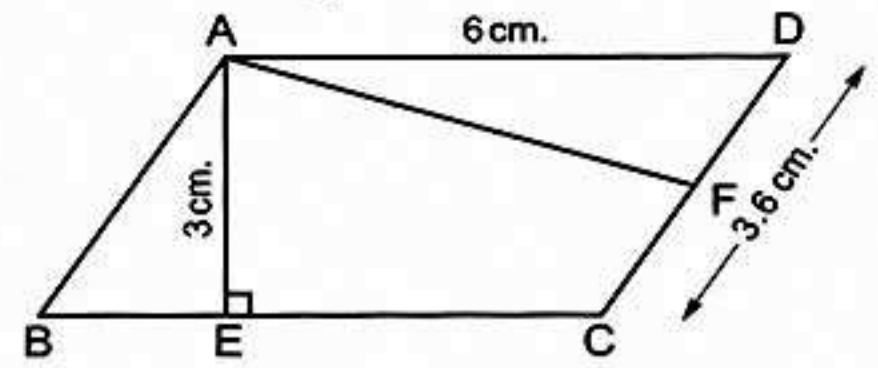
Find : (1) The area of the parallelogram ABCD (2) The length of  $\overline{AF}$ 

- 4 (a) On the coordinate plane , draw the triangle ABC where A (4 , 1) , B (4 , 6) and C (7 , 4) , then draw its image by reflection in
- $\overline{AB}$





(b) Use the properties of  $\mathbb{N}$  to find the result of :

(1)  $247 + 52 + 253 + 48$

(2)  $7 \times 98$

5 (a) Solve the following equations where  $x \in \mathbb{N}$  :

(1)  $2x - 1 = 7$

(2)  $x + 8 = 15$

(b) The following table shows the marks of 50 pupils in a Maths test :

Marks	10 -	20 -	30 -	40 -	Total
Frequency	10	12	18	10	50

Represent these data by a frequency polygon.

18 El-Dakahlia



Mathematics Supervision  
E.L.S.

Answer the following questions :

1 Complete the following :

(a) If  $x$  is the smallest odd prim number then  $x - 1 = \dots\dots\dots$

(b) If  $(x + 3) \times 17 = 17 \times 8$ , then  $x = \dots\dots\dots$

(c) The smallest prime number  $\times$  any prime number =  $\dots\dots\dots$  number.

(d) The circumference of a circle + its diameter =  $\dots\dots\dots$

2 Choose the correct answer :

(a) Twice the sum of the number  $x$  and three =  $\dots\dots\dots$

(  $2x + 3$  or  $2(x + 3)$  or  $5x$  or  $3x + 2$  )

(b) For any two natural numbers  $x$  and  $y$ , then  $(x - y)$  is possible only if  
 $x \dots\dots\dots y$  ( $>$  or  $\leq$  or  $\geq$  or  $<$ )

(c) If the area of a square =  $50 \text{ cm}^2$  then the length of its diagonal =  $\dots\dots\dots$  cm.  
(  $25$  or  $5$  or  $10$  or  $15$  )

(d) The number of symmetry axes of an equilateral triangle =  $\dots\dots\dots$   
(  $0$  or  $1$  or  $2$  or  $3$  )

3 In the opposite figure :

(a)  $\triangle BEF$  is the image of  $\triangle AEF$  by reflection across  $\dots\dots\dots$

(b) By reflection across  $\overleftrightarrow{FD}$  the image of  $\triangle FBD$  is  $\triangle \dots\dots\dots$

(c)  $\triangle FBA$  is congruent  $\triangle \dots\dots\dots$

(d) The area of  $\triangle FDB = \dots\dots\dots$  from the area of  $\triangle ABC$

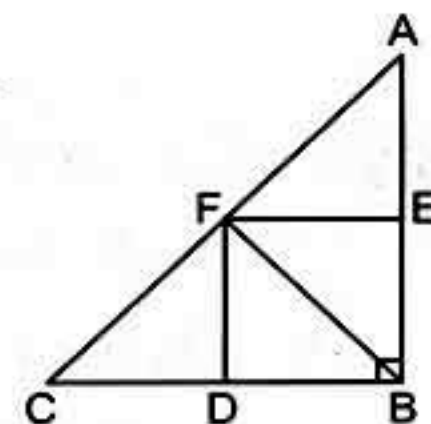



## Final Examinations

- 4 (a) Solve the equation :  $\frac{1}{2}x + 7 = 11$  , where  $x \in \mathbb{N}$   
 (b) By using properties calculate : (1)  $125 \times 328 \times 8$  (2)  $28 \times 18 - 28 \times 8$

- 5 (a) The area of parallelogram ABCD is  $96 \text{ cm}^2$ .  
 Calculate the area  
 of the figure EBCD

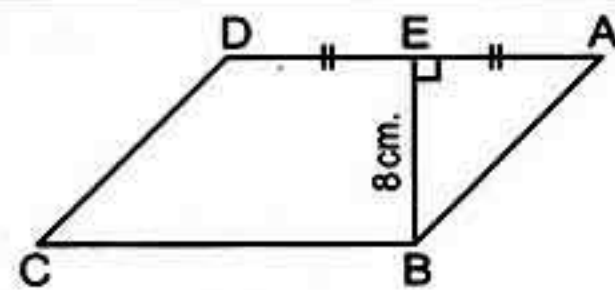

- (b) The following table represents the marks of 50 pupils on the math exam :

Sets	10 -	20 -	30 -	40 -	Total
Frequency	10	12	18	10	50

Draw the frequency polygon which represents the given data.

19

El-Ismailia



Directing Mathematics  
 El-Salam Language School

Answer the following questions :

- 1 Complete the following :

- (a) The smallest natural number is ..... (b) If  $2x = 6$  , then  $x = \dots\dots\dots$   
 (c) If the area of a parallelogram is  $36 \text{ cm}^2$  and the length of its base = 9 cm.  
 then the length of its height = ..... cm.  
 (d) If  $(x + 2) \times 15 = 5 \times 15$  , then  $x = \dots\dots\dots$

- 2 Choose the correct answer :

- (a) The age of a man now is  $x$  then his age after 5 years = .....  
 ( $x$  or  $x+5$  or  $x-5$  or  $2x$ )  
 (b)  $(5 - 7) \dots\dots\dots \mathbb{N}$  ( $\subset$  or  $\not\subset$  or  $\in$  or  $\notin$ )  
 (c) If the base length of a triangle is 6 cm .and its corresponding height  
 = 4 cm. then its area equal .....  $\text{cm}^2$  (10 or 24 or 12 or 2)  
 (d) The opposite transformation represents .....

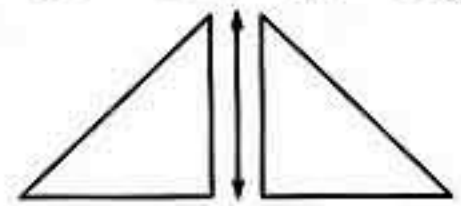

( flip or turn or slide )

- 3 (a) By using properties of addition and multiplication find :

(1)  $28 + 59 + 72 + 41$  (2)  $8 \times 137 \times 125$

- (b) Which is greater in area : A square with diagonal length 10 cm. or  
 a rhombus whose diagonals length 12 cm. and 10 cm.





4 (a) Solve the equations in  $\mathbb{N}$  :

(1)  $2x + 9 = 21$

(2)  $x - 3 = 5$

(b) In the two dimensions Cartesian coordinates draw  $\Delta ABC$  where A (1 , 3) , B (4 , 3) and C (4 , 6) , then find its image by reflection on  $\overleftrightarrow{BC}$

5 (a) Find the perimeter of the opposite figure :

$(\pi = \frac{22}{7})$

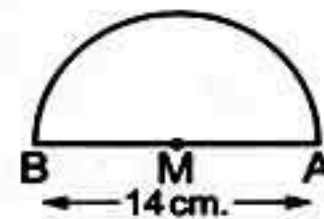

(b) The following table show the daily wages of workers in a company :

Sets	20 -	30 -	40 -	50 -	60 -	Total
Frequency	8	10	16	12	4	50

Draw the frequency polygon which represent these data.

20

Suez



Suez Educational Zone  
Directing Mathematics

Answer the following questions :

1 Choose the correct answer :

(a) If O is the set of odd number , then  $O \dots\dots\dots \mathbb{N}$

(  $\subset$  or  $\in$  or  $\not\subset$  or  $\notin$  )

(b) If x is an odd number , then  $x + 2$  is .....

( even. or odd. or prime or otherwise. )

(c) Twice the number x subtracted 7 from it = .....

(  $7 - x$  or  $2x - 7$  or  $7x + 2$  or  $14x$  )

(d) A rhombus of area  $30 \text{ cm}^2$  , the length of one of its diagonals is 6 cm.

, then the other diagonal = ..... cm. ( 4 or 6 or 8 or 10 )

2 Complete the following :

(a) The multiplicative neutral element in  $\mathbb{N}$  is .....

(b) The square whose area is  $72 \text{ cm}^2$  , the length of its diagonal = ..... cm.

(c) 1 , 4 , 8 , 13 , ..... (in the same pattern)

(d) The set of the natural number which are more than 4 and less than 5 is .....



## Final Examinations

3 (a) In the opposite figure :

ABCD is a parallelogram in which  $AB = 10$  cm. ,

$DE = 12$  cm. ,  $DF = 8$  cm. **Find :**

(1) The area of the parallelogram ABCD

(2) The length of  $\overline{BC}$

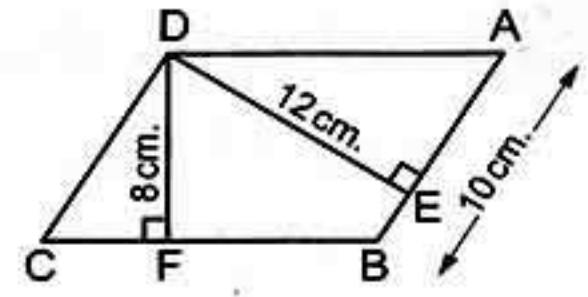

(b) Using the properties of commutation , distribution and association Find the value of each of the following :

(1)  $8 \times 137 \times 125 = \dots\dots\dots$

(2)  $28 + 59 + 72 = \dots\dots\dots$

4 (a) Solve the equation :  $2x + 9 = 21$  ,  $x \in \mathbb{N}$

(b) Complete : The diameter length of a circle whose circumference = 88 cm. equals  $\dots\dots\dots$  cm. ( $\pi = \frac{22}{7}$ )

5 (a) In the Cartesian coordinates plane determine the points A (2 , 2) , B (5 , 2) , C (5 , 8) , D (2 , 8) if  $\overline{BC}$  is the axis of reflection of the figure ABCD then determine the image of the figure ABCD

(b) The following table shows the marks of 35 pupils in mathematics exam in one of months where the full mark is 50

Sets	10 –	20 –	30 –	40 –	Total
Frequency	8	12	10	5	35

Draw the frequency polygon which represents these data.

21

Port Said



Education Directory  
Port Said Experimental Language School

Answer the following questions :

1 Complete the following :

(a)  $a + b = b + \dots\dots\dots$

(b) The smallest counting number is  $\dots\dots\dots$

(c) Area of triangle =  $\dots\dots\dots$

(d)  $3, 9, 27, \dots\dots\dots$

2 Choose the correct answer :

(a)  $1.58 \dots\dots\dots \mathbb{N}$  ( $\in$  or  $\notin$  or  $\subset$  or  $\not\subset$ )

(b)  $3x = 15$  , then  $x = \dots\dots\dots$  (3 or 4 or 5 or 12)

(c) The additive identity element is in  $\mathbb{N} \dots\dots\dots$  (1 or 2 or 3 or 4)

(d)  $E \cap O = \dots\dots\dots$  ( $\emptyset$  or E or O or P)





## Final Examinations

- 3 (a) Find the area of the following parallelogram.

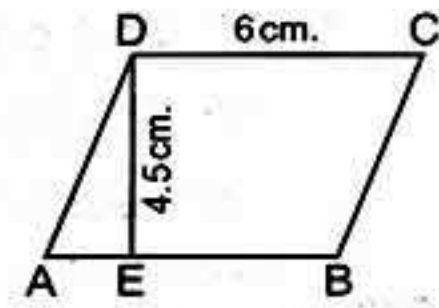

- (b) Solve the following equation :  $x + 3 = 18$   $x \in \mathbb{N}$

- 4 (a) Use the multiplicative properties to find :  $22 \times 102$

- (b) Use the additive properties to find :  $47 + 75 + 53 + 25$

- 5 (a) On a coordinate plane draw the triangle ABC in which A (4 , 5) , B (6 , 5) , C (4 , 2) , then draw its image by reflection on  $\overline{AB}$

(b)

Number of hours	5 -	10 -	15 -	20 -	25 -
Persons	6	10	12	10	4

Draw this data by a frequency polygon.

22

El-Beheira



Bandar Kafr El-Dawar Educational Zone  
Maths supervision

Answer the following questions :

- 1 Complete the following :

- (a) The additive neutral element in  $\mathbb{N}$  is ..... , while the multiplicative neutral element in  $\mathbb{N}$  is .....
- (b) The area of parallelogram whose base length 8 cm. and its height 3 cm. is .....  $\text{cm}^2$
- (c) 1 , 1 , 2 , 3 , 5 , ..... , ..... (in the same pattern)
- (d) The square has ..... lines of symmetry.

- 2 Choose the correct answer :

- (a) Twice the number  $x$  subtracted 3 from it = .....  
(  $x - 3$  or  $2x + 3$  or  $2x - 3$  or  $3 - 2x$  )
- (b) If :  $3x = 15$  ,  $x \in \mathbb{N}$  , then  $x =$  ..... ( 5 or 12 or  $\frac{1}{3}$  or  $\frac{1}{5}$  )
- (c) The area of a rhombus whose diagonals lengths are 6 cm. and 8 cm. is .....  $\text{cm}^2$   
( 48 or 12 or 40 or 24 )
- (d) The product of two natural numbers .....  $\mathbb{N}$ .  
(  $\in$  or  $\notin$  or  $\subset$  or  $\not\subset$  )

- 3 (a) Use the properties of operations in  $\mathbb{N}$  to find the result of :

(1)  $34 \times 99$

(2)  $45 + 36 + 55 + 64$



## Final Examinations

**b** In the coordinate plane represent the points :

A (2 , 3) , B (3 , 5) and C (5 , 3) , then find the image of  $\Delta ABC$  by reflection in  $\overleftrightarrow{AC}$

**4 a** Solve the following equations in  $\mathbb{N}$  :

(1)  $x + 3 = 12$

(2)  $2x - 9 = 21$

**b** Calculate the perimeter of the opposite figure :

Where  $(\pi = \frac{22}{7})$

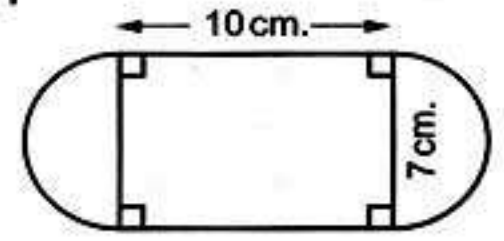

**5 a** Which is greater in area ?

A triangle whose base length is 12 cm. and its corresponding height = 8 cm. or a square of side length 7 cm.

**b** Represent these data using a histogram :

Sets	10 -	20 -	30 -	40 -	Total
Frequency	8	12	10	5	35

23

Beni Suef



Education Administration  
Experimental Language School

Answer the following questions :

**1** Complete the following :

- a** The smallest natural number is .....
- b** 3 , 9 , 27 , ..... , ..... (in the same pattern)
- c** The number of axes of symmetry of the square = .....
- d** If :  $15 - x = 9$  , then  $x$  .....

**2** Choose the correct answer :

- a** Double the number  $x$  subtracted 7 from it = .....  
(  $x - 7$  or  $2x - 7$  or  $7x + 2$  or  $14x$  )
- b** The area of a rhombus whose diagonals lengths are 4 cm. and 10 cm.  
= .....  $\text{cm}^2$  ( 40 or 80 or 20 or 10 )
- c** The circumference of a circle = .....  
(  $2\pi d$  or  $\pi r$  or  $4\pi r$  or  $2\pi r$  )
- d**  $\{2, 3, 0, 4\}$  .....  $\mathbb{N}$ . (  $\subset$  or  $\in$  or  $\not\subset$  or  $\notin$  )





## Final Examinations

3 (a) The length of the base of a triangle is 6 cm. and its height is 4 cm.  
**Find the area of this triangle.**

(b) In the orthogonal Cartesian coordinates locate the points  
A (3 , 5) , B (6 , 5) , C (3 , 2) then find the length of  $\overline{AC}$

4 (a) **By using the properties of operations in  $\mathbb{N}$ . Find the result of the following :  $4 \times 49 \times 25 = \dots\dots\dots$**

(b) **Solve the equation :  $3x + 8 = 29$**

5 (a) **Find the area of a parallelogram whose base length 10 cm. and height 3 cm.**

(b) **Use the following table of data to make the histogram :**

Sets	5 -	7 -	9 -	11 -
Frequency	4	12	9	8

24

El-Menia

El-Menia Educational Zone  
Mathematics Supervision

**Answer the following questions :**

1 **Complete the following :**

(a) If :  $x + 8 = 15$  ,  $x \in \mathbb{N}$  , then  $x = \dots\dots\dots$

(b) The square whose area is  $72 \text{ cm}^2$  , the length of its diagonal =  $\dots\dots\dots$

(c) The diameter length of the circle whose circumference is 88 cm.  
equals  $\dots\dots\dots$  cm.

(d)  $32 + (59 + \dots\dots\dots) = (32 + 68) + \dots\dots\dots$

2 **Choose the correct answer :**

(a) The number of axes of symmetry of the rhombus =  $\dots\dots\dots$

(zero or 1 or 2 or 4)

(b)  $(3 + 9) \dots\dots\dots \mathbb{N}$

( $\in$  or  $\notin$  or  $\subset$  or  $\not\subset$ )

(c) The triangle whose base length is 5 cm. , and the corresponding height is 6 cm. its area =  $\dots\dots\dots \text{ cm}^2$  (30 or 15 or 25 or 36)

(d) Twice the number  $x$  subtracted 3 from it =  $\dots\dots\dots$

( $x - 3$  or  $2x + 3$  or  $2x - 3$  or  $3 - 2x$ )



## Final Examinations

- 3 In the coordinate plane draw the triangle ABC where :  
A (1 , 2) , B (3 , 2) and C (3 , 4) then draw the image of the triangle ABC by reflection on  $\overline{BC}$

- 4 (a) Solve the equation :  $2x + 5 = 9$  ,  $x \in \mathbb{N}$

- (b) Calculate the perimeter of the opposite figure :

$$AM = 7 \text{ cm. } \left( \pi = \frac{22}{7} \right)$$

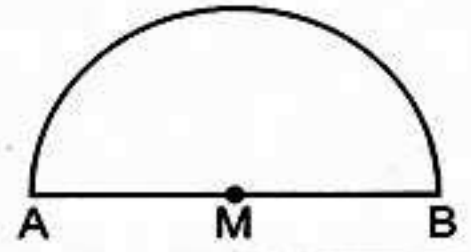

- 5 The following table shows the frequency distribution of the number of work hours of 50 workers :

Sets	4 -	6 -	8 -	10 -	Total
Frequency	12	8	16	14	50

Draw the frequency polygon which represents these data.

25

Assiut

Assiut Educational Directorate  
Experimental Language School

Answer the following questions :

- 1 Choose the correct answer :

- (a) The multiplication neutral element in  $\mathbb{N}$  is .....  
( 0 or 1 or 2 or 3 )
- (b) If :  $x - 7 = 19$  ,  $x \in \mathbb{N}$  , then  $x =$  .....  
( 12 or 24 or 26 or 30 )
- (c) If : a and  $b \in \mathbb{N}$  then  $a \times b \dots \mathbb{N}$  (  $\in$  or  $\notin$  or  $\subset$  or  $\not\subset$  )
- (d) The parallelogram has ..... lines of symmetry.  
( 0 or 1 or 2 or 3 )

- 2 Complete the following :

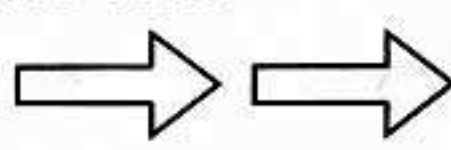
- (a) The sum of two numbers is 15 one of them is  $x$  , then the other = .....
- (b) The type of the opposite transformation is a ..... 
- (c) 1 , 4 , 8 , 13 , ..... , ..... (in the same pattern)
- (d) The rhombus whose area is  $36 \text{ cm}^2$ . and the length of one of its diagonals is 8 cm. , the length of the other diagonal = ..... cm.

- 3 (a) On 2-coordinate plane draw  $\Delta ABC$  where : A (2 , 1) , B (5 , 1) and C (5 , 5) , then draw the image of the triangle ABC by reflection in  $\overline{BC}$

- (b) Solve each of the following equations :

$$(1) 2x + 5 = 19$$

$$(2) \frac{1}{3}x + 8 = 10$$





**4 (a) Which is greater in area ?**

The triangle whose base length is 12 cm. and its corresponding height = 8 cm. or the parallelogram in which the length of the base = 10 cm. , and its corresponding height = 5 cm.

- (b) Using the properties of operations in  $\mathbb{N}$  to find the result of the following : (1)  $572 \times 99$  (2)  $113 + 419 + 87 + 181$

**5 (a) Find the perimeter of the opposite figure where**

$$MA = MB = 7 \text{ cm.}$$

$$\left(\pi = \frac{22}{7}\right)$$

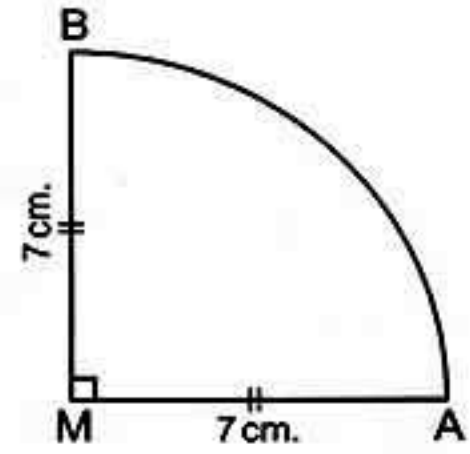

- (b) Represent the following distribution by frequency polygon :

Sets	5 -	7 -	9 -	11 -	13 -
Frequency	4	12	10	7	8

26

Souhag



Educational Directorate  
Mathematics Supervisor

Answer the following questions :

**1 Choose the correct answer :**

- (a) The sum of two natural numbers .....  $\mathbb{N}$  ( $\in$  or  $\notin$  or  $\subset$  or  $\not\subset$ )  
 (b) The area of a rhombus whose diagonals lengths are 6 cm. and 8 cm. is .....  $\text{cm}^2$  (48 or 20 or 24 or 40)  
 (c) If the longest chord in a circle is 7 cm. then the circumference of the circle is ..... cm. where  $\left(\pi = \frac{22}{7}\right)$  (3.5 or 7 or 22 or 44)  
 (d) If  $x + 7 = 19$ ,  $x \in \mathbb{N}$ , then  $x =$  ..... (26 or 12 or 11 or 13)

**2 Complete the following :**

- (a) The least natural number is .....  
 (b) The additive natural element in  $\mathbb{N}$  is ..... , while the multiplicative natural element in  $\mathbb{N}$  is .....  
 (c) Area of the triangle =  $\frac{1}{2}$  the length of its base  $\times$  .....  
 (d) The number of axes of symmetry of the rhombus equals .....



## Final Examinations

- 3 (a) Draw on the coordinates plane the triangle ABC where A (1 , 0) , B (2 , 2) and C (2 , 5) , then draw its image by reflection on  $\overline{BC}$
- (b) Use the commutative and associative properties in  $\mathbb{N}$  to calculate :  
 $872 + 199 + 128 + 801$
- 
- 4 (a) Zahraa saved 14 pounds she bought 3 notebooks for x pound for each the remainder with her was 8 pounds express there situations by an equation.
- (b) Find to the nearest hundredth the area of a parallelogram whose base length is 34.7 cm. and height 28.17 cm.
- (c) The diagonal length of a square 6 cm. **Find its area.**
- 
- 5 (a) In the orthogonal cartesian coordinates locate the points A (2 , 2) , B (5 , 2) , C (5 , 8) , D (2 , 8) then **complete** :
- (1) The length of  $\overline{AB}$  = ..... units. (2) The length of  $\overline{BC}$  = ..... units.
- (3) The figure ABCD is .....
- (4) The perimeter of the figure ABCD = ..... units.
- (b) **The following table shows the marks of 50 pupils in an exam of mathematics in one of months where the full mark is 50 marks. Draw the frequency histogram and the frequency polygon which represents these data :**

Sets	10 -	20 -	30 -	40 -	Total
Frequency	10	12	18	10	50

27

Aswan

Aswan Educational Directorate  
Experimental Language School

Answer the following questions :

- 1 Choose the correct answer :

- (a)  $\frac{5}{7}$  .....  $\mathbb{N}$  ( $\in$  or  $\notin$  or  $\subset$  or  $\not\subset$ )
- (b)  $10 \times 0 = \dots\dots\dots$  (100 or 10 or 0 or not possible)
- (c) If :  $2x = 6$  , then :  $x = \dots\dots\dots$  (2 or 3 or 4 or 6)
- (d) The circumference of the circle whose radius is 14 cm. equals ..... cm.  
 ( $\pi = \frac{22}{7}$ ) (14 or 22 or 44 or 88)





**2 Complete the following :**

- (a) If : A (0 , 4) and B (4 , 4) , then the coordinates of the midpoint of  $\overline{AB}$  is .....
- (b) The multiplicative identity element in  $\mathbb{N}$  is .....
- (c)  $(9 \times 4) \times 3 = \dots \times (3 \times 4)$
- (d) The area of the triangle =  $\frac{1}{2} \times \dots \times \dots$

**3 (a) Use the properties of addition to find the following :  $82 + 75 + 18$**

- (b) The lengths of the diagonals of a rhombus are 14 cm. and 10 cm.  
**Calculate its area.**

**4 (a) On a coordinate plane Draw the figure ABCD where A (1 , 1) , B (4 , 1) , C (4 , 3) , D (1 , 3) what is the name of the figure ABCD ?**

- (b) Find the height of the parallelogram with an area of  $48 \text{ cm}^2$  and its base is 8 cm.

**5 (a) Solve the equation :  $2x + 3 = 9$**

- (b) Use the following table of data to draw a histogram :

Number of hours	5 -	7 -	9 -	11 -
Frequency	4	12	9	5

28

South Sinai



South Sinai Educational Directorate  
Tur Sinai Educational Administration

Answer the following questions :

**1 Choose the correct answer :**

- (a)  $2 + 9 \dots \mathbb{N}$  ( $\in$  or  $\notin$  or  $\subset$  or  $\not\subset$ )
- (b) Twice the number  $x$  subtracted 3 from it .....  
( $x - 3$  or  $2x + 3$  or  $2x - 3$  or  $3 - 2x$ )
- (c) The square whose diagonal length is 8 cm. it's area = .....  $\text{cm}^2$   
(64 or 32 or 16 or 8)
- (d) The perimeter of a square whose side length  $L = \dots$   
( $2L$  or  $4L$  or  $3L$  or  $5L$ )

**2 Complete the following :**

- (a) The area of parallelogram = .....
- (b) If :  $x + 3 = 12$  , then  $x = \dots$



## Final Examinations

- (c) The next number in the pattern 5 , 35 , 65 , .....
- (d) 99 added to the neutral element of multiplication = .....

3 (a) Calculate the area of triangle whose base length 10 cm. and the corresponding height of it is 9 cm.

(b) Put "< , = or >":

(1)  $x + 18 \square x + 17$

(2)  $2239 \square 2229$

4 (a) Put ( $\checkmark$ ) for the correct statement and ( $\times$ ) for the wrong one :

(1)  $(5 - 8) \in \mathbb{N}$  ( )

(2) The additive neutral element in  $\mathbb{N}$  is one. ( )

(3) The value of  $x$  in the equation  $3x = 24$  is 8 ( )

(b) Find the circumference of a circle with diameter length 14 cm.

( $\pi = \frac{22}{7}$ )

5 The following table shows the marks of 40 pupils in mathematics exam.

Sets	10 -	20 -	30 -	40 -	50 -	Total
Frequency	5	7	12	9	7	40

Draw frequency histogram and the frequency polygon which represent these data

29

Red Sea



Safaga Educational Administration  
Safaga Experimental Language School

Answer the following questions :

1 Choose the correct answer :

- (a)  $25 \dots \mathbb{N}$  ( $\in$  or  $\notin$  or  $\subset$  or  $\not\subset$ )
- (b) The additive identity element in  $\mathbb{N}$  is ..... (0 or 1 or 2)
- (c) The circumference of a circle = ..... ( $\pi r$  or  $2\pi r$  or  $3\pi r$ )
- (d) If  $2x = 18$ , then  $x =$  ..... (6 or 8 or 9)
- (e)  $(12 \times 2) \div 2 =$  ..... (6 or 12 or 24)

2 Complete the following :

(a) If  $y - 7 = 5$ , then  $y =$  .....





## Final Examinations

- (b) The circumference of a circle with diameter 7 cm. = ..... cm.  
 (c) 1 , 3 , 6 , 10 , 15 , ..... (in the same sequence)  
 (d)  $(20 \times 50) \times 30 = \dots \times (50 \times 30)$   
 (e) A rhombus of diagonals length 12 cm. , and 10 cm. , its area = .....  $\text{cm}^2$

3 (a) **Graph the following figure** : A (1 , 2) , B (5 , 2) , C (3 , 7) and draw its line of symmetry.

(b) **Complete** : If  $2x + 3 = 15$  , then  $x = \dots$

4 (a) **Find the area of triangle with base 8 cm. and height 5 cm. ?**

(b) **Use the properties of multiplication to find** :  $4 \times 16 \times 25$

5 **Represent the following data by histogram** :

Sets	0 -	4 -	8 -	12 -
Frequency	8	12	3	7

30

Matrouh



Matrouh Educational Administration  
 Experimental Language School

**Answer the following questions :**

1 **Complete the following** :

- (a)  $2 \times (13 \times 5) = 2 \times (5 \times \dots)$   
 (b) The perimeter of a square whose side length is  $x = \dots$   
 (c) Area of the triangle = the length of its base  $x \dots$   
 (d) Dividing any natural number by ..... is not possible.

2 **Choose the correct answer** :

- (a) Add 6 to the number  $x$  , the symbolic expression is .....  
 ( $6 - x$  or  $6x$  or  $x - 6$  or  $x + 6$ )  
 (b)  $(8 - 10) \dots \mathbb{N}$  ( $\in$  or  $\notin$  or  $\subset$  or  $\not\subset$ )  
 (c) The area of a rhombus whose diagonals lengths are 6 cm. and 8 cm.  
 is .....  $\text{cm}^2$  ( $48$  or  $12$  or  $24$  or  $40$ )  
 (d) The next number in the pattern 5 , 35 , 65 is .....  
 ( $70$  or  $75$  or  $95$  or  $105$ )



## Final Examinations

3 (a) Use the distributive property to get the product of the following :  
 $18 \times 99$

(b) Translate this verbal statement into an equation :

A number if added to 17 the sum is 28

4 (a) Find the circumference of a circle with diameter length 14 cm.

$$\left(\pi = \frac{22}{7}\right)$$

(b) Solve the equation :  $x - 5 = 8$

5 The following table shows the marks of 50 pupils in an exam of mathematics in one of months where the full mark is 50 marks.

Sets	10 -	20 -	30 -	40 -	Total
Frequency	10	12	18	10	50

Draw the frequency polygon which represents these data.





Answers of Final examinations

Answers of models of school book

Model 1



1 (a) ∈ (b) 2 (c) 24

2 (a) (1) 20 (2) associative

(b) The area of the square  
 $= \frac{1}{2} \times 10 \times 10 = 50 \text{ cm}^2$   
 The area of triangle  $= \frac{1}{2} \times 8 \times 15 = 60 \text{ cm}^2$   
 The area of triangle is greater.

3 The equation is :  $2x + 10 = 24$   
 $2x + 10 = 24 \quad 2x = 24 - 10$   
 $2x = 14 \quad x = 14 \div 2 \quad x = 7$

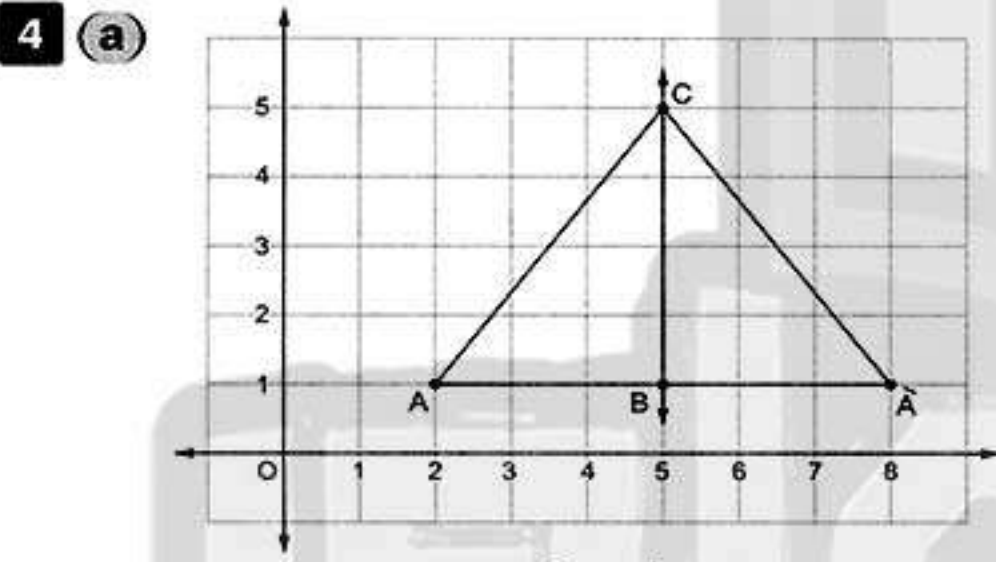

The area of  $\triangle ABC = \frac{1}{2} \times 6 \times 4 = 12$  units area

(b) The area of the parallelogram  
 $= 12 \times 5 = 60 \text{ cm}^2$   
 The height  $= 60 \div 6 = 10 \text{ cm}$ .

5 (a) (1) < (2) <

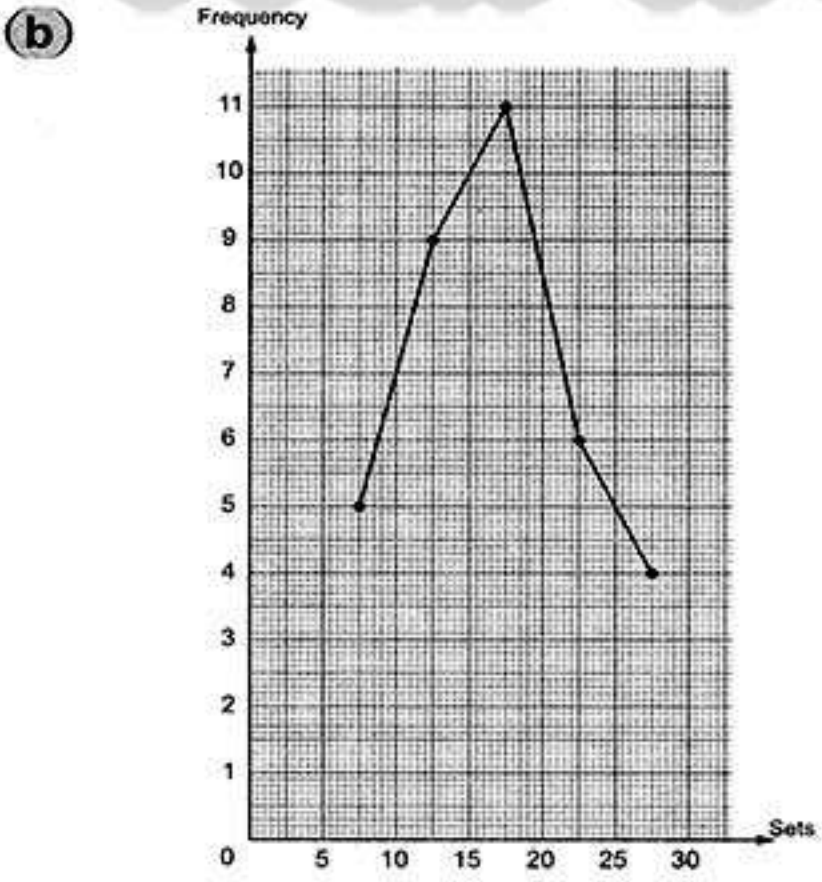

Model 2



1 (a) its diagonal , it self (b) ∈  
 (c) 100 , 2300 (d) {1 , 2 , 3 , 4}

2 (a) (1) 15 (2) ⊂ (3) 22

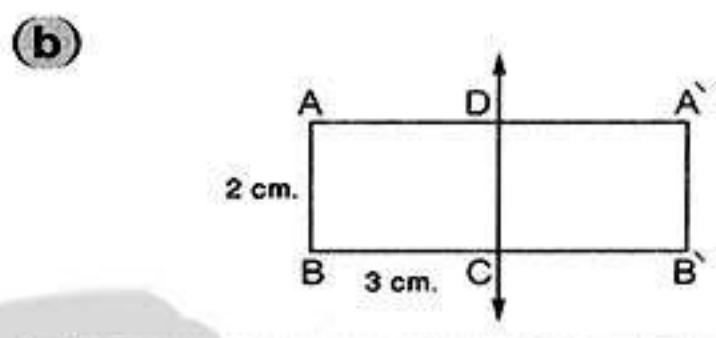

3 (a) (1) The area  $= \frac{1}{2} \times 10 \times 8 = 40 \text{ cm}^2$   
 (2)  $\triangle ADC$

(b) The equation is :  $20 - 3x = 5$   
 $20 - 3x = 5 \quad 20 - 5 = 3x$   
 $3x = 15 \quad x = 15 \div 3 \quad x = 5$

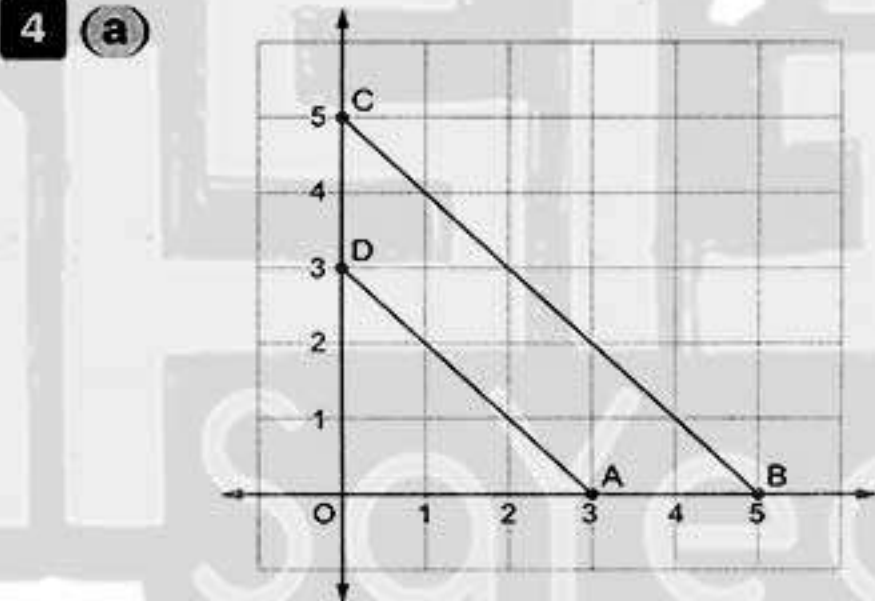

The area of  $\triangle OBC = \frac{1}{2} \times 5 \times 5 = 12\frac{1}{2}$  square units.

The area of  $\triangle OAD = \frac{1}{2} \times 3 \times 3 = 4\frac{1}{2}$  square units.

The area of figure ABCD  
 $= 12\frac{1}{2} - 4\frac{1}{2} = 8$  square units.

(b)  $872 + 199 + 128 + 801$   
 $= 872 + 128 + 199 + 801$   
 $= (872 + 128) + (199 + 801)$   
 $= 1000 + 1000 = 2000$



Answers of final examinations

5 (a) (1) The perimeter  
 $= (35 \times \frac{22}{7}) + 70 + 70 + 70 = 320 \text{ cm.}$

(2) The area of the square =  $70 \times 70$   
 $= 4900 \text{ cm}^2$

The area of the semicircle  
 $= 6825 - 4900 = 1925 \text{ cm}^2$

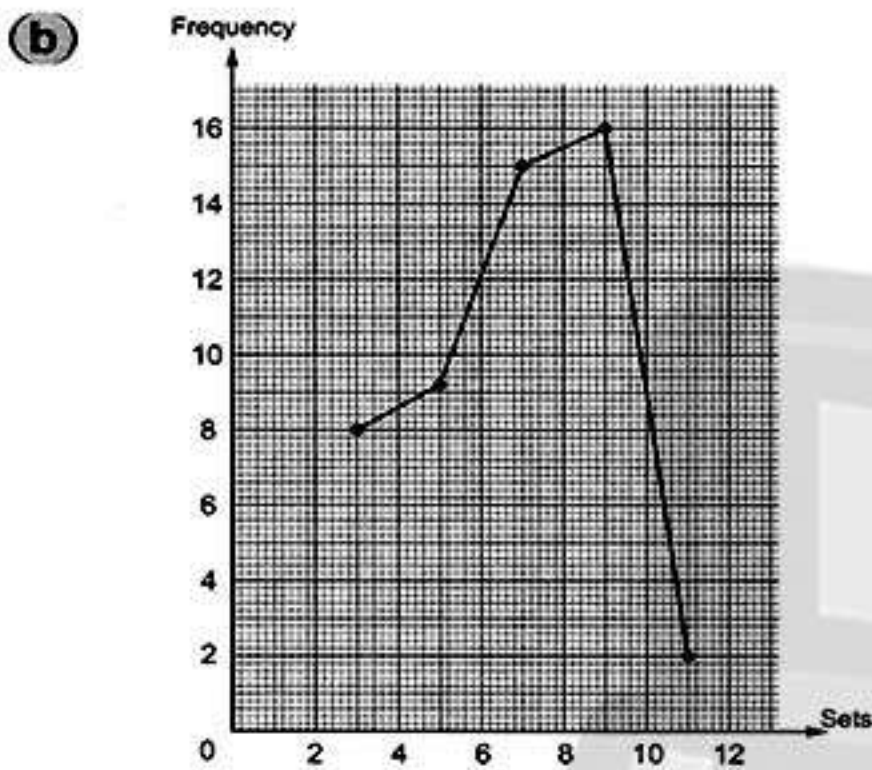

Model 3



1 (a) 12 (b) 18 (c)  $\emptyset$

2 (a) (1)  $x\pi$  (2) 8

(b) The area of the rhombus =  $\frac{1}{2} \times 6 \times 8$   
 $= 24 \text{ cm}^2$

The area of the square =  $\frac{1}{2} \times 8 \times 8$   
 $= 32 \text{ cm}^2$

The area of the square is greater.

(c)  $2x + 9 = 21$      $2x = 21 - 9$   
 $2x = 12$      $x = 12 \div 2$      $x = 6$

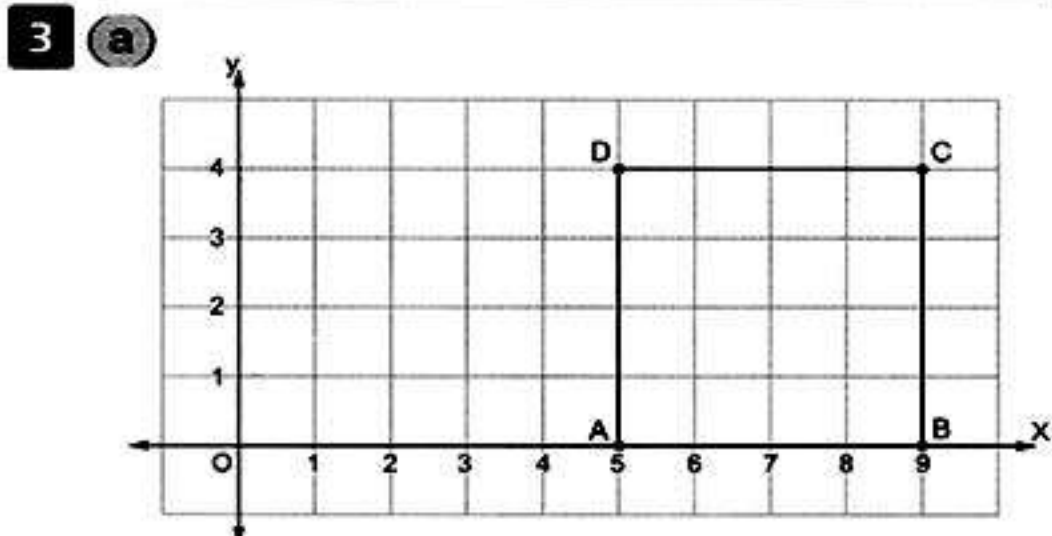

The area of the shape ABCD  
 $= 4 \times 4 = 16 \text{ square units.}$

(b)  $25 \times 9892 \times 4 = 25 \times 4 \times 9892$   
 $= 100 \times 9892$   
 $= 989200$

4 The distance around the figure  
 $= (14 \times \frac{22}{7}) + 28 + 28 = 100 \text{ cm.}$

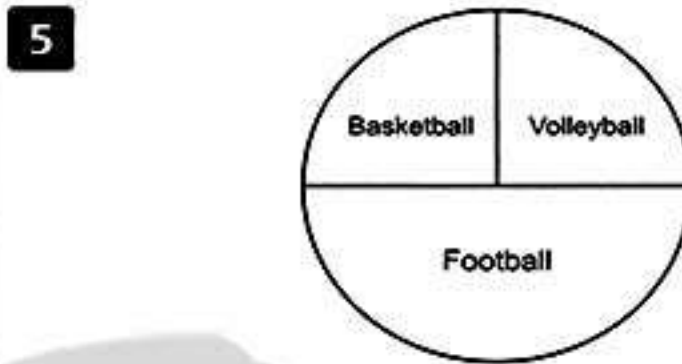

Model 4



1 (a) 1 (b) 5 (c) 100

2 (a)  $2r$  (b) (2, 5) (c) 10 (d) 20

3 (a) The distance around the figure  
 $= (7 \times \frac{22}{7}) + 14 = 36 \text{ cm.}$

(b)  $653 + 548 + 347 = 653 + 347 + 548$   
 $= (653 + 347) + 548$   
 $= 1000 + 548 = 1548$

4 (a)  $X = \{3, 4, 5, 6, 7\}$

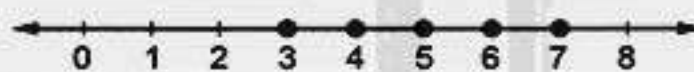

(b) The area of triangle =  $\frac{1}{2} \times 6 \times 8 = 24 \text{ cm}^2$

The length of  $\overline{BD} = \frac{24 \times 2}{10} = 4.8 \text{ cm.}$

(c) The equation is :  $3x - 1 = 8$   
 $3x = 8 + 1$      $3x = 9$      $x = 9 \div 3$      $x = 3$

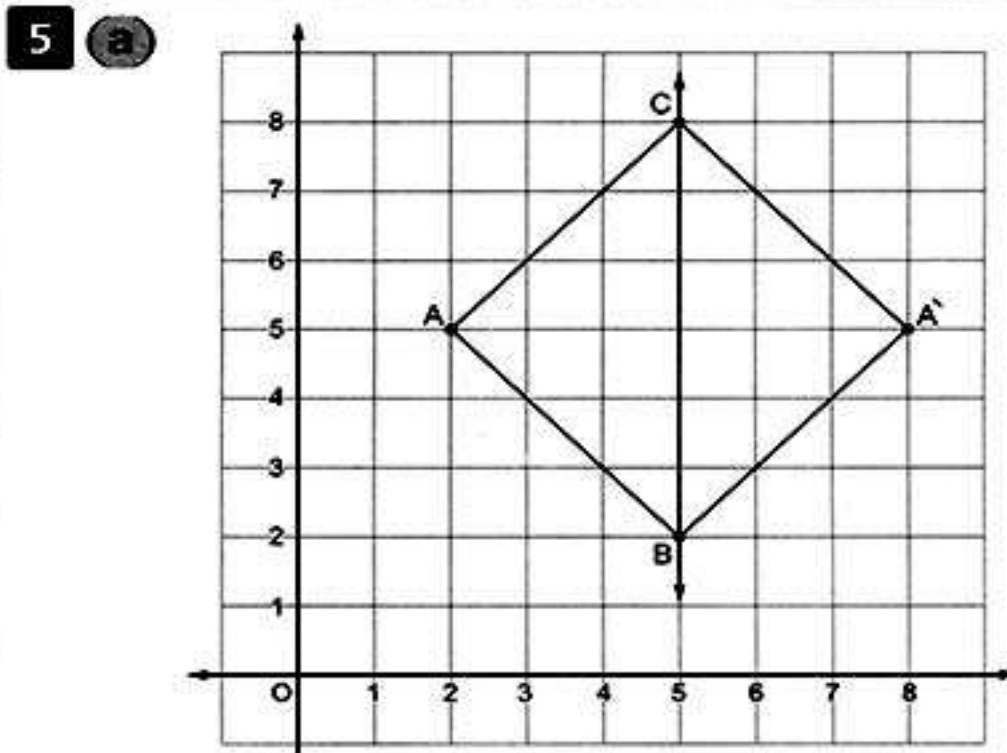

(b) (1) blue (2) 6 (3) 3





Answers of Final examinations

Model 5



- 1 (a) E (b) 1 (c)  $(x + 10)$  pounds  
(d)  $21 - x$  (e)  $100 \text{ cm}^2$

- 2 (a) C (b) even (c)  $2x - 3$   
(d)  $20 \text{ cm}^2$  (e) 2

- 3 (a) The numbers are :  $x + 5$  ,  $x + 7$  ,  $x + 9$  ,  $x + 11$  ,  $x + 13$   
(b) The area of the rhombus =  $\frac{1}{2} \times 8 \times 6 = 24 \text{ cm}^2$   
The area of the parallelogram =  $10 \times 5 = 50 \text{ cm}^2$   
The difference =  $50 - 24 = 26 \text{ cm}^2$

- 4 (a)  $14 - 3x = 8$   
(b) The perimeter =  $(35 \times \frac{22}{7}) + 70 = 180 \text{ cm}$ .

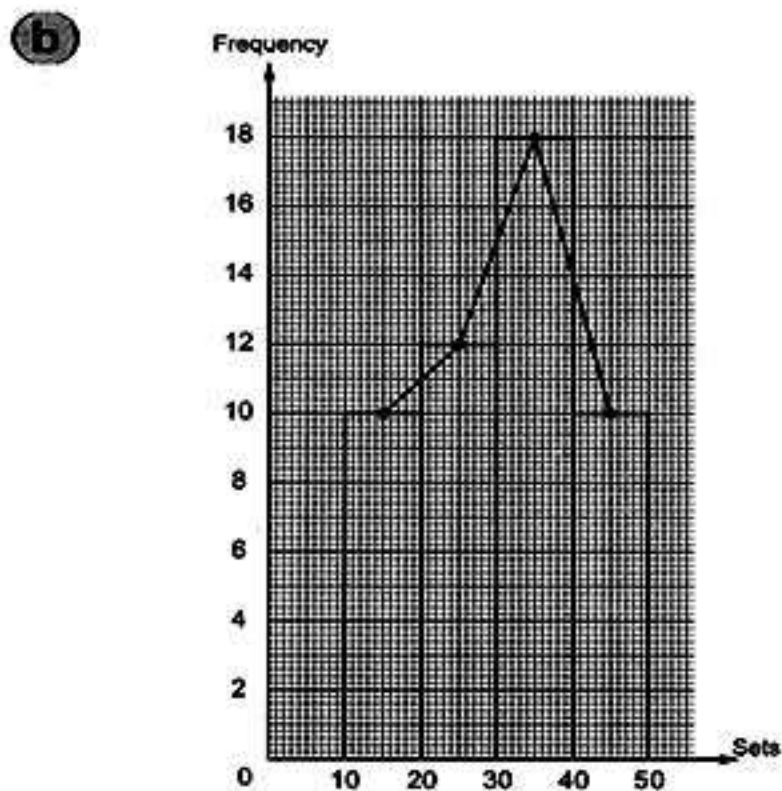
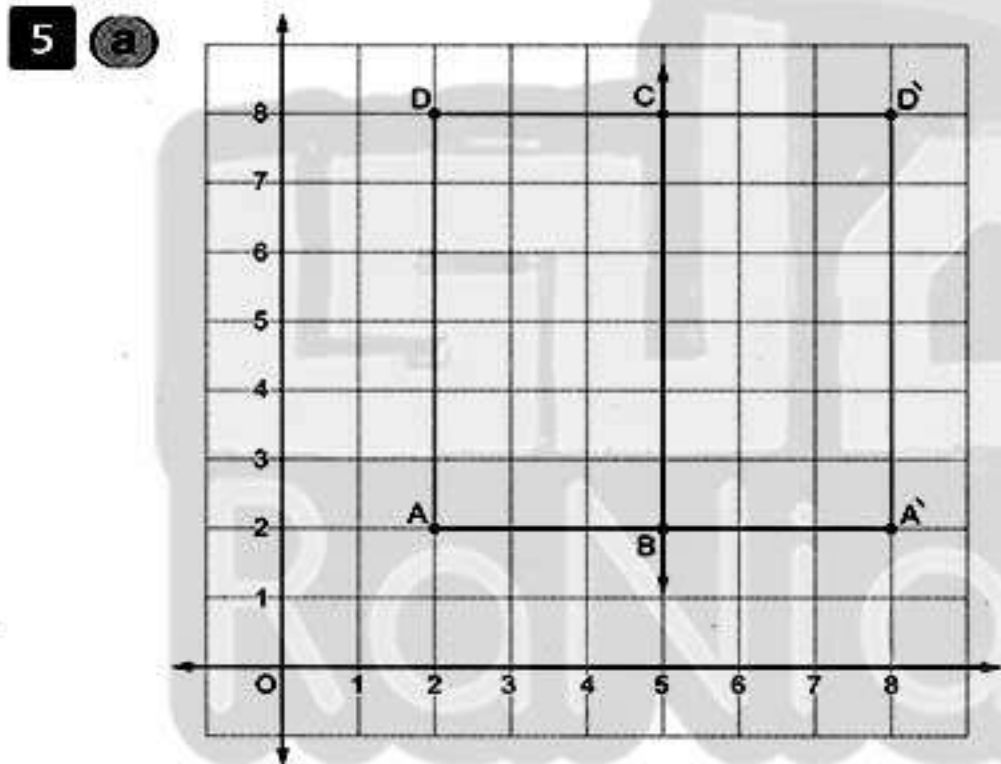

Model 6



- 1 (a) E (b) 9 (c) 60  
(d)  $2y - 4$  (e) odd

- 2 (a) 68 , 59 (b) 2 (c) 3 l cm.  
(d)  $d \times d$  (e) 19

- 3 (a) The area of the triangle =  $\frac{1}{2} \times 12 \times 8 = 48 \text{ cm}^2$   
The area of the parallelogram =  $10 \times 5 = 50 \text{ cm}^2$   
The area of the parallelogram is greater.  
(b) The area of the parallelogram =  $10 \times 12 = 120 \text{ cm}^2$   
 $BC = \frac{120}{8} = 15 \text{ cm}$ .

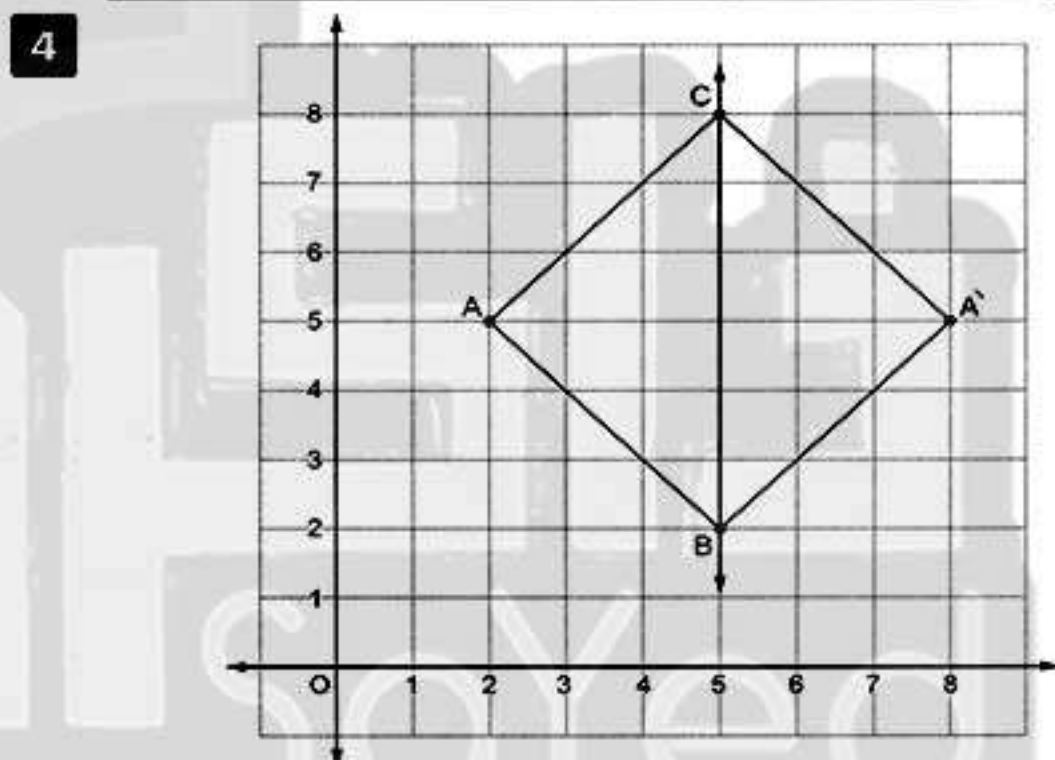

BC = 6 length unit.  
The number of axes of symmetry of the figure = 2 , its area =  $\frac{1}{2} \times 6 \times 6 = 18$  square unit.

- 5 (a) (1)  $x = 9$  (2)  $x = 6$

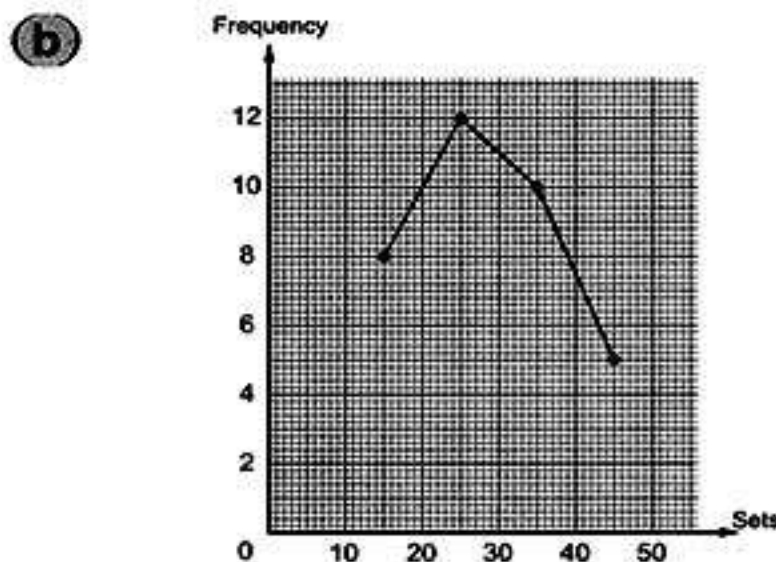



Answers of final examinations

Model 7



- 1 (a) 7 (b) 32 (c) {3, 4}  
 (d)  $\subset$  (e) 15
- 2 (a) 35, 36, 100, 135 (b) 9 (c) 12  
 (d) 19 (e) 11
- 3 (a) The covered distance if the wheel turns one turn =  $56 \times \frac{22}{7} = 176$  cm.  
 The number of turns =  $35200 \div 176 = 200$   
 (b)  $x - 2y = 7$   
 (c) (1)  $(x + 7)$  years (2)  $(x - 10)$  years
- 4 (a) (1)  $8 \times 125 \times 137 = (8 \times 125) \times 137$   
 $= 1000 \times 137 = 137000$   
 (2)  $28 + 72 + 59 = (28 + 72) + 59$   
 $= 100 + 59 = 159$   
 (b)  $DC = \frac{828}{23} = 36$  cm,  $EC = 35 - 23 = 12$  cm.  
 The area of  $\Delta DCE = \frac{1}{2} \times 12 \times 36$   
 $= 216$  cm<sup>2</sup>.

- 5 (a) (1) A = 9

(2) Frequency

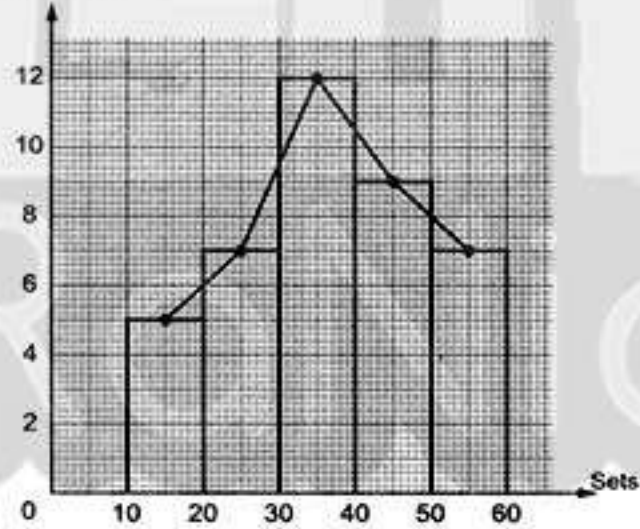

(b)

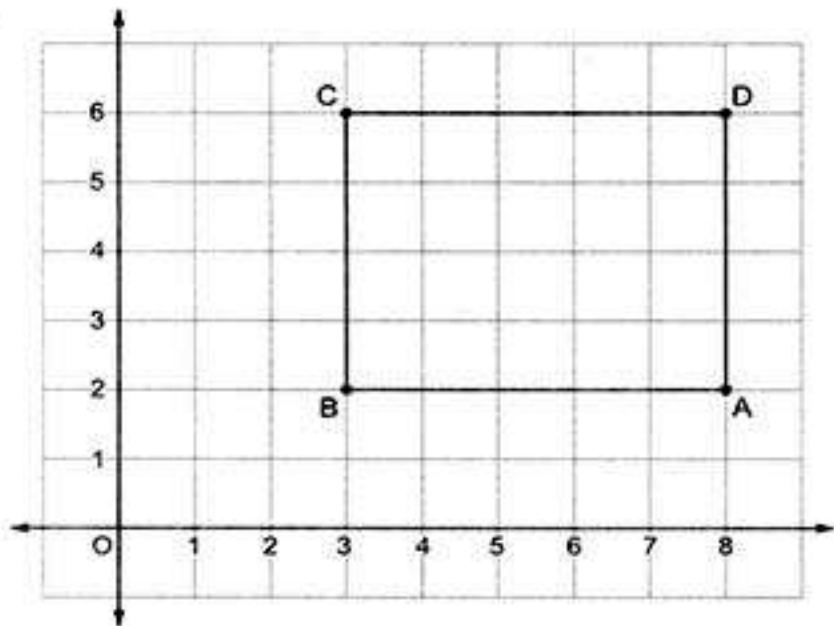

- (1) 5 (2) 4  
 (3) a rectangle (4) 18

Model 8



- 1 (a) 28 (b)  $2x - 7$  (c) {0, 1, 2}  
 (d) 81 (e) 48
- 2 (a) 4 (b) 44  
 (c) {2, 3, 5, 7, 11, 13}  
 (d) 15 (e) 100, 7400
- 3 (a) (1)  $519(100 - 1)$   
 $= 519 \times 100 - 519 \times 1$   
 $= 51900 - 519 = 51381$   
 (2)  $316(1000 + 1)$   
 $= 316 \times 1000 + 316 \times 1$   
 $= 316000 + 316 = 316316$   
 (b) (1) 8 (2) 28 (3) 84

4

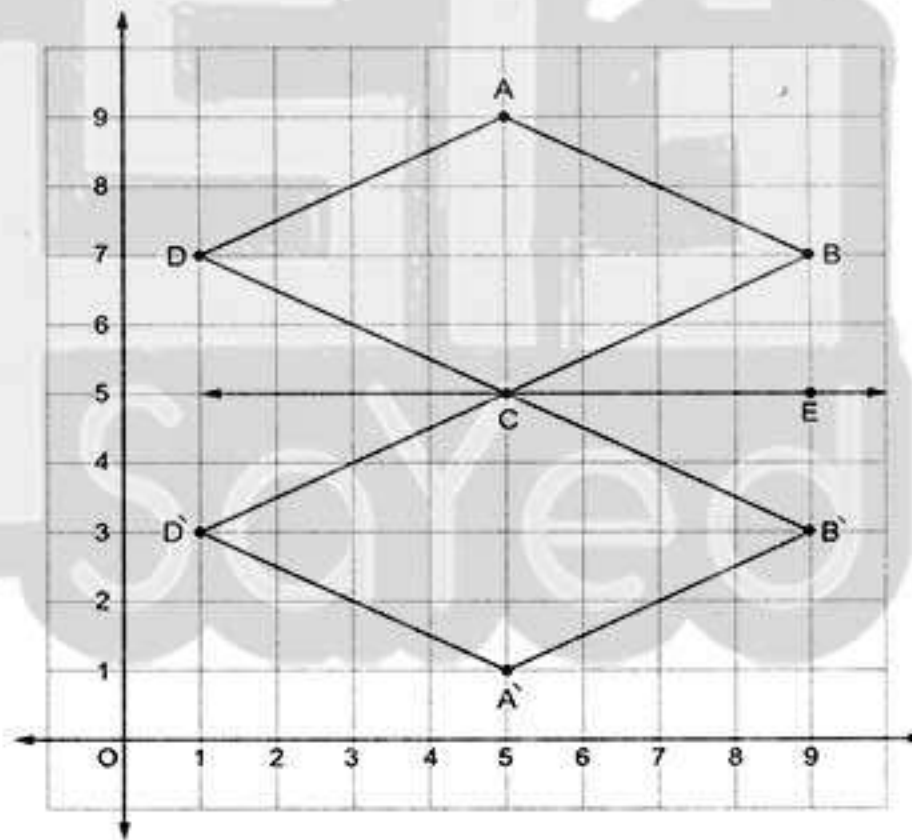

A(5, 1), B(9, 3), C(5, 5) and D(1, 3)  
 The figure ABCD is a rhombus, the area of the figure ABCD =  $\frac{1}{2} \times 8 \times 4 = 16$  square unit.

- 5 (a) (1)  $x = 2$  (2)  $x = 4$

(b)

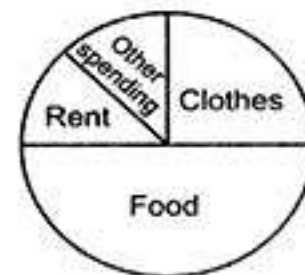





## Answers of Final examinations

## Model 9



1 (a)  $\{3, 2\}$  (b)  $\notin$  (c) 10

(d) 28 (e) 20

2 (a)  $\emptyset$  (b)  $3y + 5$  (c)  $(8 - x)$  cm.

(d) 6 cm. (e) 9

3 (a) (1)  $x = 6$  (2)  $x = 30$

(b) The area of rectangle = the area of square =  $\frac{1}{2} \times 12 \times 12 = 72 \text{ cm}^2$   
 , the length of the rectangle =  $\frac{72}{8} = 9 \text{ cm.}$   
 , the perimeter of the rectangle =  $(8 + 9) \times 2 = 34 \text{ cm.}$

4 (a) The distance covered if the bicycle turns one turn =  $50 \times 3.14 = 157 \text{ cm.}$   
 $= 1.57 \text{ m.}$

the distance covered if the bicycle turns 1200 turns =  $1.57 \times 1200 = 1884 \text{ m.}$

(b)

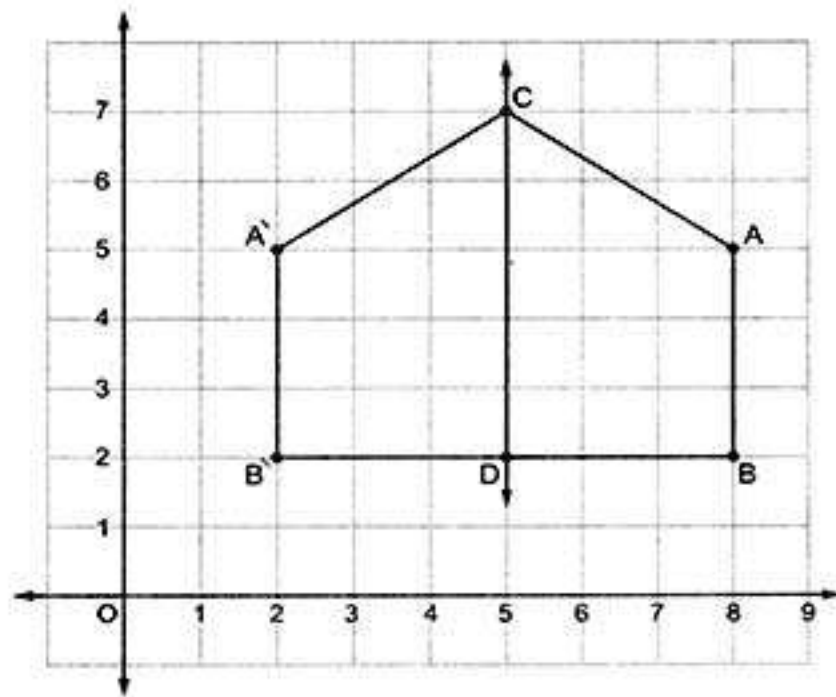

A (2, 5), B (2, 2), D (5, 2) and C (5, 7)

5

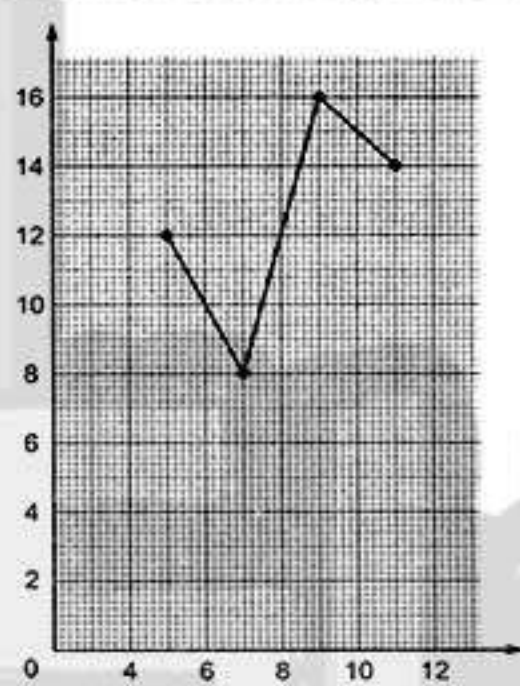









## Answers of Final examinations

## Model 3



1 (a) 0 (b) 12 (c)  $7 + y$  (d) even

2 (a) 0, 1 (b) 5 (c)  $3y + 7$  (d) (2, 5)

3 (a) (1)  $98 \times 37 = (100 - 2) \times 37$   
 $= 100 \times 37 - 2 \times 37$   
 $= 3700 - 74 = 3626$

(2)  $299 \times 17 = (300 - 1) \times 17$   
 $= 300 \times 17 - 1 \times 17$   
 $= 5100 - 17 = 5083$

(b) (1)  $3x + 8 = 29$   $3x = 29 - 8$   $3x = 21$   
 $x = \frac{21}{3}$   $x = 7$

(2)  $\frac{1}{7}x - 3 = 1$   $\frac{1}{7}x = 1 + 3$   $\frac{1}{7}x = 4$   
 $x = 4 \times 7$   $x = 28$

4 (a) The area of the rhombus =  $\frac{1}{2} \times 12 \times 16$   
 $= 96 \text{ cm}^2$

The side length =  $96 \div 9.6 = 10 \text{ cm}$ .

(b) (1)  $\overline{EF}$  (2)  $\overline{DF}$

5 (a) The circumference of the wheel =  $50 \times 3.14$   
 $= 157 \text{ cm}$   
 $= 1.57 \text{ m}$

The distance =  $1.57 \times 1000 = 1570 \text{ m}$ .

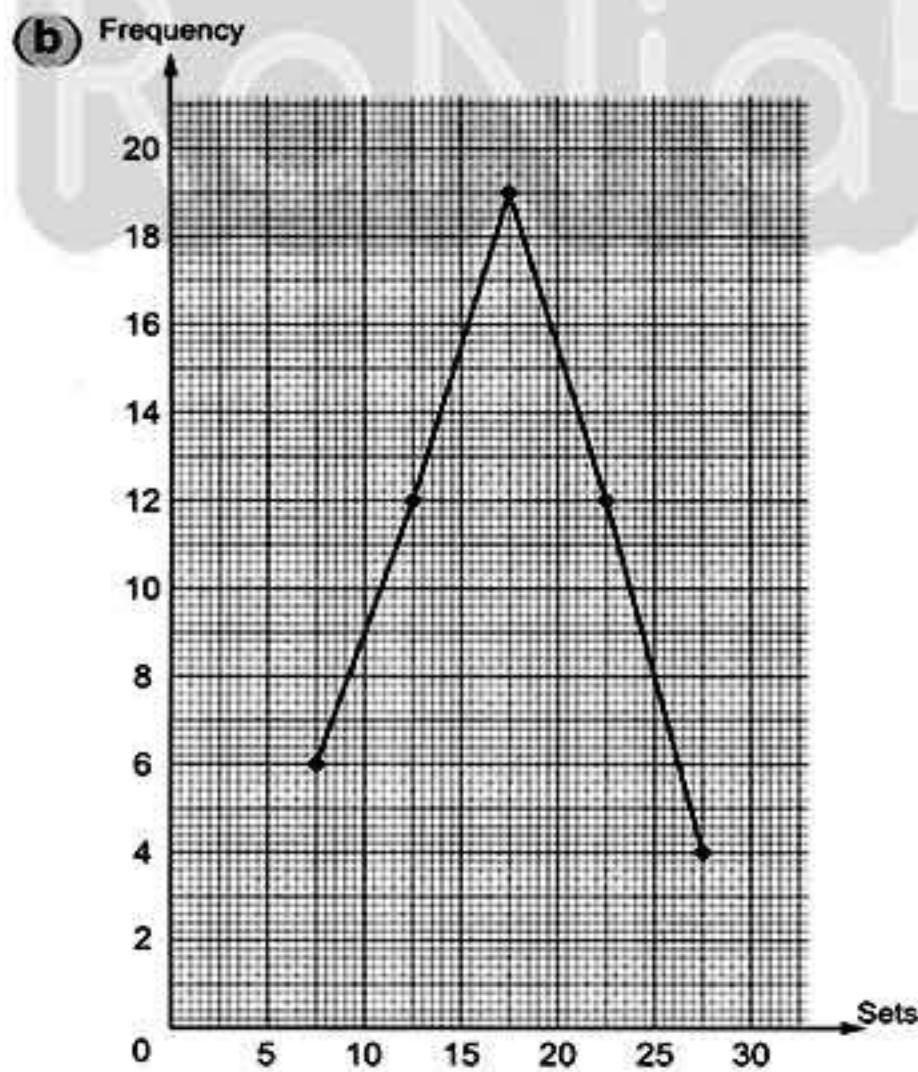

## Model 4



1 (a) an odd (b)  $4x$  (c) 3 (d) 25

2 (a) {1, 2, 3, 4, 5} (b) rotation  
(c) 15 (d)  $5 - x$

3 (a)

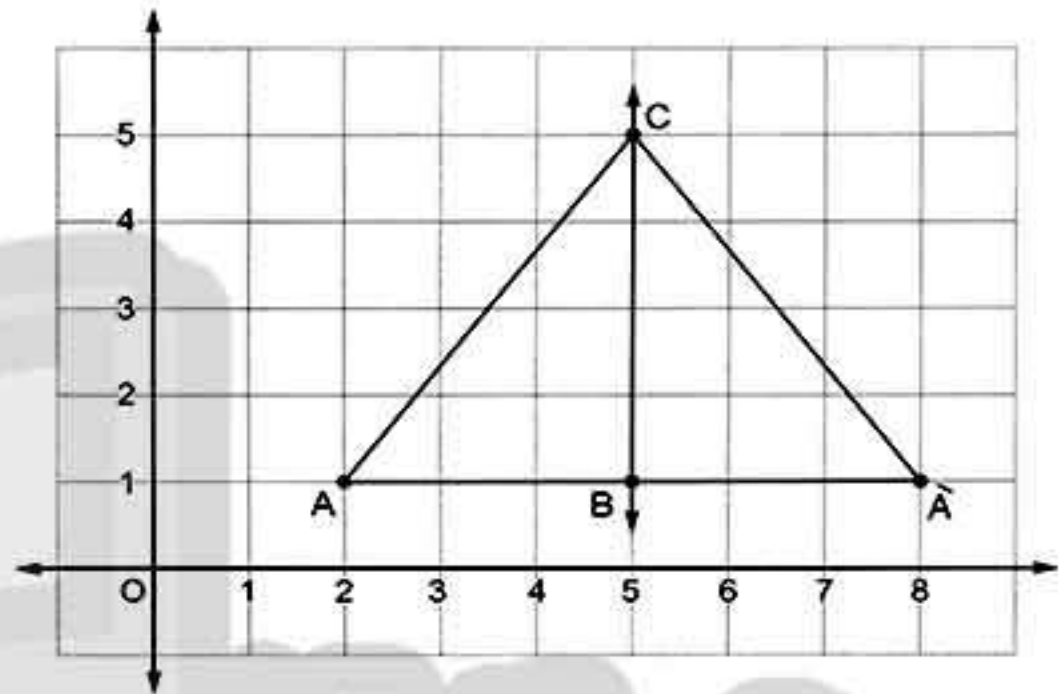

The sum of areas =  $2 \times \frac{1}{2} \times 3 \times 4$   
 $= 12 \text{ area unit}$ .

(b) (1)  $123 + 254 + 377 + 246$   
 $= 123 + 377 + 254 + 246$   
 $= (123 + 377) + (254 + 246)$   
 $= 500 + 500 = 1000$

(2)  $25 \times 125 \times 4 = 25 \times 4 \times 125$   
 $= (25 \times 4) \times 125$   
 $= 100 \times 125 = 12500$

4 (a) The area =  $12 \times 5 = 60 \text{ cm}^2$   
The height =  $\frac{60}{6} = 10 \text{ cm}$ .

(b) (1)  $\frac{1}{3}x + 8 = 10$   $\frac{1}{3}x = 10 - 8$   
 $\frac{1}{3}x = 2$   $x = 2 \times 3$   $x = 6$

(2)  $\frac{1}{6}x - 3 = 4$   $\frac{1}{6}x = 4 + 3$   $\frac{1}{6}x = 7$   
 $x = 7 \times 6$   $x = 42$

5 (a)

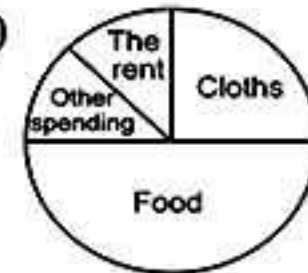

(b) The perimeter =  $(\frac{1}{4} \times 2 \times \frac{22}{7} \times 7) + 7 + 7$   
 $= 11 + 14 = 25 \text{ cm}$ .



## Answers of final examinations

## Model 5



1 (a)  $2x - 7$  (b) 2 (c)  $\emptyset$  (d) 22

2 (a)  $\in$  (b) (5, 4) (c) 1 (d)  $5L - 6$

3 (a)  $3x + 5 = 20$     $3x = 20 - 5$     $3x = 15$   
 $x = \frac{15}{3}$     $x = 5$

The price of each notebook is L.E. 5

(b) (1)  $25 \times 98 \times 4 = 25 \times 4 \times 98$   
 $= (25 \times 4) \times 98$   
 $= 100 \times 98 = 9800$

(2)  $642 + 173 + 358 + 27$   
 $= 642 + 358 + 173 + 27$   
 $= (642 + 358) + (173 + 27)$   
 $= 1000 + 200 = 1200$

4 (a) The height =  $48 + 8 = 6$  cm.

(b) The area of  $\triangle ABC = \frac{1}{2} \times 6 \times 8 = 24$  cm<sup>2</sup>.

The area of  $\triangle EBC = \frac{1}{2} \times 6 \times 4 = 12$  cm<sup>2</sup>.

The area of the shaded part =  $24 - 12$   
 $= 12$  cm<sup>2</sup>.

5 (a)

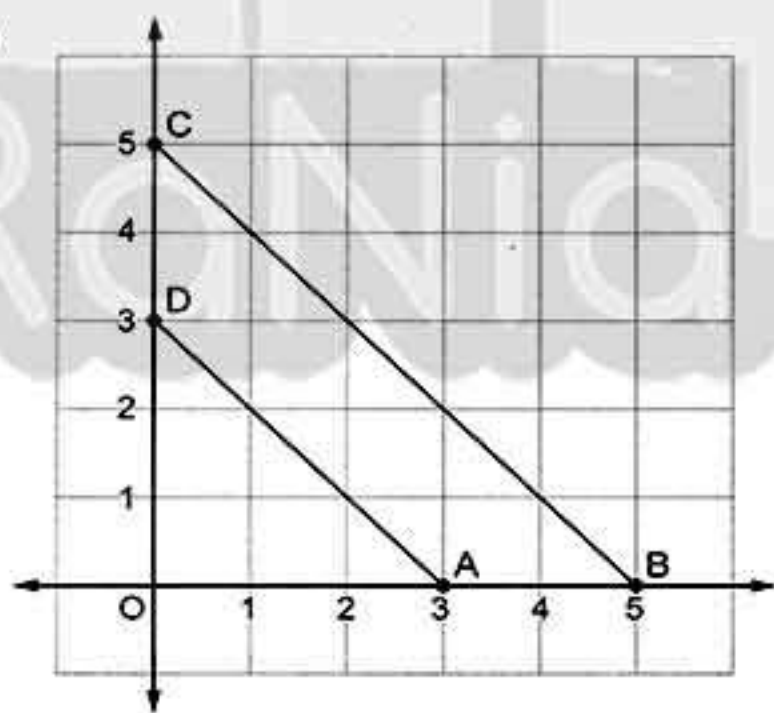

The area of  $\triangle AOD = \frac{1}{2} \times 3 \times 3$   
 $= 4.5$  area unit.

The area of  $\triangle BOC = \frac{1}{2} \times 5 \times 5$   
 $= 12.5$  area unit.

The area of the shape ABCD  
 $= 12.5 - 4.5 = 8$  area unit.

(b) Frequency

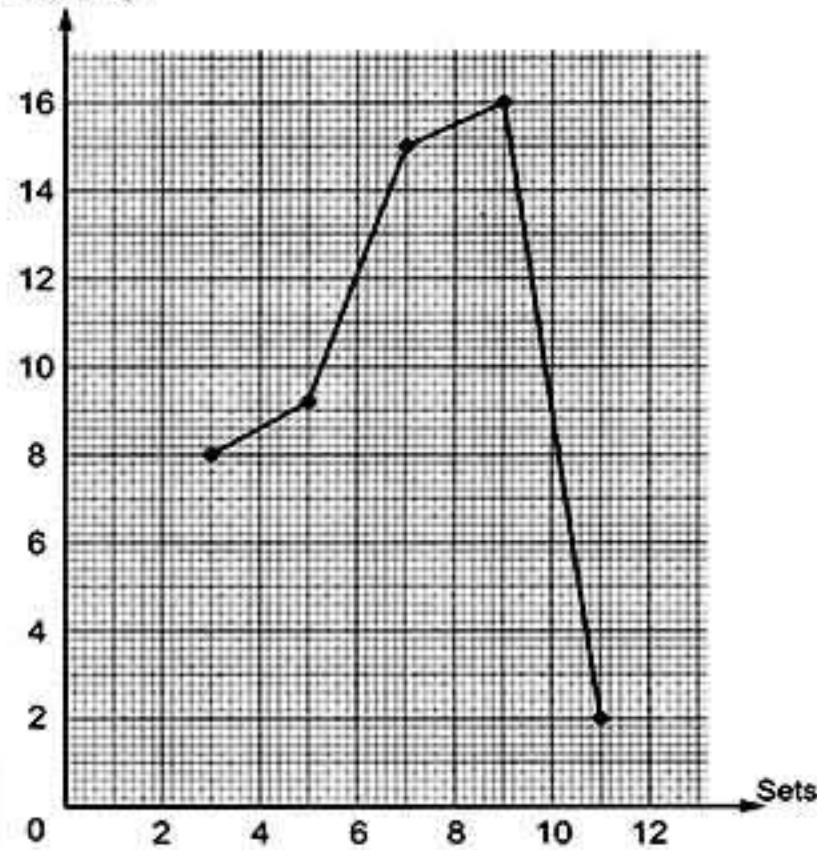

## Model 6



1 (a)  $\neq$  (b) zero (c)  $2x - 3$  (d) {2}

2 (a) 19, 26 (b)  $x + 10$   
(c) translation (d) 32

3 (a) The length of  $\overline{CE} = 35 - 23 = 12$  cm.  
The length of  $\overline{CD} = 828 + 23 = 36$  cm.  
The area of  $\triangle DCE = \frac{1}{2} \times 12 \times 36 = 216$  cm<sup>2</sup>.

(b) (1)  $8 \times 133 \times 125 = 8 \times 125 \times 133$   
 $= (8 \times 125) \times 133$   
 $= 1000 \times 133 = 133000$   
(2)  $27 + 69 + 73 = 27 + 73 + 69$   
 $= (27 + 73) + 69$   
 $= 100 + 69 = 169$

4 (a) The perimeter =  $(6 \times 3.14) + 10 + 10$   
 $= 18.84 + 10 + 10$   
 $= 38.84$  cm.

(b) (1)  $\frac{1}{3}x + 8 = 9$     $\frac{1}{3}x = 9 - 8$     $\frac{1}{3}x = 1$   
 $x = 1 \times 3$     $x = 3$   
(2)  $2x - 3 = 5$     $2x = 5 + 3$     $2x = 8$   
 $x = 8 + 2$     $x = 4$





Answers of Final examinations

5 (a)

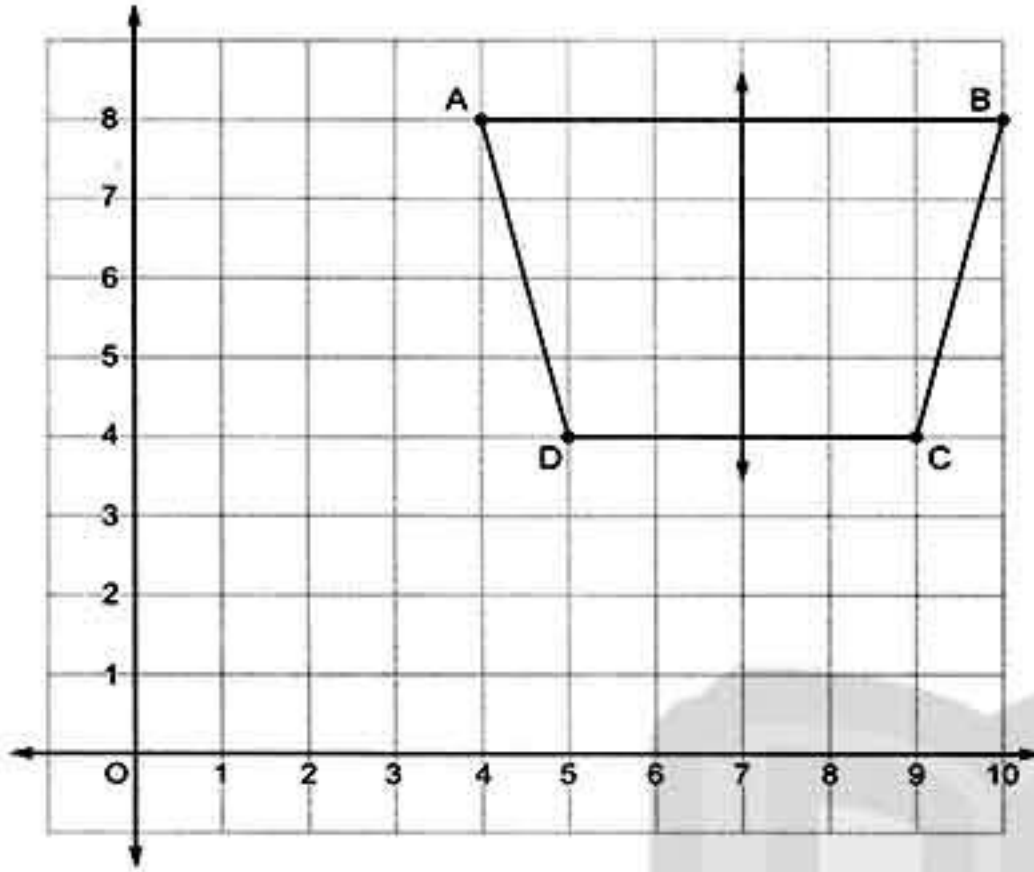

(b)

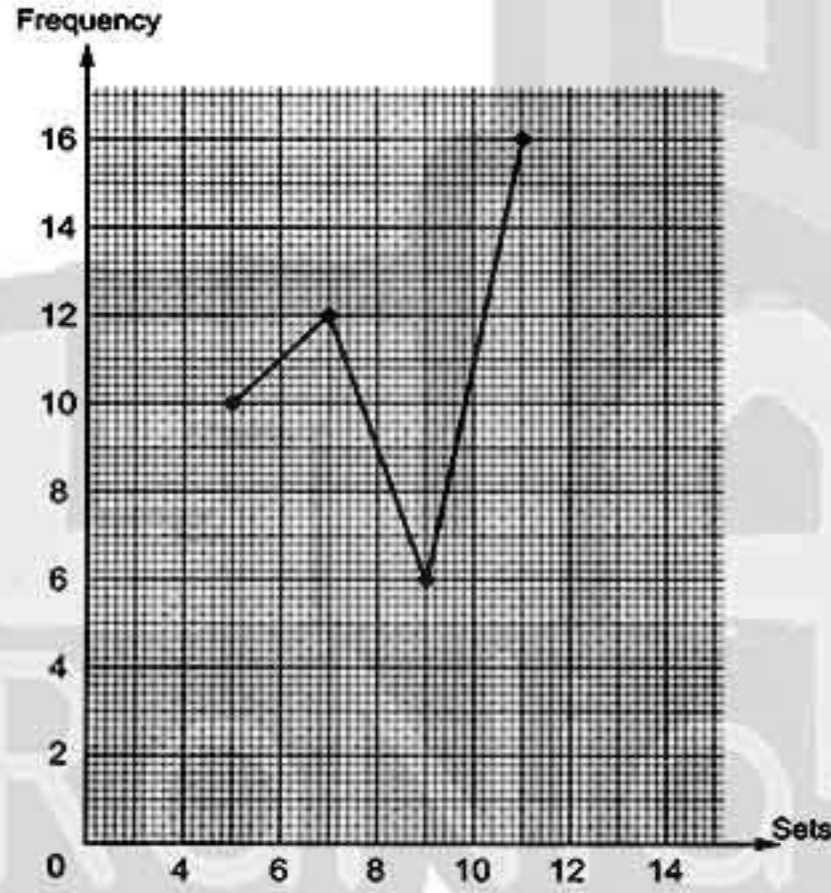

Model 7



- 1 (a) < (b) 132 (c) odd (d) ∈
- 2 (a) E (b) 2 (c) flip (d) 15 - x
- 3 (a)  $x = \{3, 4, 5, 6, 7, 8\}$
- 
- (b) The numbers are :  $(x + 8)$  ,  $(x + 10)$  ,  $(x + 12)$  ,  $(x + 14)$  and  $(x + 16)$

4 (a) The area of the rhombus =  $\frac{1}{2} \times 6 \times 8$   
 = 24 cm<sup>2</sup>

The area of the square =  $\frac{1}{2} \times 7 \times 7$   
 = 24.5 cm<sup>2</sup>

The area of the square is greater.

- (b) The length of  $\overline{BC} = 32 + 4 = 8$  cm.  
 The area of  $\triangle ABE = \frac{1}{2} \times 3 \times 4 = 6$  cm<sup>2</sup>.  
 The area of the figure AECD = 32 - 6  
 = 26 cm<sup>2</sup>

5 (a)

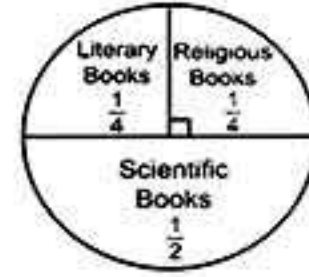

The number of religious books =  $\frac{1}{4} \times 800$   
 = 200 books.

The number of literary books =  $\frac{1}{4} \times 800$   
 = 200 books.

The number of scientific books =  $\frac{1}{2} \times 800$   
 = 400 books.

- (b) (1)  $\overline{EF}$  (2)  $\overline{DF}$  (3)  $\overline{BF}$  (4)  $\overline{BF}$

Model 8



- 1 (a) ⊂ (b)  $x - 3$  (c) 1 (d) flip
- 2 (a) 3l (b) ∅ (c) 81 (d) 28
- 3 (a) The area of the parallelogram = 12 × 5  
 = 60 cm<sup>2</sup>
- The height = 60 ÷ 6 = 10 cm.
- (b) The perimeter =  $(\frac{1}{2} \times 70 \times \frac{22}{7}) + 70$   
 = 110 + 70 = 180 cm.
- 4 (a)  $75 = 5x + 7 \times 10$        $5x + 70 = 75$   
 $5x = 75 - 70$                    $5x = 5$   
 $x = 5 \div 5$                            $x = 1$
- (b)



Answers of final examinations

5 (a)

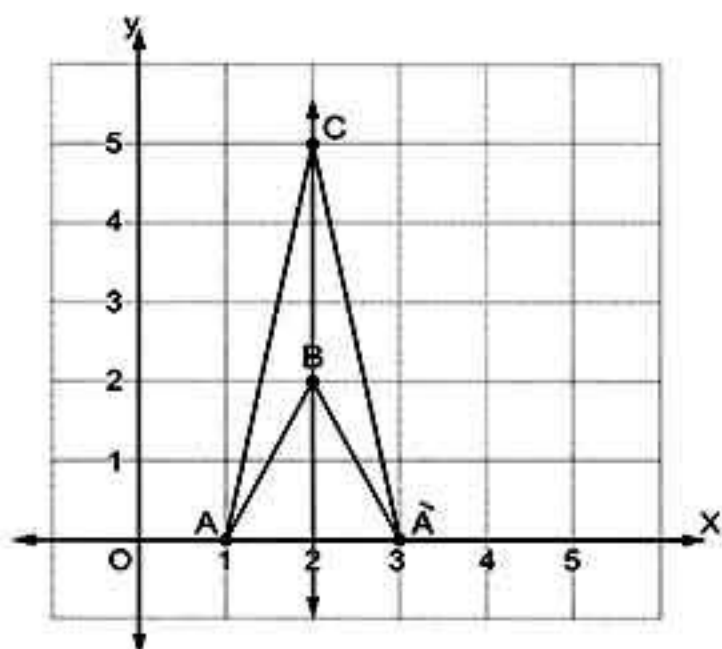

(b) (1) 16

(2) No. of cities

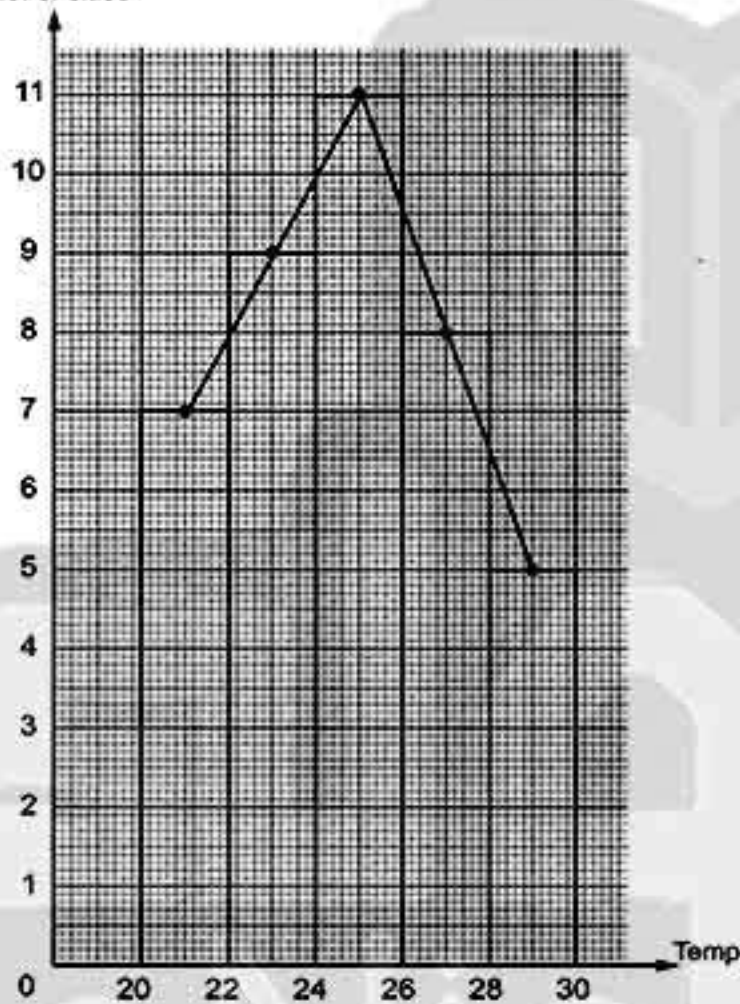

Model 9



1 (a) 0 (b) 30 (c)  $10 - x$  (d) 1

2 (a) 0 (b) 5  
(c) additive identity element (d) (4, 7)

3 (a)  $3x - 1 = 8$      $3x = 8 + 1$      $3x = 9$   
 $x = 9 + 3$          $x = 3$

(b) (1)  $18 \times 99 = 18 \times (100 - 1)$   
 $= 18 \times 100 - 18 \times 1$   
 $= 1800 - 18 = 1782$

(2)  $56 \times 1002 = 56 \times (1000 + 2)$   
 $= 56 \times 1000 + 56 \times 2$   
 $= 56000 + 112 = 56112$

(3)  $4 \times 49 \times 25 = 4 \times 25 \times 49$   
 $= (4 \times 25) \times 49$   
 $= 100 \times 49 = 4900$

(4)  $156 + 871 + 344 + 129$   
 $= 156 + 344 + 871 + 129$   
 $= (156 + 344) + (871 + 129)$   
 $= 500 + 1000 = 1500$

4 (a) The area of  $\triangle ABC = \frac{1}{2} \times 6 \times 8 = 24 \text{ cm}^2$

The length of  $\overline{AD} = \frac{24}{\frac{1}{2} \times 10} = 4.8 \text{ cm}$ .

(b) The area of the rhombus  $= \frac{1}{2} \times 6 \times 8$   
 $= 24 \text{ cm}^2$

The area of the parallelogram  $= 4 \times 8$   
 $= 32 \text{ cm}^2$

The area of the parallelogram is greater.

5 (a)

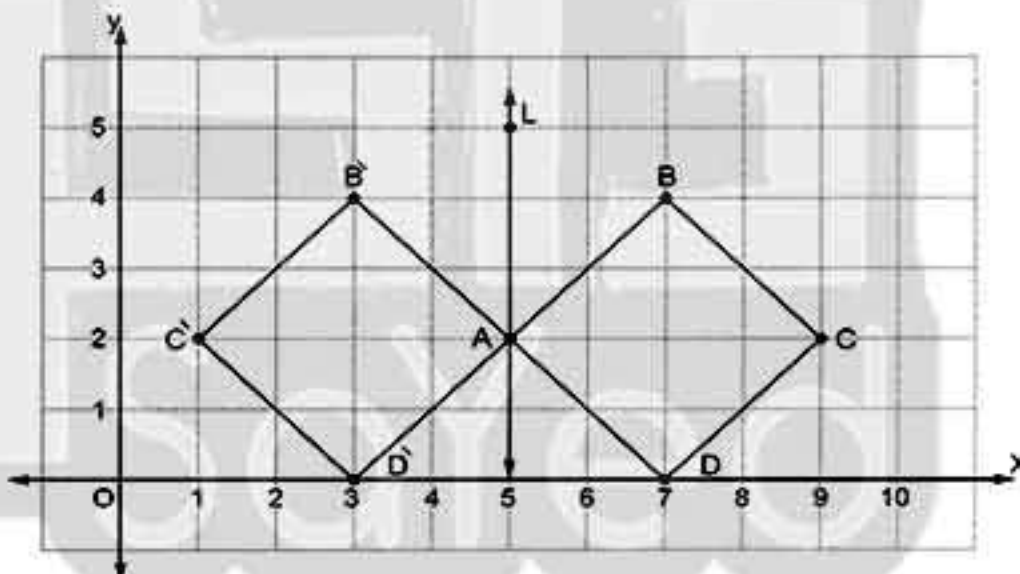

(1) A (5, 2)        (2) B (3, 4)

(3) C (1, 2)        (4) D (3, 0)

(b) Frequency

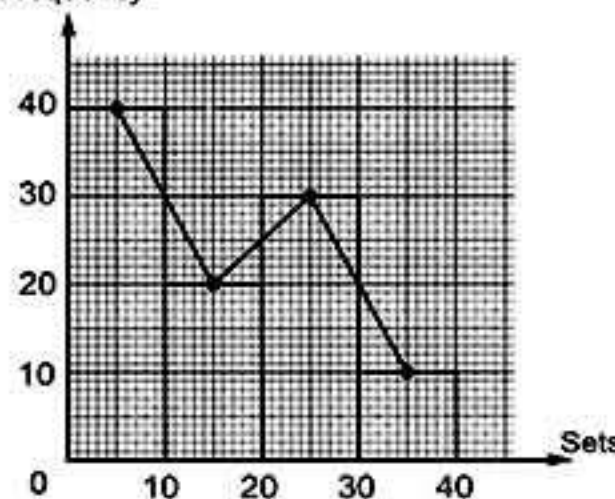





Answers of Final examinations

Model 10



- 1 (a) C (b)  $4x$   
 (c) 3 (d) reflection
- 2 (a) {1, 2, 3, 4} (b)  $2Z - 5$   
 (c) 20 (d) odd
- 3 (a) The area of one square =  $\frac{1}{2} \times 9 \times 9$   
 =  $40.5 \text{ cm}^2$   
 The area of the left part  
 =  $312.5 - (7 \times 40.5) = 29 \text{ cm}^2$   
 (b) The radius length =  $\frac{66}{2 \times \frac{22}{7}} = 10.5 \text{ cm}$ .
- 4 (a) (1)  $25 \times 4 \times 9892 = (25 \times 4) \times 9892$   
 =  $100 \times 9892 = 989200$   
 (2)  $862 + 138 + 199 + 801$   
 =  $(862 + 138) + (199 + 801)$   
 =  $1000 + 1000 = 2000$   
 (b)  $2x + 3 = 15$        $2x = 15 - 3$   
 $2x = 12$                $x = 12 \div 2$   
 $x = 6$

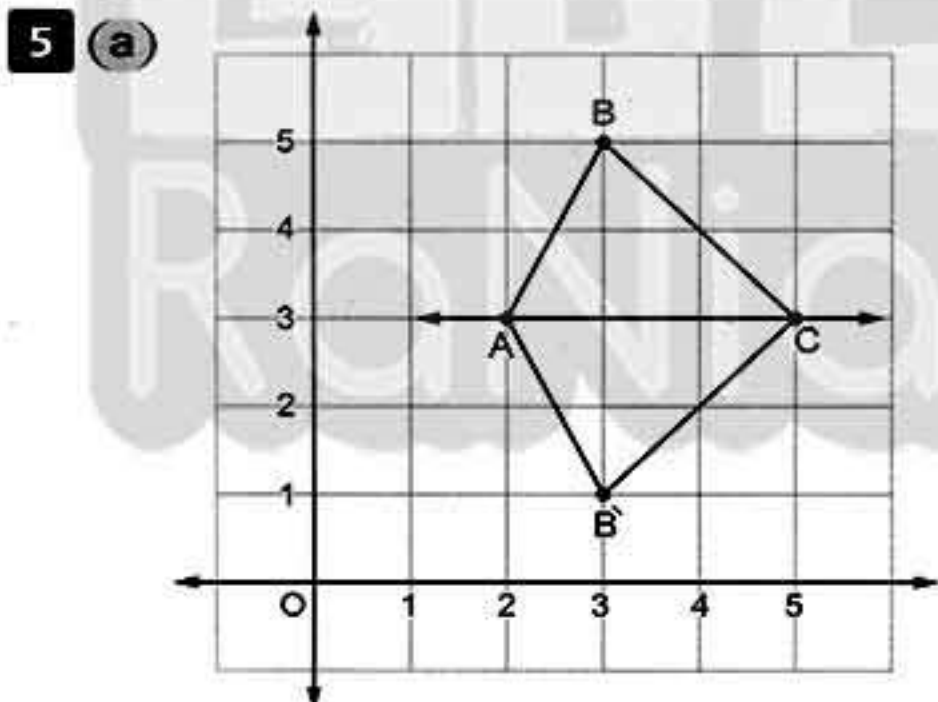

- (b) Football =  $\frac{20}{40} = \frac{1}{2}$   
 Basketball =  $\frac{10}{40} = \frac{1}{4}$   
 Volleyball =  $\frac{10}{40} = \frac{1}{4}$

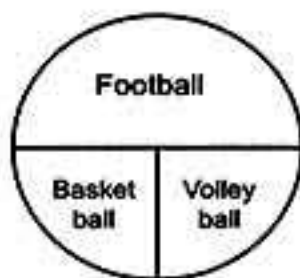

Model 11



- 1 (a)  $\notin$  (b) 0  
 (c) translation (d)  $2\pi r$

- 2 (a) 3 (b) 3, 6, 12, 24, 48, 96  
 (c)  $2(x+y)$  (d) (2, 5)
- 3 (a)  $x + 13, x + 11, x + 9, x + 7$  and  $x + 5$   
 (b) The area of the parallelogram ABCD  
 =  $10 \times 12 = 120 \text{ cm}^2$   
 The length of  $\overline{BC} = \frac{120}{8} = 15 \text{ cm}$ .
- 4 (a) (1)  $3x + 5 = 26$        $x = 26 - 5$   
 $3x = 21$        $x = 21 \div 3$        $x = 7$   
 (2)  $\frac{1}{5}x - 2 = 10$        $\frac{1}{5}x = 10 + 2$   
 $\frac{1}{5}x = 12$        $x = 12 \times 5$        $x = 60$   
 (b) The height =  $\frac{6}{\frac{1}{2} \times 3} = 4 \text{ cm}$ .

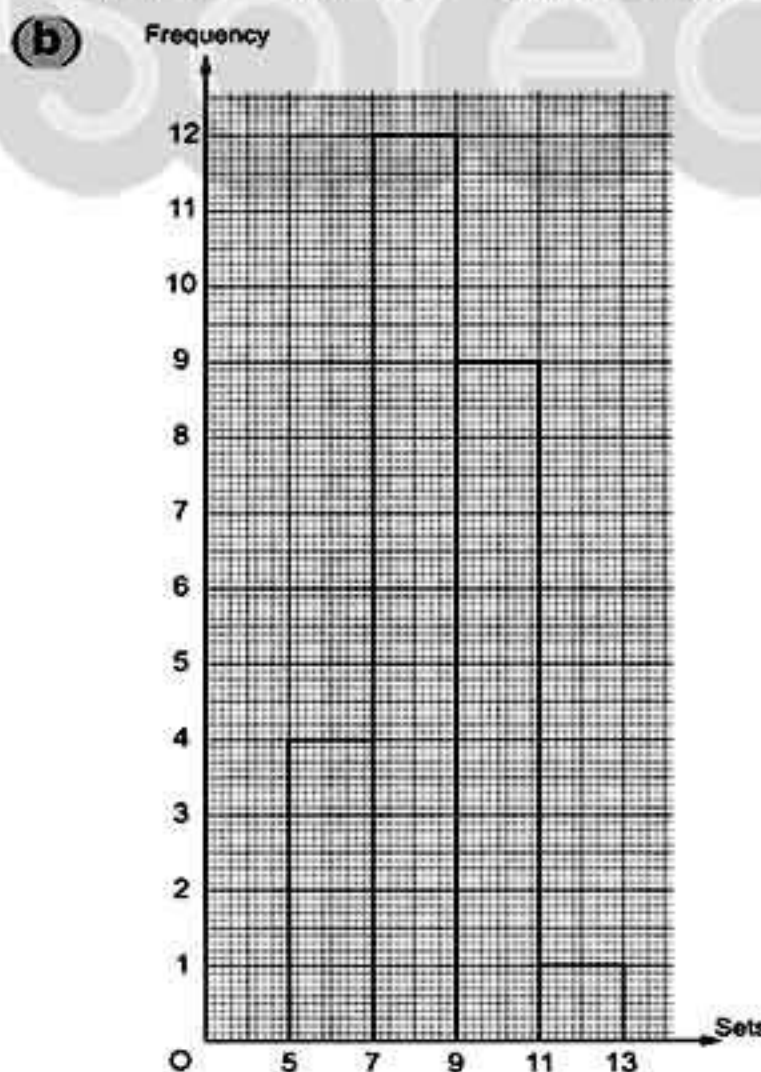
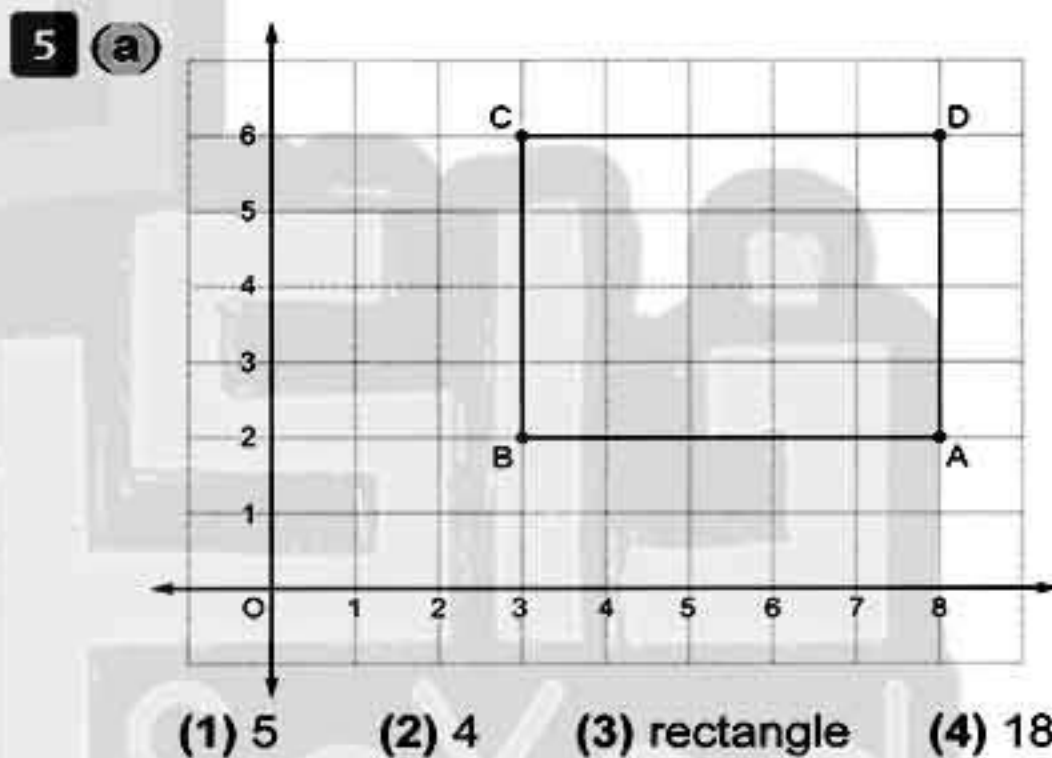



Answers of final examinations

Model 12



- 1 (a) odd (b) 4 (c) 20 (d) <
- 2 (a) 1 (b)  $10 - x$  (c) 7 (d) {2}
- 3 (a) The circumference of the semicircle  
 $= \frac{1}{2} \times 70 \times \frac{22}{7} = 110 \text{ cm.}$   
 The perimeter of the window  
 $= 110 + 70 + 70 + 70 = 320 \text{ cm.}$
- (b) The area of the square  $= 70 \times 70$   
 $= 4900 \text{ cm}^2$
- The area of the semicircle  
 $= 6825 - 4900 = 1925 \text{ cm}^2$
- 4 (a)  $38 + 47 + 62 + 53 = 38 + 62 + 47 + 53$   
 $= (38 + 62) + (47 + 53) = 100 + 100 = 200$
- (b)  $x + 45 = 75$      $x = 75 - 45$      $x = 30$

5 (a)

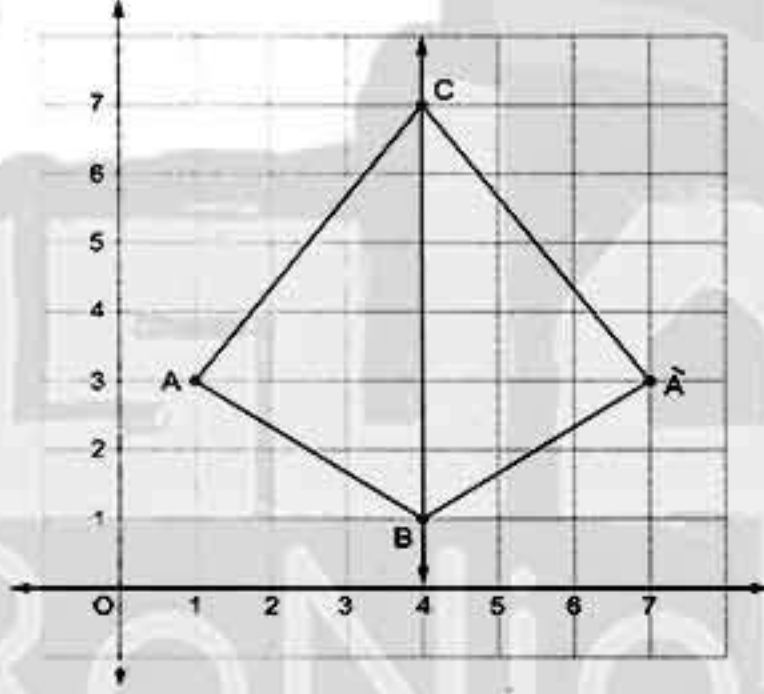

(b) Frequency

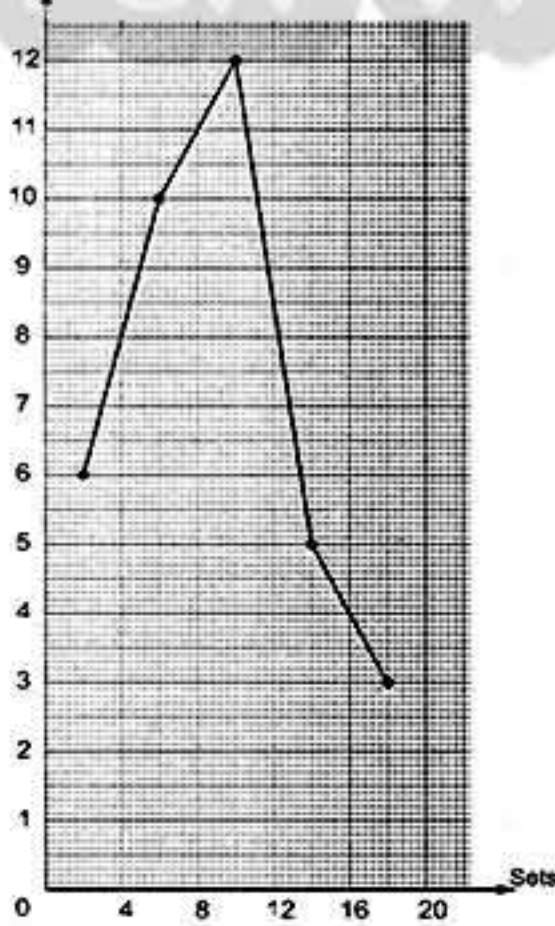

Model 13



- 1 (a)  $\neq$  (b)  $2x - 7$  (c) 0 (d) 15
- 2 (a) 81, 243 (b)  $35 - x$   
 (c) 96 (d) translation
- 3 (a) The perimeter  $= (3.5 \times \frac{22}{7}) + 7 + 7 = 25 \text{ cm.}$   
 (b) The area  $= 8 \times 5 = 40 \text{ cm}^2$
- 4 (a) (1)  $519 \times 99 = 519 \times (100 - 1)$   
 $= 519 \times 100 - 519 \times 1$   
 $= 51900 - 519 = 51381$
- (2)  $316 \times 1001 = 316 \times (1000 + 1)$   
 $= 316 \times 1000 + 316 \times 1$   
 $= 316000 + 316 = 316316$
- (b) (1)  $\frac{1}{5}x - 1 = 10$      $\frac{1}{5}x = 10 + 1$   
 $\frac{1}{5}x = 11$      $x = 11 + \frac{1}{5}$      $x = 55$
- (2)  $5x + 1 = 16$      $5x = 16 - 1$   
 $5x = 15$      $x = 15 + 5$      $x = 3$

5 (a)

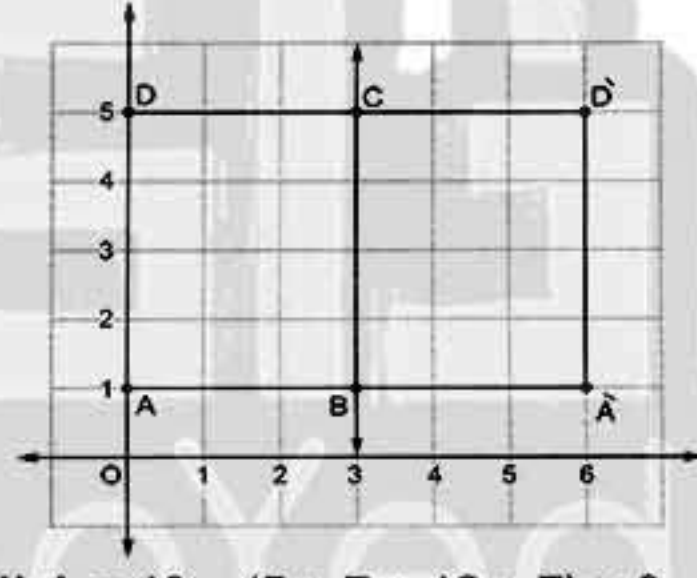

(b) (1)  $A = 40 - (5 + 7 + 12 + 7) = 9$

(2) Frequency

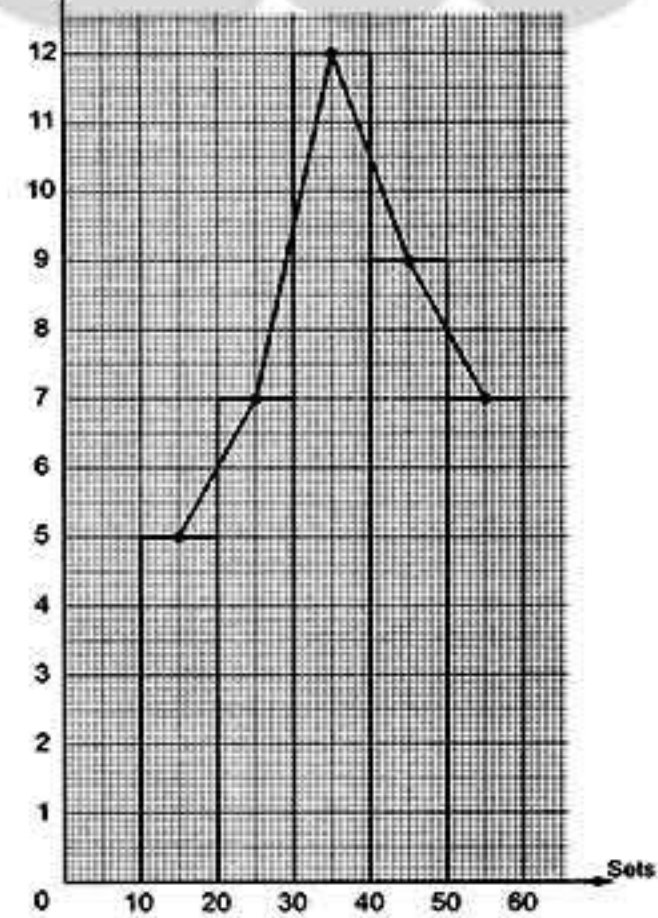





## Answers of Final examinations

## Model 14



1 (a) {0} (b)  $y + 5$  (c) 0 (d)  $\in$

2 (a) 6, 2 (b) 6 (c)  $\pi$  (d) 5

3 (a) (1)  $612 + 154 + 88 + 846$   
 $= 612 + 88 + 154 + 846$   
 (commutative property)  
 $= (612 + 88) + (154 + 846)$   
 (Associative property)  
 $= 700 + 1000 = 1700$

(2)  $125 \times 19 \times 8 = 125 \times 8 \times 19$   
 (Commutative property)  
 $= (125 \times 8) \times 19$  (Associative property)  
 $= 1000 \times 19 = 19000$

(b)  $2x - 4 = 8$       $2x = 8 + 4$   
 $2x = 12$       $x = 12 \div 2$       $x = 6$

4 (a) The area of the triangle ABE =  $\frac{1}{2} \times 4 \times 4$   
 $= 8 \text{ cm}^2$   
 The area of the shaded part =  $32 - 8$   
 $= 24 \text{ cm}^2$

(b) The perimeter =  $(35 \times \frac{22}{7}) + 70 + 70$   
 $= 250 \text{ cm}$ .

5 (a)

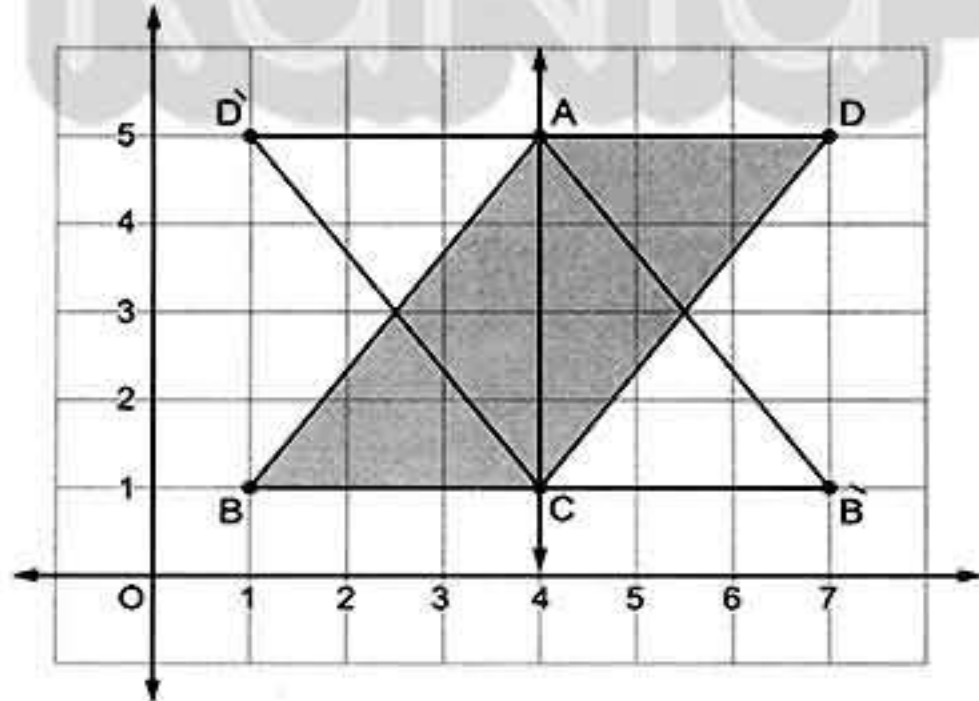

(1) Parallelogram

The area =  $3 \times 4 = 12$  square units.

(2) Drawn in the figure.

(b) Clothes =  $\frac{200}{1600} = \frac{1}{8}$

Food =  $\frac{800}{1600} = \frac{1}{2}$

Transportation and medicine =  $\frac{400}{1600} = \frac{1}{4}$

Renting on apartment =  $\frac{200}{1600} = \frac{1}{8}$

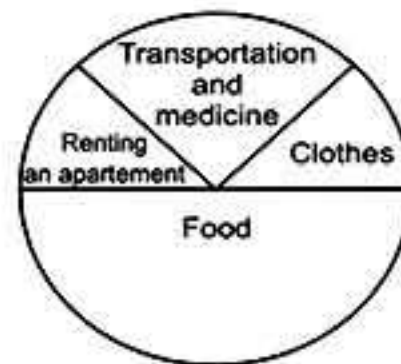

## Model 15



1 (a)  $\mathbb{N}$  (b) 11 (c) 0 (d)  $<$

2 (a) 0, 1 (b)  $3y + 2$  (c) (5, 8) (d) 7

3 (a) Dina has  $x$  pounds and her father gave her 5 pounds, then the total what she has is 12 pounds.

$x + 5 = 12$       $x = 12 - 5$       $x = 7$

(b)  $99 \times 15 = (100 - 1) \times 15 = 15 \times 100 - 15 \times 1$   
 $= 1500 - 15 = 1485$

4 (a) The area of the garden =  $\frac{1}{2} \times 8 \times 7$   
 $= 28 \text{ m}^2$

The area of the land =  $5 \times 10 = 50 \text{ m}^2$

The area of the land is greater.

(b) The diameter length =  $88 \div \frac{22}{7} = 28 \text{ cm}$ .

5 (a)

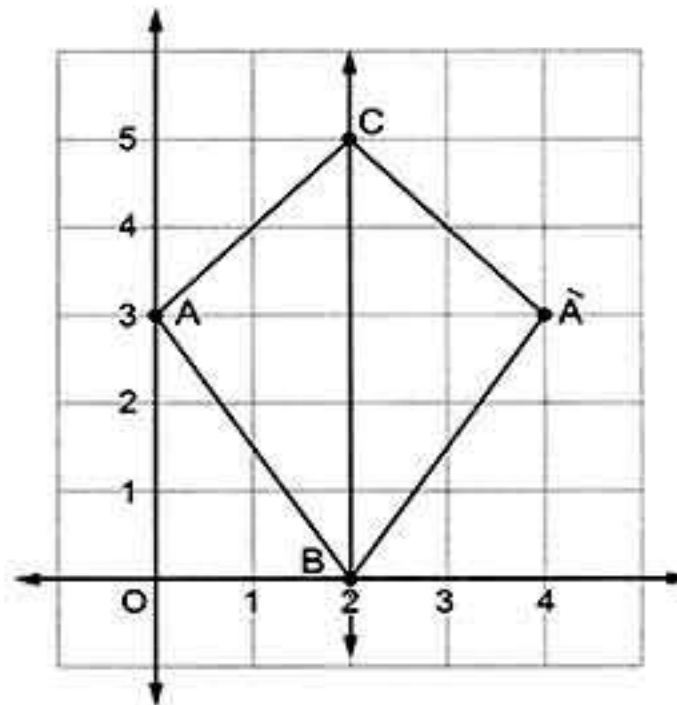



Answers of final examinations

(b) (1) 11 students.

(2)

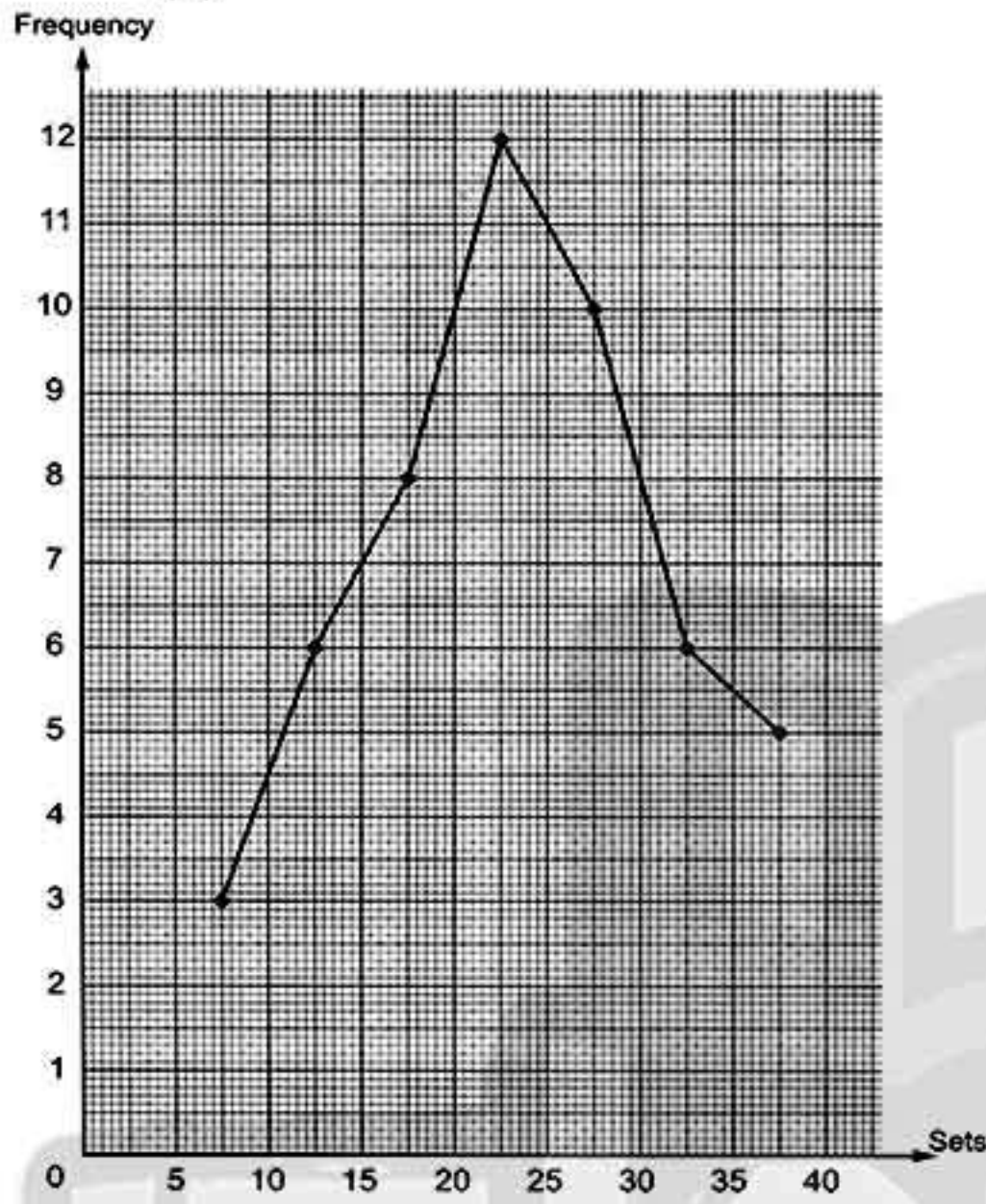

Model 16



- (a) < (b)  $x + 5$  (c) 2 (d)  $\subset$
- (a) {1, 2, 3, 4} (b) 5 (c) 96 (d) translation
- (a) The length of  $\overline{BC} = 6.5 - 2 = 4.5$  cm.  
The area of the triangle ABC =  $\frac{1}{2} \times 4.5 \times 3.2 = 7.2$  cm<sup>2</sup>.  
(b) The area of the rhombus =  $\frac{1}{2} \times 7 \times 9 = 31.5$  cm<sup>2</sup>.  
The side length of the rhombus =  $31.5 + 5 = 6.3$  cm.
- (a)  $48 + 637 + 52 + 363 = 48 + 52 + 637 + 363 = (48 + 52) + (637 + 363) = 100 + 1000 = 1100$   
(b)  $\frac{1}{3}x - 1 = 3 \Rightarrow \frac{1}{3}x = 3 + 1 \Rightarrow \frac{1}{3}x = 4 \Rightarrow x = 4 + \frac{1}{3} \Rightarrow x = 12$

5 (a)

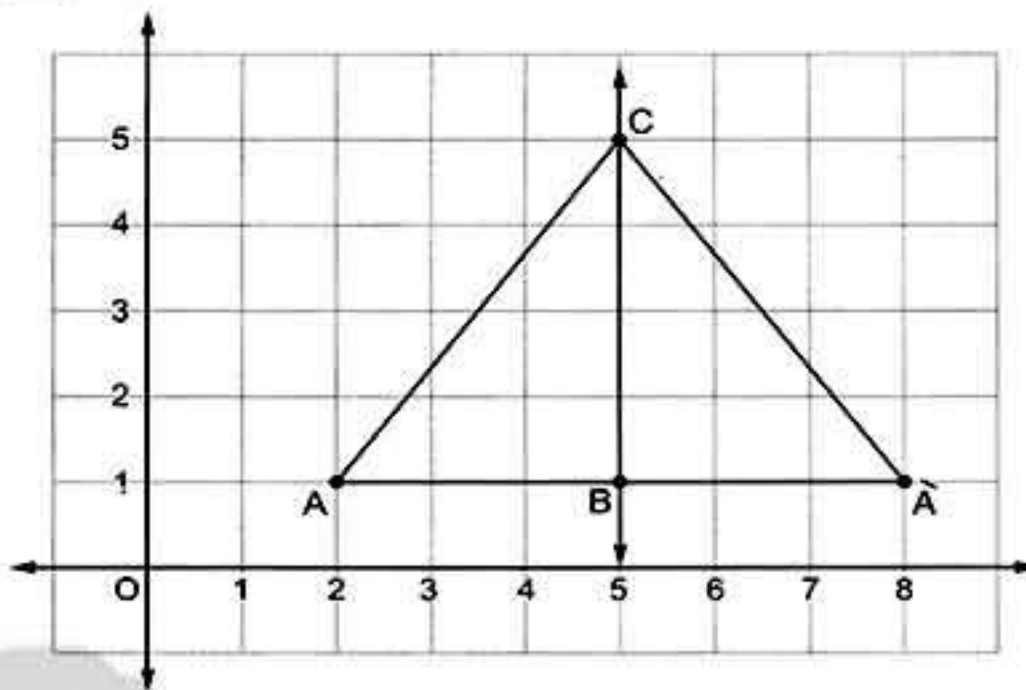

(b) (1) 16 cities.

(2) Frequency

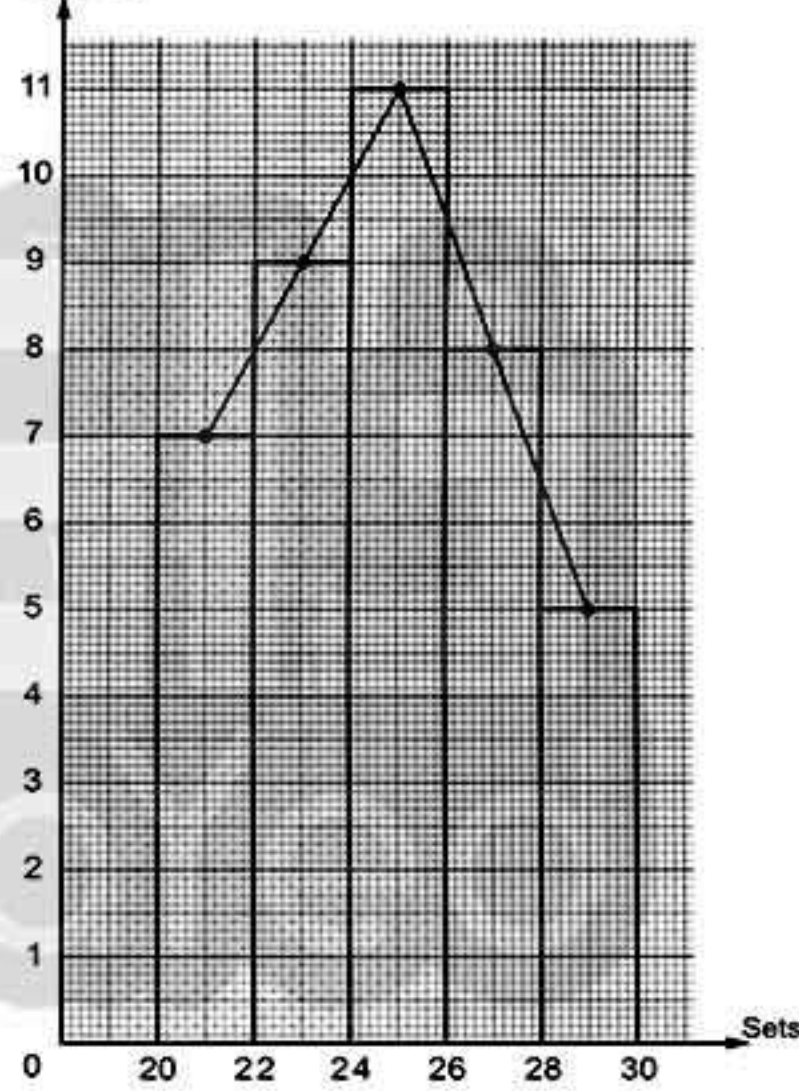

Model 17



- (a) even (b) zero (c)  $2x - 3$  (d) 25
- (a) 9 (b) 4, 3 (c) 40 (d)  $(x + y) \times 2$
- (a)  $x = \{2, 3, 4, 5, 6\}$   
  
(b)  $2x + 5 = 17 \Rightarrow 2x = 17 - 5 \Rightarrow 2x = 12 \Rightarrow x = 12 \div 2 \Rightarrow x = 6$





## Answers of Final examinations

- 4 (a) The perimeter =  $2 \times 7 \times \frac{22}{7} = 44$  cm.  
 (b) The area of the parallelogram =  $34.75 \times 28.17 = 978.9075 \approx 978.91$  cm<sup>2</sup>.

- 5 (a) (1)  $\vec{EF}$  (2)  $\vec{DF}$  (3)  $\vec{BF}$  (4)  $\vec{BF}$

(b) Food =  $\frac{1000}{2000} = \frac{1}{2}$   
 Clothes =  $\frac{500}{2000} = \frac{1}{4}$   
 Rent =  $\frac{250}{2000} = \frac{1}{8}$   
 Other spending =  $\frac{250}{2000} = \frac{1}{8}$

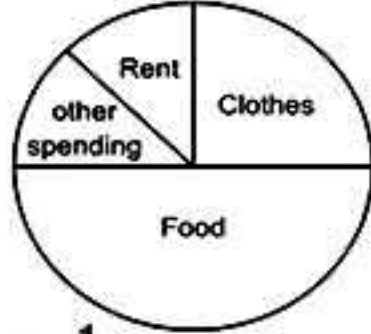

## Model 18



- 1 (a)  $\in$  (b) 9 (c) 3 (d) 0

- 2 (a) 10 (b) 34 (c) 4 (d) 48

- 3 (a) The corresponding height to the base  $\overline{AE}$  in the triangle  $ABE = \frac{60 \times 2}{12} = 10$  cm.  
 The area of the parallelogram ABCD =  $10 \times 24 = 240$  cm<sup>2</sup>.  
 (b) The length of  $\overline{AB} = 240 + 15 = 16$  cm.  
 (c) The perimeter of the parallelogram ABCD =  $(16 + 24) \times 2 = 80$  cm.

- 4 (a) (1)  $(64 + 135 + 36 + 65) \times 17 = (64 + 36 + 135 + 65) \times 17 = ((64 + 36) + (135 + 65)) \times 17 = (100 + 200) \times 17 = 300 \times 17 = 5100$   
 (2)  $84(25 \times 4 + 125 \times 8) = 84(100 + 1000) = 84 \times 1100 = 92400$

(b)  $3x + 8 = 29$        $3x = 29 - 8$   
 $3x = 21$                $x = 21 \div 3$        $x = 7$

- 5 (a)

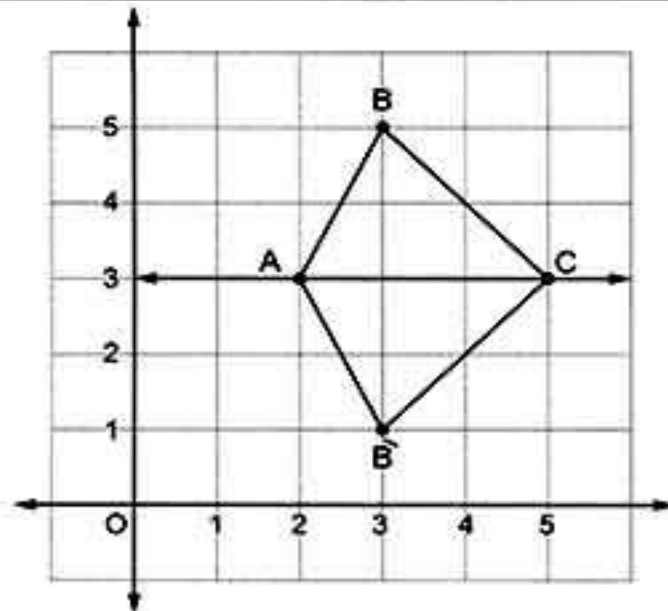

- (b)

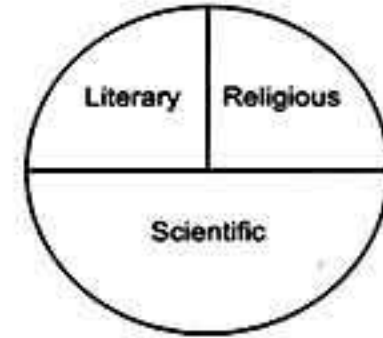

The number of religious books =  $\frac{1}{4} \times 800 = 200$  books.

The number of literary books =  $\frac{1}{4} \times 800 = 200$  books.

The number of scientific books =  $\frac{1}{2} \times 800 = 400$  books.

## Model 19



- 1 (a)  $\subset$  (b) 36  
 (c)  $P + 4$  (d) reflection

- 2 (a) 0 (b) odd (c) 2, 8 (d) 6

- 3 (a) The area of the rhombus =  $\frac{1}{2} \times 12 \times 16 = 96$  cm<sup>2</sup>.  
 The side length of the rhombus =  $\frac{96}{9.6} = 10$  cm.  
 (b) (1)  $25 \times 38 \times 4 = 25 \times 4 \times 38 = (25 \times 4) \times 38 = 100 \times 38 = 3800$   
 (2)  $44 + 66 + 56 + 34 = 44 + 56 + 66 + 34 = (44 + 56) + (66 + 34) = 100 + 100 = 200$

- 4 (a)  $14 - 3x = 8$   
 (b) The perimeter =  $(35 \times \frac{22}{7}) + 70 = 180$  cm.

- 5 (a)

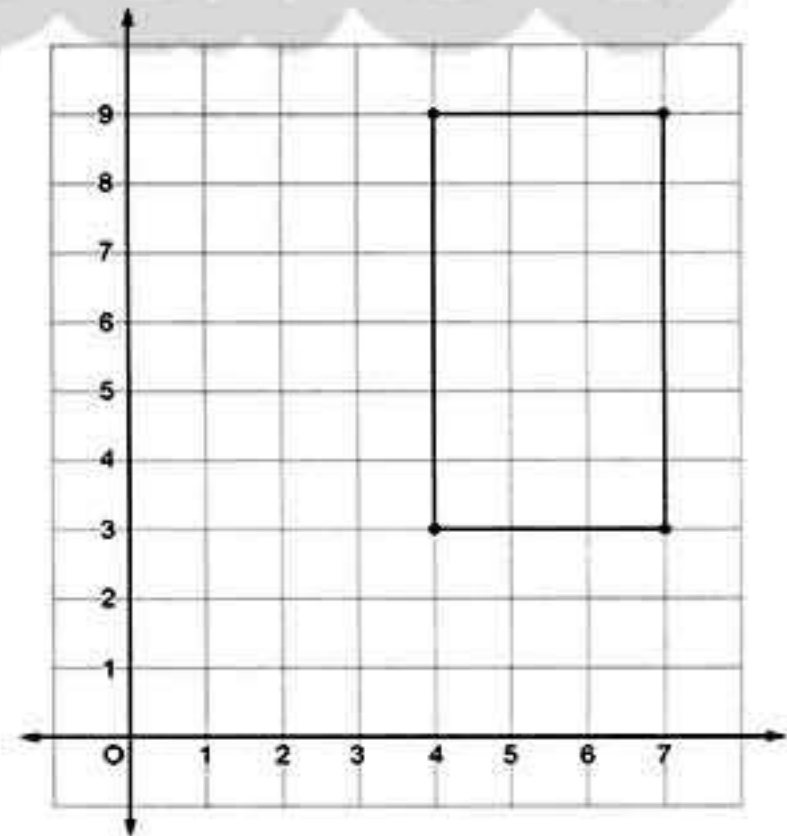

The figure is a rectangle.



Answers of final examinations

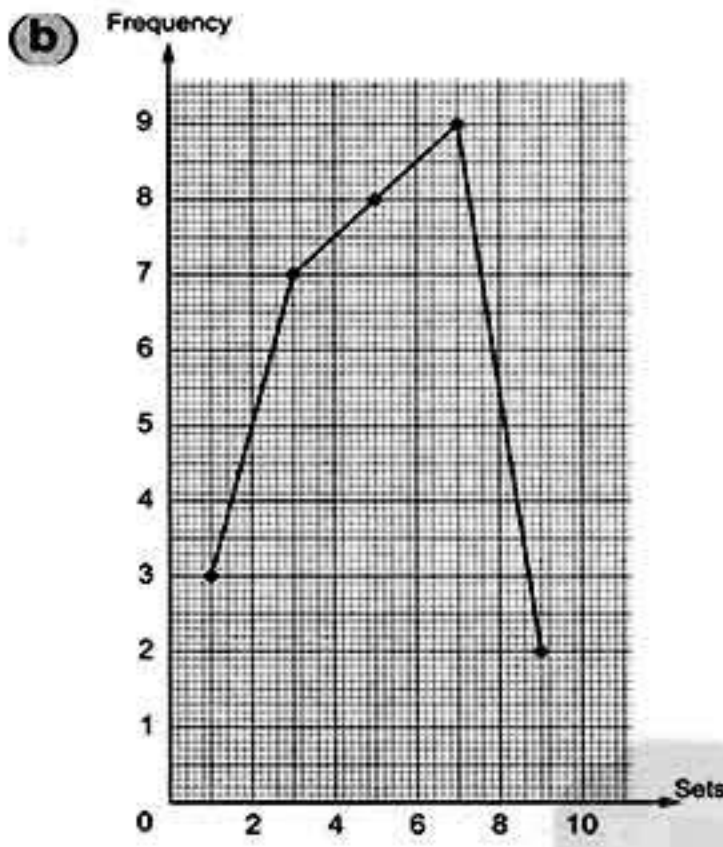

Model 20



- 1 (a) 4 (b) 2 (c)  $7x - 3$  (d) 25
- 2 (a) 20 (b) {2, 3, 4, 5, 6} (c) 0 (d) reflection
- 3 (a)  $38 + 47 + 62 + 53 = 38 + 62 + 47 + 53 = (38 + 62) + (47 + 53) = 100 + 100 = 200$   
 (b) The area of the triangle =  $\frac{1}{2} \times 18 \times 12 = 108 \text{ cm}^2$   
 The area of the rhombus =  $\frac{1}{2} \times 24 \times 8 = 96 \text{ cm}^2$   
 The area of the triangle is greater.
- 4 (a) The radius length =  $\frac{88}{2 \times \frac{22}{7}} = 14 \text{ cm}$ .  
 (b)  $3x + 5 = 26$        $3x = 26 - 5$   
 $3x = 21$                $x = 21 \div 3$        $x = 7$

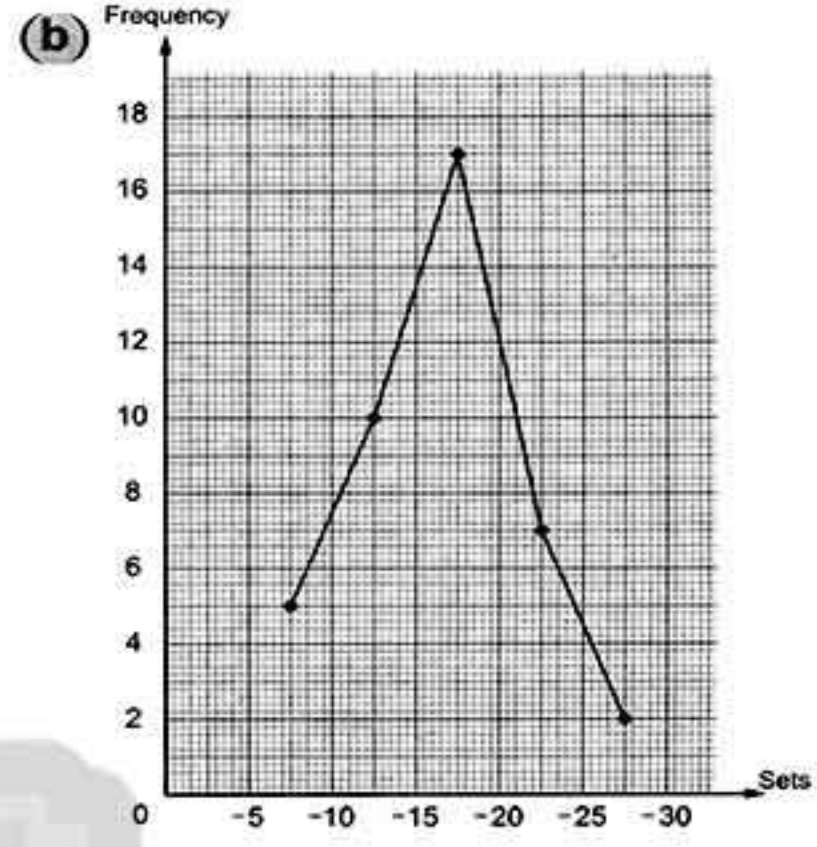
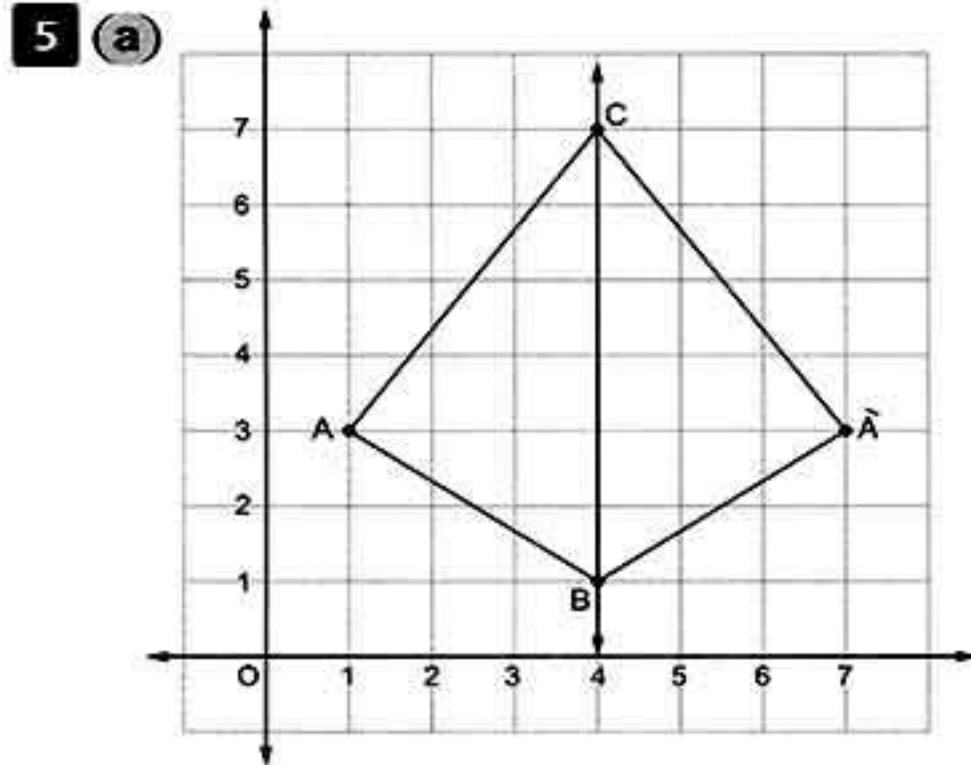

Model 21



- 1 (a)  $\neq$  (b) 0 (c) 2 (d) 10
- 2 (a)  $2x + 3$  (b) 4, 6 (c) 24 (d) (4, 7)
- 3 (a) The distance around the figure =  $(14 \times \frac{22}{7}) + 28 + 28 = 100 \text{ m}$ .  
 (b)  $25 \times 781 \times 4 = 25 \times 4 \times 781 = (25 \times 4) \times 781 = 100 \times 781 = 78\ 100$
- 4 (a) (1)  $k - 72 = 72$        $k = 72 + 72$        $k = 144$   
 (2)  $6n = 48$                $n = 48 \div 6$        $n = 8$   
 (b) (1) The area of the parallelogram ABCD =  $12 \times 10 = 120 \text{ cm}^2$   
 (2) The length of  $\overline{BC} = 120 \div 8 = 15 \text{ cm}$ .
- 5 (a)

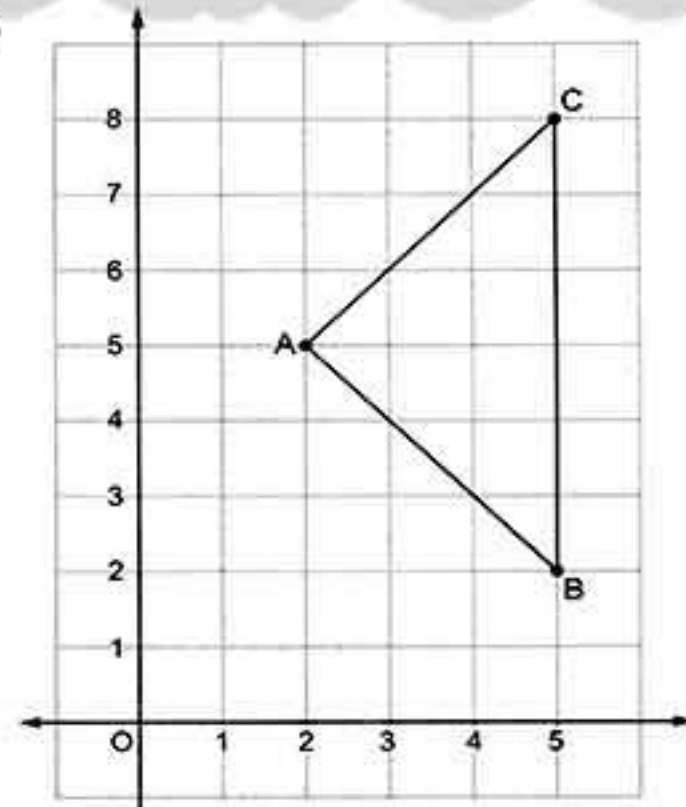

The length of  $\overline{BC} = 6$  units.





Answers of Final examinations

(b) (1) The value of  $A = 40 - (9 + 12 + 5 + 6) = 8$

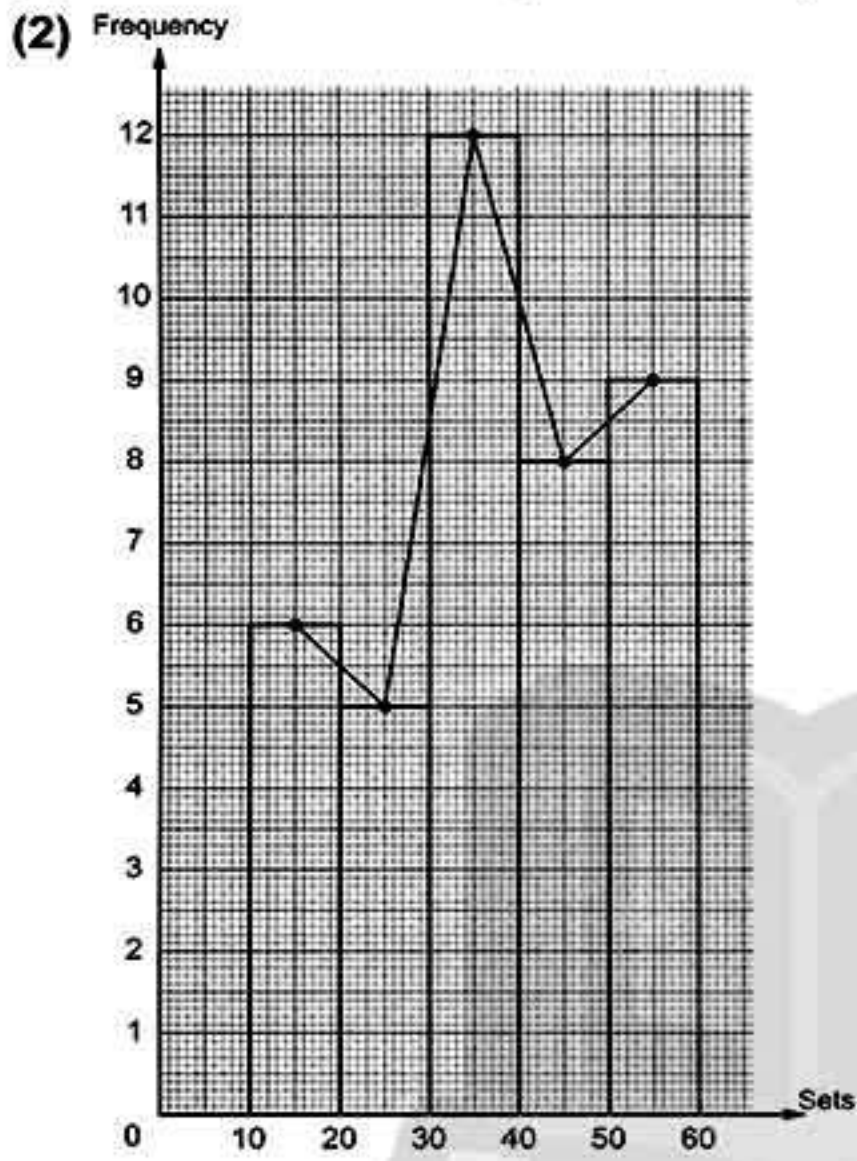

Model 22



- 1 (a)  $\notin$  (b) even  
(c)  $2y - 4$  (d) translation

- 2 (a) 2 (b) odd (c) 66 (d) 3 l

- 3 (a) (1)  $8 \times 731 \times 125 = 8 \times 125 \times 731$   
 $= (8 \times 125) \times 731$   
 $= 1000 \times 731 = 731\ 000$

- (2)  $28 + 59 + 72 = 28 + 72 + 59$   
 $= (28 + 72) + 59$   
 $= 100 + 59 = 159$

- (b) (1)  $x + 9$  (2)  $x - 8$

4

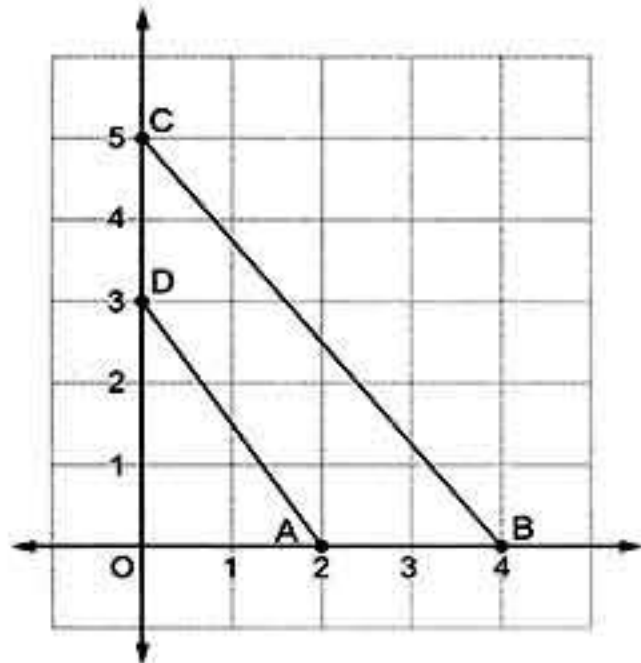

The area of the triangle OBC =  $\frac{1}{2} \times 4 \times 5$   
 $= 10$  square units.  
 The area of the triangle OAD =  $\frac{1}{2} \times 2 \times 3$   
 $= 3$  square units.  
 The area of the figure ABCD =  $10 - 3$   
 $= 7$  square units.

- 5 (a)  $72 = \frac{1}{2} \times d \times d$   
 $144 = d \times d$   
 $12 \times 12 = d \times d$   
 $d = 12$

The length of the diagonal = 12 cm.

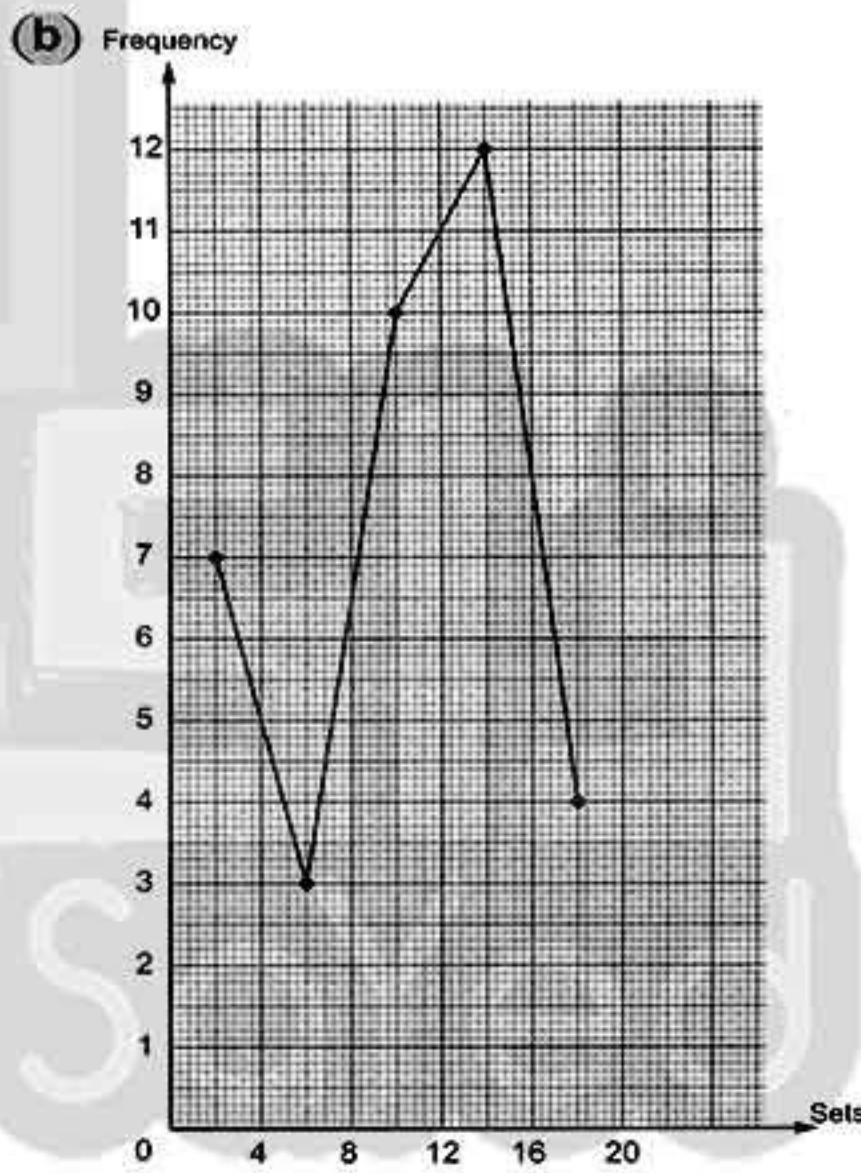

Model 23



- 1 (a) C (b) even (c) 2 (d) {2, 3}

- 2 (a) 1 (b)  $20 - x$  (c) 4  
(d) the product of the lengths of its two diagonals

- 3 (a) The area of the triangle =  $\frac{1}{2} \times 12 \times 8$   
 $= 48 \text{ cm}^2$   
 The area of the parallelogram =  $5 \times 10$   
 $= 50 \text{ cm}^2$   
 The area of the parallelogram is greater.



## Answers of final examinations

(b) (1)  $x + 3 = 17$     $x = 17 - 3$     $x = 14$

(2)  $2x + 7 = 23$     $2x = 23 - 7$

$2x = 16$     $x = 16 \div 2$     $x = 8$

4 (a) (1)  $156 + 871 + 344 + 129$   
 $= 156 + 344 + 871 + 129$   
 $= (156 + 344) + (871 + 129)$   
 $= 500 + 1000 = 1500$

(2)  $27(25 \times 4 + 125 \times 8)$   
 $= 27(100 + 1000)$   
 $= 27 \times 100 + 27 \times 1000$   
 $= 2700 + 27000 = 29700$

(b) The circumference of the base  $= 7 \times \frac{22}{7}$   
 $= 22 \text{ cm.}$

5 (a)

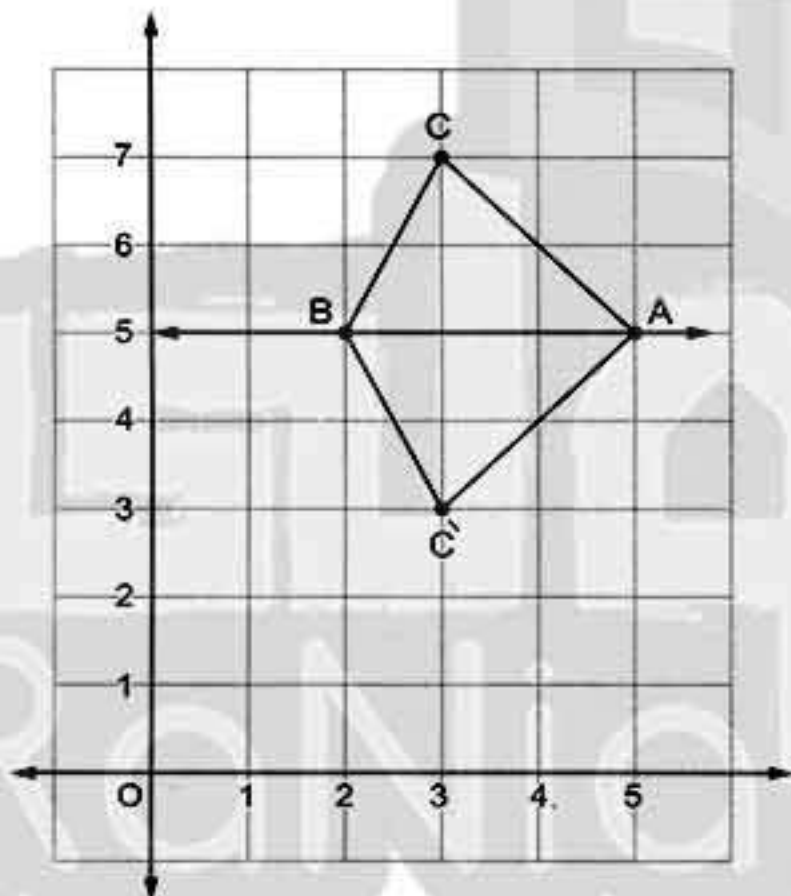

(b) The number of female candidates  
 $= \frac{3}{4} \times 220 = 165$

Model 24



1 (a) <   (b) reflection   (c) 0   (d) 8

2 (a) 9   (b)  $2z - 8$    (c)  $\pi$    (d) 13, 21

3 (a) The area of the parallelogram ABCD  
 $= 18 \times 10 = 180 \text{ cm}^2$   
The length of  $\overline{DE} = \frac{180}{12} = 15 \text{ cm.}$

(b) The distance  $= (7 \times \frac{22}{7}) + 14 = 36 \text{ cm.}$

4 (a) (1)  $38 + 47 + 82 + 53 = 38 + 62 + 47 + 53$   
 $= (38 + 62) + (47 + 53)$   
 $= 100 + 100 = 200$

(2)  $8 \times 37 \times 125 = 8 \times 125 \times 37$   
 $= (8 \times 125) \times 37$   
 $= 1000 \times 37 = 37000$

(b) (1)  $x + 17 = 28$    (2)  $y - 9 = 23$

5 (a)

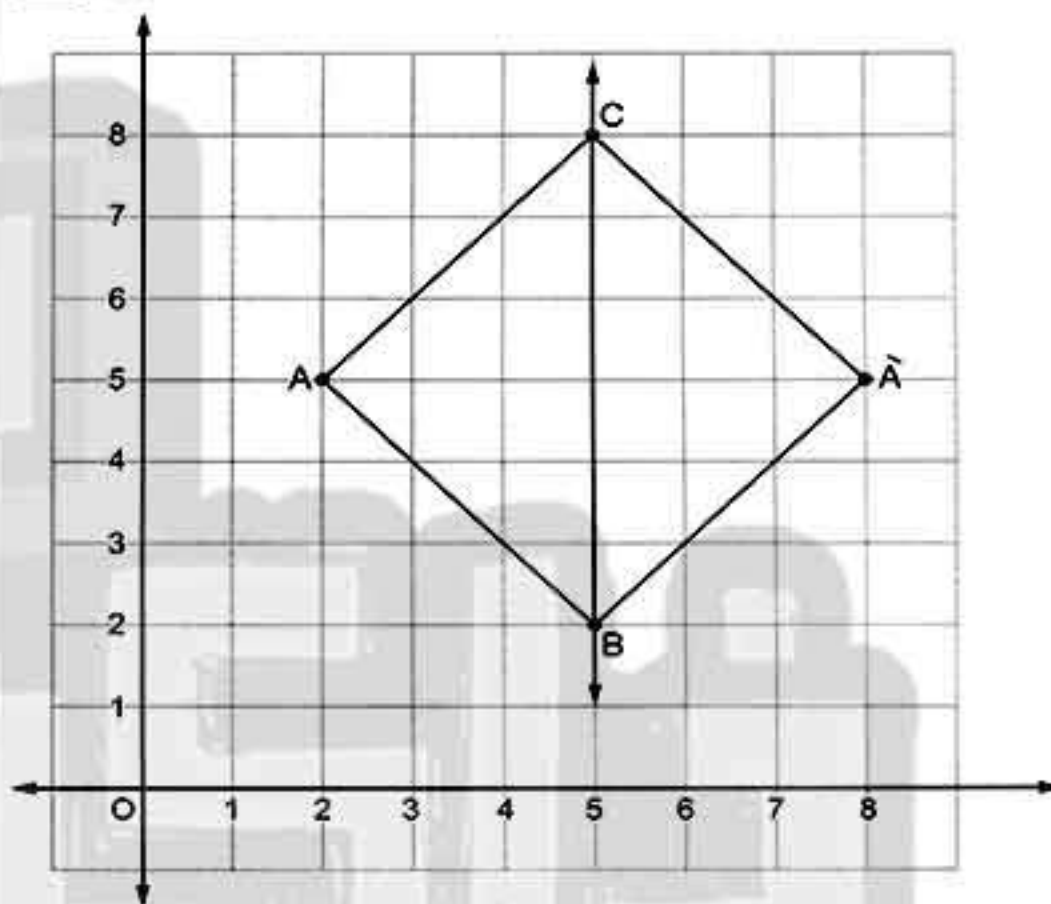

(b) Frequency

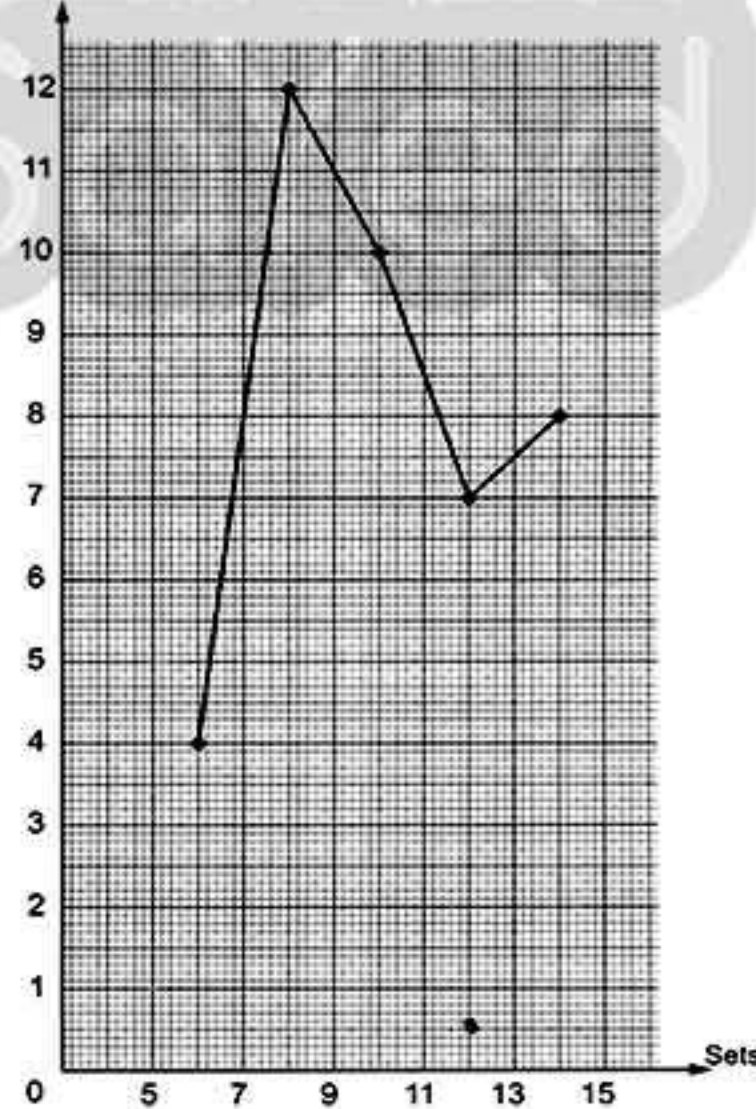





## Answers of Final examinations

## Model 25



1 (a)  $\subset$  (b) 1 (c)  $\in$  (d) 1

2 (a) (3, 5) (b) 7 (c)  $2x - 8$  (d) 8

3 (a)  $4 \times 72 \times 25 = 4 \times 25 \times 72$   
 $= (4 \times 25) \times 72$   
 $= 100 \times 72 = 7\ 200$

(b)

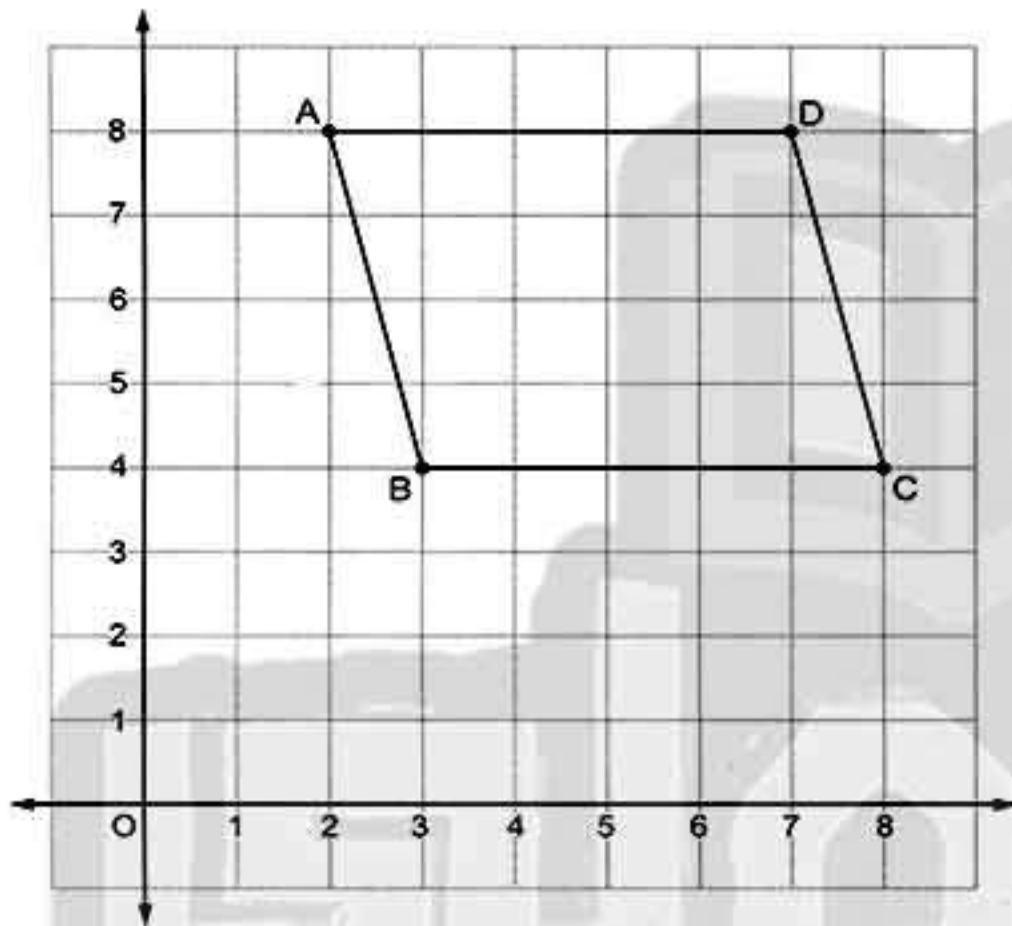

Parallelogram.

4 The distance =  $(7 \times \frac{22}{7}) + 21 + 21 = 64$  m.

5 (a)  $\frac{1}{3}x - 2 = 8$      $\frac{1}{3}x = 8 + 2$   
 $\frac{1}{3}x = 10$      $x = 10 \div \frac{1}{3}$      $x = 30$

(b) Football =  $\frac{20}{40} = \frac{1}{2}$

Basketball =  $\frac{10}{40} = \frac{1}{4}$

volleyball =  $\frac{10}{40} = \frac{1}{4}$

